

Compressor Technical Data

Model **GL50AA** Code **406090330116**

LBP

General Data

Refrigerant:	R134a
Application:	LBP
Evaporating Temperature Range:	-30°C to -10°C
Voltage/Frequency:	220-240V 50Hz 1~
Compressor Cooling:	Static
Expansion Device:	Capillary Tube
Packaging Quantity:	Multi - 96:120 pcs
Approvals:	CE-VDE-GOST



Mechanical Data

Oil Charge:	270 cm ³
Oil Type Configuration:	ester
Oil Type Viscosity:	19 cSt
Weight:	8.9 kg

Electrical Data

Motor Type:	RSIR / RSCR*
Voltage working range at 50 Hz:	187-264V
Maximum Motor Temperature:	130°C
Locked Rotor Current:	8.6 / 3.7 A
Start Winding Resistance:	25.10 Ω at 25°C
Run Winding Resistance:	19.70 Ω at 25°C
Phase :	1 ph

External Characteristics

Internal Diameter	(mm)
Suction Connector	6.5
Discharge Connector	4.9
Process Connector	6.5
Material	Copper

Electrical Components

Component Type	
Starting Device:	PTC 14 Ω
Motor Protection:	T0462/xx

Circuit Diagram for Mod.90 Terminal Board

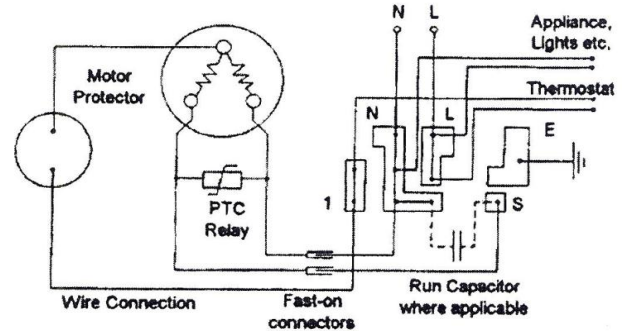

Circuit Diagram for U.H. Terminal Board

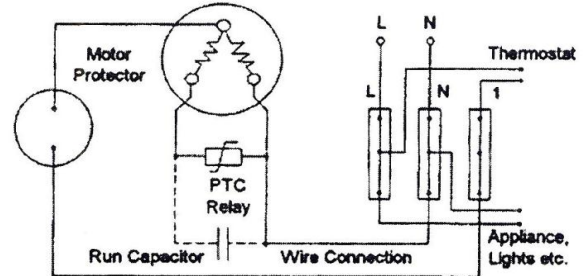

Recommended Transport Positions when fitted into appliances

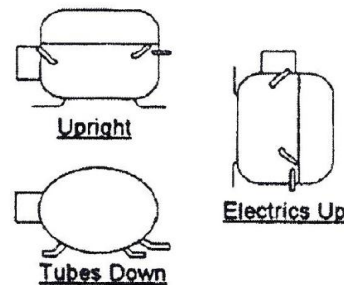

MCMC compressors reserves the right to change the data without prior notice

10th of Ramadan City - (Cairo) Egypt
Industrial Zone A-2
P.o Box : 1001 (10th of Ramadan)
Tel. : 0554 - 413322 (10 lines)
Fax. : 0554 - 413161 - 413029
Web site : <http://www.zmcegypt.com>

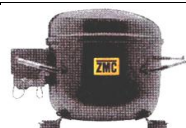

العاشر من رمضان
المنطقة الصناعية أ - 2
ص.ب : 1001 العاشر من رمضان
تليفون : 0554-413322 (10 خطوط)
فاكس : 0554)413029 - 413161

PERFORMANCE CURVE DATA :

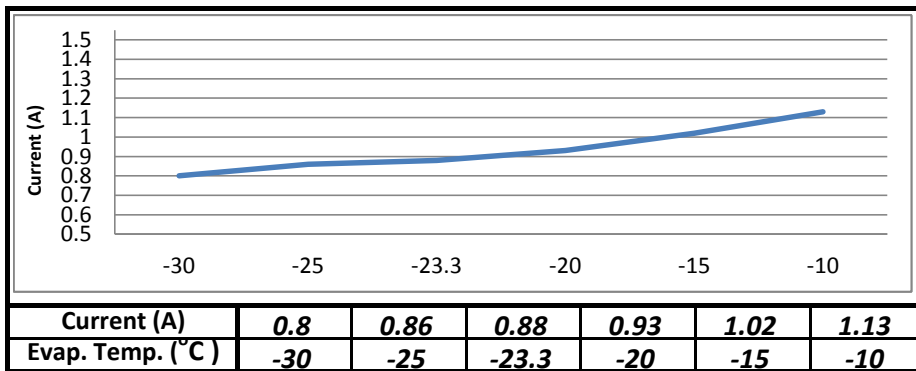
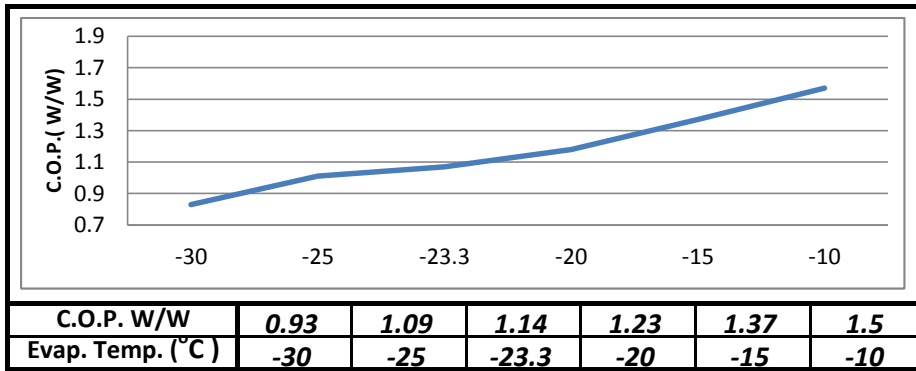
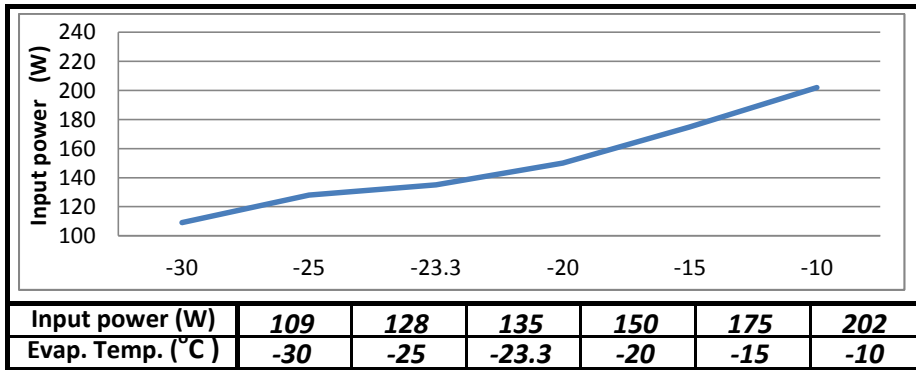
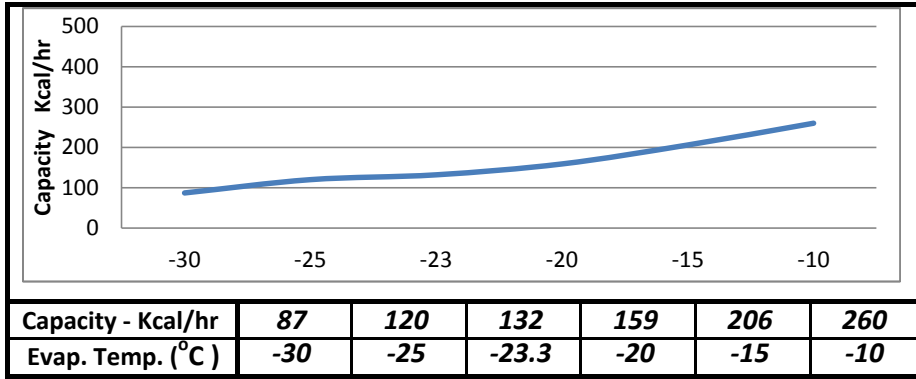

Test Condition: Ashrae, Static, Return Gas 32°C Subcooling OK, Evaporating: 23.3°C, Condensing: 55°C, Ambient: 32°C

10th of Ramadan City - (Cairo) Egypt
 Industrial Zone A-2
 P.o Box : 1001 (10th of Ramadan)
 Tel. : 0554 - 413322 (10 lines)
 Fax. : 0554 - 413161 - 413029
 Web site : <http://www.zmcegypt.com>



العاشر من رمضان
 المنطقة الصناعية أ - 2
 ص.ب : 1001 العاشر من رمضان
 تليفون : 0554- 413322 (10 خطوط)
 فاكس : 0554)413029 - 413161

GM, GN and GL models

HL and HP models

Standard dimensions for mounting hole centres: 170x70 mm

Special feet

Models	Distance between holes	Holes diameter
GM/GN/HL/HP/GP	165 x 101.6	4 x 19
	170 x 70	6 x 165

Material	Tube internal diameter "GM", "GN", "GL", "HL"			"HP" and "GP"		
	Suction	Service	Discharge	Suction	Service	Discharge
Copper steel / copper	6.1	6.1	4.9	6.1	6.1	4.9
Copper	6.1	6.1	5.1	6.5	6.5	4.9
Copper	6.5	6.5	4.9	8.1	8.1	6.5
Copper	8.1	8.1	6.5			

Mounting accessories

Standard

Standard

10th of Ramadan City - (Cairo) Egypt
 Industrial Zone A-2
 P.o Box : 1001 (10th of Ramadan)
 Tel. : 0554 - 413322 (10 lines)
 Fax. : 0554 - 413161 - 413029
 Web site : <http://www.zmcegypt.com>

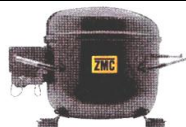

العاشر من رمضان
 المنطقة الصناعية أ - 2
 ص.ب : 1001 العاشر من رمضان
 تليفون : 0554- 413322 (10 خطوط)
 فاكس : 413029 - 413161 (0554)

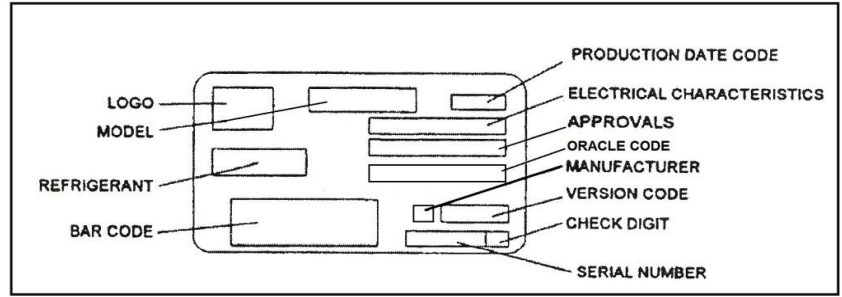
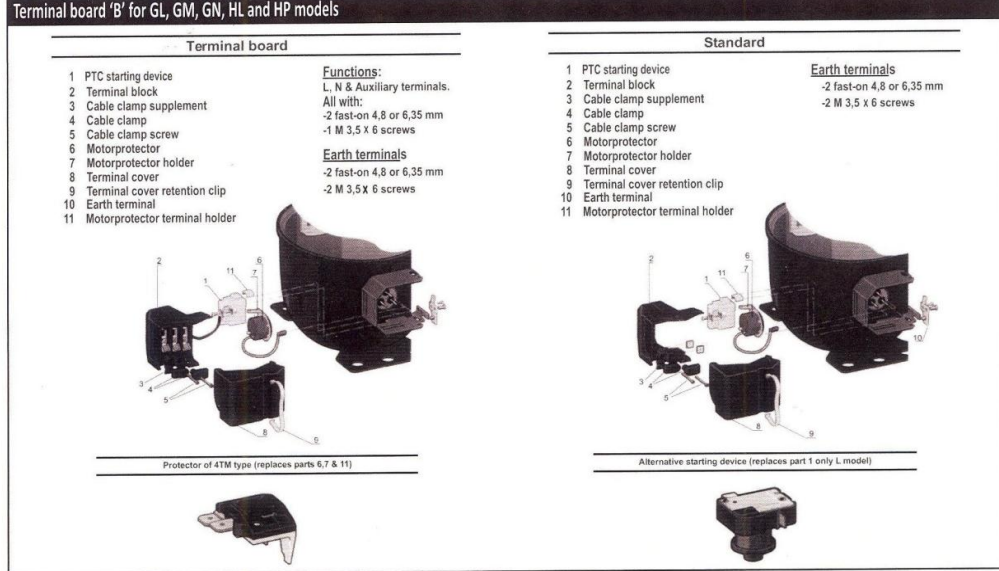
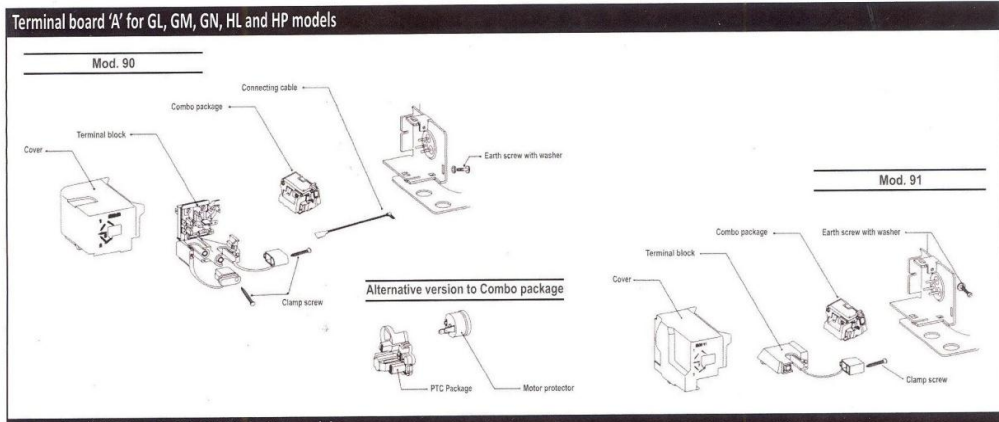

10th of Ramadan City - (Cairo) Egypt
Industrial Zone A-2
P.o Box : 1001 (10th of Ramadan)
Tel. : 0554 - 413322 (10 lines)
Fax. : 0554 - 413161 - 413029
Web site : <http://www.zmcegypt.com>



العاشر من رمضان
المنطقة الصناعية أ - 2
ص.ب : 1001 العاشر من رمضان
تليفون : 0554- 413322 (10 خطوط)
فاكس : 413161 - 413029 (0554)