

ZEL

GENERAL CATALOGUE

COMPRESSORS

R600a - R290 - R134a

All solutions inside.





扎努西电气机械天津压缩机有限公司(ZEL)前身为天津海河电冰箱压缩机公司,早在上世纪60年代,ZEL就开始借鉴国外技术研制、生产冰箱用压缩机;1987年,公司引进欧洲最先进的扎努西压缩机制造技术和生产线,以许可证的方式开始生产ZEL品牌的压缩机;1993年,与意大利扎努西建立了国内压缩机行业的第一家合资企业,并最早通过国际知名认证机构的质量体系认证,率先完成CFCs替代。多年来ZEL的产品一直得到国内外知名客户的一致好评。2013年,在制冷行业全球性优化重组的背景下,通过股权更迭,航天振邦精密机械有限公司成为了ZEL新的控股股东,带来了雄厚的资金支持和航天军工领域以及压缩机行业生产设备和零部件加工方面的丰富经验。

ZEL专业从事全封闭活塞式压缩机产品的研发和制造,产品可广泛应用于冰箱、冷柜及各种小型商用制冷设备。ZEL的产品范围广、种类齐全,覆盖了从R134a到R600a,从低背压(LBP)到中高背压(HMBP),从定频到变频的范围,并能满足全球不同区域电压的需求。产品种类包括了自意大利引进的Tau和独立研发的Lambda,Zeta小型高效制冷压缩机共三大平台200多个型号规格。

随着新股东的进入,ZEL在新产品开发和技术创新方面将继续保持活力,并且进一步完善质量管理体系,提高产品品质和顾客满意度,ZEL将以全新的面貌积极参与市场竞争,加快推出更多优质、高效的压缩机产品,谱写扎努西品牌新的辉煌。

We lead the refrigeration world.

Zanussi Elettromeccanica Tianjin Compressor Co., Ltd (ZEL) was the pioneer in hermetic compressor manufacturing in China. It started to produce household refrigerating compressor in 1960s, as licensee of Zanussi Elettromeccanica - Italy in 1987, and to become the first joint-venture company in domestic compressor industry in 1993. The strategic partnership with ACC has provided ZELT with state of art technologies, products and manufacturing systems, which were for many years bench-mark for all other Chinese producers. For many years ZEL was recognized as reliable producer of high quality products and as such has been awarded by many domestic and overseas customers. In 2013, Beijing Zhenbang Aerospace Precision Machinery Co., Ltd has become ZEL's main shareholder by acquiring equity share from ACC Italy. Zhenbang's technological leadership in the areas of precision machinery, aerospace, military and compressor products together with solid financial background have enabled strong ZEL's restructuring program with significant capital expenditures in quality improvement, capacity increasing and launching of new high performance products.

ZEL develops and manufactures refrigerating hermetic compressors. Three platforms include Tau licensed from Italy and independent development of compact, high efficiency Lambda and Zeta series. With more than 200 models are covering LBP and HMBP applications for household refrigerators, chest freezers and small size commercial applications. Wide variety of voltage ranges is available with constant and variable speed design for R600a and R134A refrigerant.

Successful restructuring process will make ZEL appear in the market competition with brand-new faces, and compose its new refulgent by accelerating launch more good quality and high performance products.

mini compressors a major innovation

小型、高效、绿色环保压缩机

Lambda

R600a, ASHRAE LBP工况条件下,
制冷量范围70W~200W,
COP最高达1.98W/W

R134a, AHAM工况条件下,
制冷量范围145W~230W,
COP最高达2.08W/W

Zeta

脱胎于**Lambda**平台的突破性产品,
目标是提供更具性价比的
高效压缩机平台

R600a, ASHRAE LBP工况条件下,
制冷量范围80W~170W,
铝电机版本COP最高达1.98W/W

Micro

综合**Lambda**和**Zeta**平台特点,
体积更小,
高性价比的中低效压缩机平台

R600a, ASHRAE LBP工况条件下,
制冷量50W~120W,
COP最高达到1.70W/W

Performance

Lambda and Zeta represent an ideal solution from small to medium refrigerators. Maximum COP of 2.00W/W* of Lambda while 1.98W/W* of Zeta with aluminum motor, combines top efficiency with compact dimensions in order to optimize performance in our customer's appliance.

*220-240V/50Hz, R600a, ASHRAE LBP conditions

Environment

ZEL has a consolidated tradition in environmentally friendly solutions. It has historically been the first compressor manufacturer to shift to non-CFC coolants starting in 1992, leading the transition to ozone safe technologies and also in choosing the R600a refrigerant. Lambda and Zeta are a further step towards innovation and energy-saving.

A global solution

A perfect complement to the Kappa Dual family, Lambda has been developed both in R600a and R134a version. ZEL strives to provide customers with competitive solutions suitable for all markets, to guarantee both local and international manufacturers with state-of-the-art compressors.

Compactness

Compared to ZEL's other platforms with similar performance characteristics, Lambda and Zeta represent a compact alternative with a 7% height reduction which allows to our customers to benefit with potential cabinet net volume increase.



Nomenclature 命名规则

Lambda/Zeta/Micro

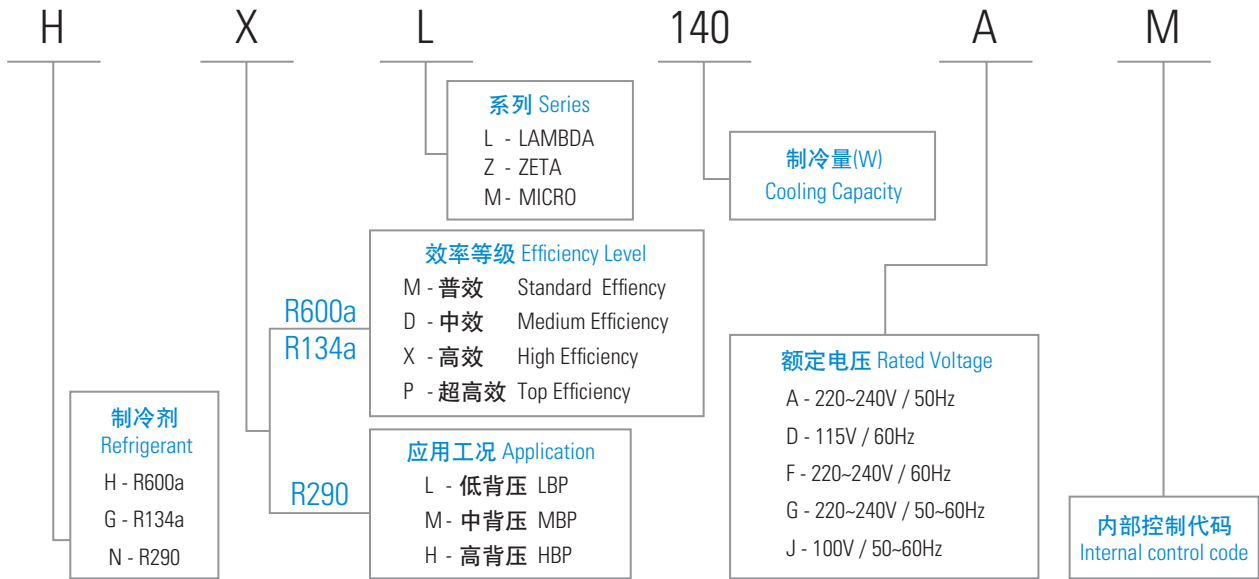

Tau

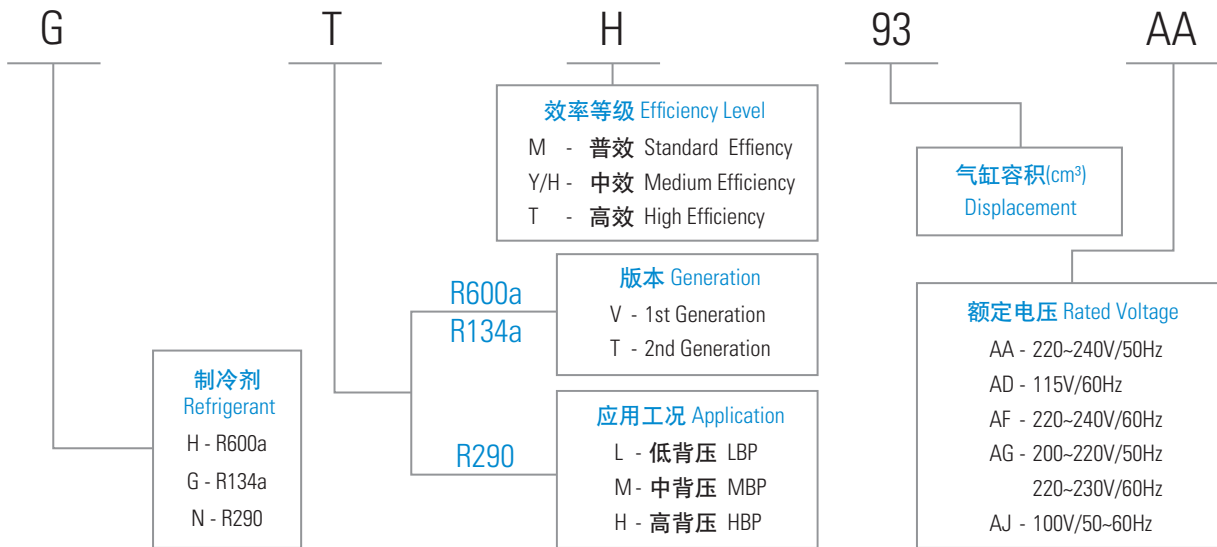

VSC

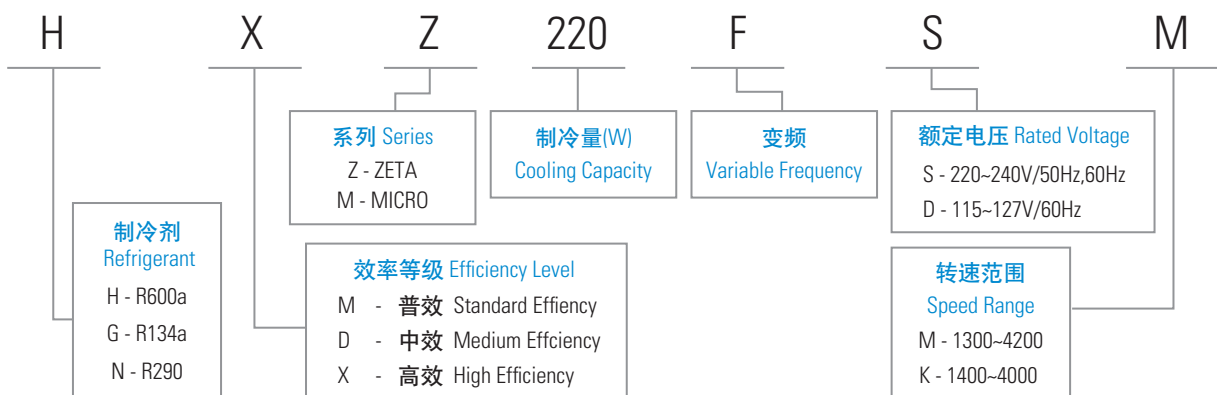

型号	电机	排气量	电机类型	频率	制冷量		输入功率	性能系数	启动电容	运行电容	高度	重量	认证
Model	Motor	Displ.	Motor Type	Freq.	Cooling Capacity	Cooling Capacity	Input Power	COP	Start Capacitor	Run Capacitor	Height	Net Weight	Certification
		cm ³		hz	w	kcal/h	w	w/w	μF	μF	mm	kg	

220-240V/50Hz

普效系列 Standard Efficiency Range

HML140A	Al	8.0	RSCR	50	140	120	90	1.56	-	3	152	6.3	CCC/VDE
HML140A I	Al	8.0	RSCR	50	140	120	88	1.60	-	3	161	6.9	-
HML155A	Al	8.6	RSCR	50	155	133	107	1.45	-	3	161	6.9	CCC/VDE
HML155A I	Al	8.6	RSCR	50	155	133	97	1.60	-	3	161	6.9	-
HML170A	Al	9.5	RSCR	50	170	146	115	1.48	-	3	161	6.9	CCC/VDE
HML170A I	Al	9.5	RSCR	50	170	146	106	1.60	-	3	161	6.9	-
HML190A	Al	10.5	RSCR	50	190	163	131	1.45	-	3	164	7.2	-
HML200A	Al	11.4	RSCR	50	200	172	133	1.50	-	4	164	7.2	CCC/VDE

中效系列 Medium Efficiency Range

HDL100A	Al	5.7	RSCR	50	98	84	58	1.70	-	2.5	164	7.2	CCC/VDE
HDL125A	Al	7.0	RSCR	50	123	106	72	1.72	-	2.5	164	7.2	CCC/VDE
HDL140A	Al	8.0	RSCR	50	140	120	81	1.72	-	2.5	164	7.2	CCC/VDE
HDL155A	Al	8.6	RSCR	50	155	133	91	1.70	-	4	164	7.2	CCC
HDL170A	Al	9.5	RSCR	50	170	146	100	1.70	-	4	164	7.2	CCC
HDL190A	Cu/Al	10.5	RSCR	50	190	163	114	1.66	-	4	164	7.2	-
HDL200A	Cu/Al	11.4	RSCR	50	200	172	120	1.66	-	4	164	7.2	CCC

高效系列 High Efficiency Range

HXL100A**	Cu	5.7	RSCR	50	98	84	52	1.88	-	2	161	7.3	CCC/VDE
HXL125A**	Cu	7.0	RSCR	50	125	108	65	1.91	-	2	161	7.3	CCC/VDE
HXL140A**	Cu	8.0	RSCR	50	140	120	73	1.91	-	2	161	7.3	CCC/VDE
HXL155A**	Cu	8.5	RSCR	50	155	133	82	1.88	-	2	161	7.3	CCC/VDE
HXL170A**	Cu	9.3	RSCR	50	175	151	93	1.88	-	2	164	7.3	CCC/VDE
HXL190A	Cu	10.5	RSCR	50	190	168	103	1.85	-	3	164	7.3	CCC
HXL200A	Cu	11.4	RSCR	50	200	172	111	1.80	-	3	164	7.3	-

超高效系列 Top Efficiency Range

HPL100A	Cu	5.7	CSCR	50	100	86	51	1.96	15	2	161	7.3	CCC/VDE
HPL125A	Cu	7.0	CSCR	50	125	108	64	1.96	15	2	161	7.3	CCC/VDE
HPL140A	Cu	8.0	CSCR	50	140	120	71	1.98	15	2	161	7.3	CCC/VDE

160-260V/50Hz

普效系列 Standard Efficiency Range

HML100A T	Al	6.0	RSCR	50	103	89	71	1.45	-	2	152	6.3	-
HML125A T	Al	7.0	RSCR	50	125	112	83	1.50	-	2	152	6.3	CCC/VDE
HML140A T	Al	8.0	RSCR	50	140	120	97	1.45	-	3	161	6.3	CCC/VDE
HML155A T	Al	8.6	RSCR	50	155	133	111	1.40	-	3	161	6.9	-
HML170A T	Al	9.5	RSCR	50	170	146	113	1.50	-	3	164	7.2	CCC/VDE

中效系列 Medium Efficiency Range

HDL100A T	Al	6.0	RSCR	50	103	89	62	1.65	-	2	161	6.9	-
HDL125A T	Al	7.0	RSCR	50	125	112	76	1.65	-	2	161	6.9	CCC/VDE
HDL140A T	Al/Cu	8.0	RSCR	50	140	120	85	1.65	-	3	164	7.2	CCC/VDE
HDL155A T	Cu/Al	8.6	RSCR	50	155	133	94	1.65	-	3	164	7.2	-
HDL170A T	Cu/Al	9.5	RSCR	50	170	146	103	1.65	-	3	164	7.2	CCC/VDE

注 NOTE

冷却方式	Cooling Type
静态冷却	Static Cooling
应用条件	Application
低背压	LBP

测试工况

TEST CONDITIONS(ASHRAE)	
蒸发温度	Evaporating temperature -23.3°C
冷凝温度	Condensing temperature 54.4°C
过冷温度	Subcooling temperature 32.2°C
吸气温度	Suction temperature 32.2°C
环境温度	Ambient temperature 32.2°C

单位换算 CONVERSION

1 Watt = 3.41 Btu/h = 0.86 kcal/h

*即将发布 Release on progress

**备选型号 (优先选用ZETA平台)

型号	电机	排气量	电机类型	频率	制冷量		输入功率	性能系数	启动电容	运行电容	高度	重量	认证
Model	Motor	Displ.	Motor Type	Freq.	Cooling Capacity	Cooling Capacity	Input Power	COP	Start Capacitor	Run Capacitor	Height	Net Weight	Certification
		cm ³		hz	w	kcal/h	w	w/w	μF	μF	mm	kg	
160-260V/50Hz													
高效系列 High Efficiency Range													
HXL100A T	Cu	6.0	RSCR	50	103	89	59	1.75	-	2	164	7.3	-
HXL125A T	Cu	7.0	RSCR	50	125	112	71	1.75	-	2	164	7.3	CCC/VDE
HXL140A T	Cu	8.0	RSCR	50	140	120	80	1.75	-	3	164	7.3	CCC/VDE
HXL155A T	Cu	8.6	RSCR	50	155	133	89	1.75	-	3	164	7.3	-
HXL170A T	Cu	9.5	RSCR	50	170	146	97	1.75	-	3	164	7.3	CCC/VDE
220-240V/60Hz													
普效系列 Standard Efficiency Range													
HML125F	Al	6.3	RSCR	60	130	112	87	1.50	-	2	152	6.3	CB
HML140F	Al	7.0	RSCR	60	145	125	97	1.50	-	3	152	6.3	CB
HML160F	Al	7.5	RSCR	60	160	138	107	1.50	-	3	161	6.9	CB
HML180F	Al	8.6	RSCR	60	180	155	120	1.50	-	5	164	7.3	CB
HML190F	Al	9.2	RSCR	60	195	163	130	1.50	-	5	164	7.2	CB
中效系列 Medium Efficiency Range													
HDL125F	Al	6.3	RSCR	60	130	112	79	1.65	-	2	161	7.2	CB
HDL140F	Al	7.0	RSCR	60	145	125	90	1.62	-	3	161	7.2	CB
HDL160F	Al	7.5	RSCR	60	160	138	98	1.64	-	3	161	7.2	CB
HDL180F	Cu/Al	8.6	RSCR	60	180	155	106	1.70	-	5	164	7.3	CB
HDL190F	Cu/Al	9.2	RSCR	60	195	163	112	1.70	-	5	164	7.2	CB
高效系列 High Efficiency Range													
HXL140F	Cu	7.0	RSCR	60	140	120	74	1.90	-	3	161	7.2	CB
HXL160F	Cu	7.5	RSCR	60	160	138	84	1.90	-	3	161	7.2	CB
HXL190F	Cu	9.2	RSCR	60	195	163	103	1.85	-	3	161	7.2	CB
220-240V/50-60Hz													
普效系列 Standard Efficiency Range													
HML125G*	Al	7.5	RSCR	50	130	112	87	1.50	-	2	152	6.3	-
				60	153	132	96	1.60					
HML140G	Al	8.0	RSCR	50	140	120	97	1.45	-	4	161	6.9	CCC/VDE
				60	167	144	108	1.55					
HML155G	Al	8.6	RSCR	50	155	133	107	1.45	-	4	161	6.9	-
				60	180	155	116	1.55					
HML170G*	Al	9.2	RSCR	50	165	142	114	1.45	-	4	161	6.9	-
				60	192	165	124	1.55					
中效系列 Medium Efficiency Range													
HDL140G*	Al	8.0	RSCR	50	145	125	90	1.62	-	4	164	7.2	-
				60	170	146	99	1.72					
HDL155G	Al	8.6	RSCR	50	155	133	96	1.62	-	4	164	7.2	-
				60	180	155	105	1.72					
HDL170G	Cu/Al	9.2	RSCR	50	168	144	102	1.65	-	4	164	7.2	CCC/VDE
				60	200	172	116	1.72					

注 NOTE

冷却方式 Cooling Type
 静态冷却 Static Cooling
 应用条件 Application
 低背压 LBP
 *即将发布 Release on progress

测试工况

蒸发温度 Evaporating temperature -23.3°C
 冷凝温度 Condensing temperature 54.4°C
 过冷温度 Subcooling temperature 32.2°C
 吸气温度 Suction temperature 32.2°C
 环境温度 Ambient temperature 32.2°C

TEST CONDITIONS(ASHRAE)

单位换算 CONVERSION

1 Watt = 3.41 Btu/h = 0.86 kcal/h

型号	电机	排气量	电机类型	频率	制冷量		输入功率	性能系数	启动电容	运行电容	高度	重量	认证
Model	Motor	Displ.	Motor Type	Freq.	Cooling Capacity	Cooling Capacity	Input Power	COP	Start Capacitor	Run Capacitor	Height	Net Weight	Certification
		cm ³		hz	w	kcal/h	w	w/w	μF	μF	mm	kg	
220-240V/50-60Hz													
高效系列 High Efficiency Range													
HXL155G*	Cu	8.6	RSCR	50	155	133	89	1.75	-	4	164	7.6	-
				60	180	155	97	1.85					
HXL185G	Cu	10.1	RSCR	50	185	159	106	1.75	-	4	164	7.6	CCC/VDE
				60	215	185	117	1.83					
115V/60Hz													
普效系列 Standard Efficiency Range													
HML125D	Al	6.3	RSCR	60	134	115	88	1.53	-	2	152	6.3	UL
HML140D	Al	7.0	RSCR	60	145	125	96	1.50	-	2	152	6.3	-
HML160D	Al	8.0	RSCR	60	165	142	110	1.50	-	2	161	6.9	-
HML180D	Al	8.6	RSCR	60	180	155	120	1.50	-	10	164	6.9	-
HML200D	Al	9.3	RSCR	60	200	172	133	1.50	-	10	164	6.9	-
中效系列 Medium Efficiency Range													
HDL125D	Al	6.3	RSCR	60	134	115	81	1.65	-	10	161	6.9	UL
HDL125D I	Cu/Al	6.3	RSCR	60	134	115	78	1.72	-	10	161	6.9	UL
HDL140D L	Al	7.0	RSCR	60	145	125	91	1.60	-	10	161	6.9	UL
HDL160D M	Al	7.5	RSCR	60	154	132	93	1.66	-	10	164	7.3	UL
HDL160D*	Al	8.0	RSCR	60	165	142	99	1.66	-	10	164	7.3	-
HDL180D*	Al	8.6	RSCR	60	180	155	106	1.70	-	10	164	7.3	-
HDL200D	Al	9.3	RSCR	60	200	172	119	1.68	-	10	164	7.3	UL
高效系列 High Efficiency Range													
HXL100D*	Cu	5.3	RSCR	60	110	95	61	1.80	-	6	164	7.6	-
HXL125D*	Cu	6.3	RSCR	60	134	115	74	1.80	-	6	164	7.6	-
HXL160D	Cu	8.0	RSCR	60	165	142	92	1.80	-	10	164	7.6	-
HXL180D*	Cu	8.6	RSCR	60	180	155	100	1.80	-	10	161	7.6	-
HXL200D*	Cu	9.3	RSCR	60	200	172	111	1.80	-	10	161	7.6	-
100V/50-60Hz													
普效系列 Standard Efficiency Range													
HML100J*	Al	6.3	RSCR	50	110	95	79	1.40	-	2	161	7.3	-
				60	128	110	85	1.50	-				
HML125J*	Al	7.0	RSCR	50	123	106	88	1.40	-	2	161	7.3	-
				60	142	122	95	1.50	-				
HML140J*	Al	8.0	RSCR	50	138	119	99	1.40	-	2	161	7.3	-
				60	160	132	107	1.50	-				
中效系列 Medium Efficiency Range													
HDL100J	Al	6.3	RSCR	50	110	95	64	1.72	-	10	161	7.3	-
				60	128	110	73	1.75	-				
HDL125J	Cu	7.0	RSCR	50	123	106	72	1.72	-	10	161	7.3	-
				60	142	122	80	1.78	-				
HDL140J*	Cu	8.0	RSCR	50	140	120	81	1.72	-	10	161	7.3	-
				60	160	138	91	1.75	-				

注 NOTE

冷却方式	Cooling Type
静态冷却	Static Cooling
应用条件	Application
低背压	LBP
*即将发布	Release on progress

测试工况

蒸发温度	Evaporating temperature	-23.3°C
冷凝温度	Condensing temperature	54.4°C
过冷温度	Subcooling temperature	32.2°C
吸气温度	Suction temperature	32.2°C
环境温度	Ambient temperature	32.2°C

TEST CONDITIONS(ASHRAE)

单位换算 CONVERSION

1 Watt = 3.41 Btu/h = 0.86 kcal/h

型号	电机	排气量	电机类型	频率	制冷量		输入功率	性能系数	启动电容	运行电容	高度	重量	认证
Model	Motor	Displ.	Motor Type	Freq.	Cooling Capacity	Cooling Capacity	Input Power	COP	Start Capacitor	Run Capacitor	Height	Net Weight	Certification
		cm ³		hz	w	kcal/h	w	w/w	μF	μF	mm	kg	

220-240V/50Hz

普效系列 Standard Efficiency Range

GML110A	AI	4.1	RSCR	50	113	97	84	1.35	-	2.5	152	6.3	CCC/VDE
GML125A	AI	4.3	RSCR	50	124	107	90	1.38	-	3	152	6.3	CCC/VDE
GML140A	AI	4.5	RSCR	50	140	120	104	1.35	-	3	152	6.3	CCC/VDE
GML160A	AI	5.7	RSCR	50	162	139	114	1.42	-	4	161	7.3	-
GML180A	AI	6.0	RSCR	50	178	153	125	1.42	-	4	164	7.3	CCC/VDE
GML200A M	AI	6.5	RSCR	50	190	163	128	1.48	-	5	164	7.3	CCC/VDE
GML200A	AI	7.0	RSCR	50	205	176	139	1.48	-	5	164	7.3	CCC/VDE

中效系列 Midium Efficiency Range

GDL140A	AI	4.9	RSCR	50	148	127	102	1.45	-	3	152	6.3	-
GDL160A	Cu/AI	5.7	RSCR	50	167	144	108	1.55	-	4	164	7.6	CCC
GDL200A M	Cu/AI	6.5	RSCR	50	195	163	119	1.60	-	5	164	7.6	CCC
GDL200A	Cu/AI	7	RSCR	50	205	176	135	1.52	-	5	164	7.6	CCC

高效系列 High Efficiency Range

GXL125A	Cu	4.3	RSCR	50	123	106	72	1.72	-	5	164	7.6	CCC
GXL140A	Cu	4.6	RSCR	50	138	119	80	1.72	-	5	164	7.6	-
GXL160A	Cu	5.7	RSCR	50	167	144	98	1.70	-	4	164	7.6	CCC/VDE
GXL200A M	Cu	6.5	RSCR	50	195	163	115	1.70	-	5	164	7.6	-
GXL200A	Cu	7	RSCR	50	205	176	120	1.70	-	5	164	7.6	CCC/VDE

220-240V/60Hz

普效系列 Standard Efficiency Range

GML140F	AI	4.3	RSCR	60	143	123	99	1.45	-	3	161	6.9	-
GML200F	AI	5.7	RSCR	60	200	172	138	1.45	-	4	164	7.2	-

中效系列 Midium Efficiency Range

GDL140F	AI	4.3	RSCR	60	143	123	92	1.55	-	3	164	7.2	-
GDL200F	Cu/AI	5.7	RSCR	60	200	172	129	1.55	-	4	164	7.3	-

高效系列 High Efficiency Range

GXL140F	Cu	4.3	RSCR	60	143	123	85	1.69	-	3	164	7.3	-
GXL200F	Cu	5.7	RSCR	60	200	172	120	1.67	-	4	164	7.3	-

220-240V/50-60Hz

普效系列 Standard Efficiency Range

GML70G	AI	2.9	RSCR	50	72	62	52	1.38	-	2	161	7.1	CCC/VDE
				60	86	74	59	1.45					
GML80G	AI	3.1	RSCR	50	80	69	58	1.38	-	2	152	6.3	CCC/VDE
				60	92	79	63	1.45					
GML90G	AI	3.4	RSCR	50	94	81	72	1.30	-	2.5	152	6.3	CCC/VDE
				60	110	95	76	1.45					
GML125G	AI	4.3	RSCR	50	122	105	90	1.35	-	3	161	7.3	CCC/VDE
				60	145	125	100	1.45					
GML140G	AI	4.5	RSCR	50	144	124	103	1.40	-	3	161	7.3	CCC/VDE
				60	168	144	108	1.55					
GML160G	AI	5.7	RSCR	50	162	139	114	1.42	-	4	161	7.3	CCC/VDE
				60	195	168	128	1.52					

注 NOTE

冷却方式	Cooling Type
静态冷却	Static Cooling
应用条件	Application
低背压	LBP
*即将发布	Release on progress

测试工况

蒸发温度	Evaporating temperature	-23.3°C
冷凝温度	Condensing temperature	54.4°C
过冷温度	Subcooling temperature	32.2°C
吸气温度	Suction temperature	32.2°C
环境温度	Ambient temperature	32.2°C

TEST CONDITIONS(ASHRAE)

单位换算 CONVERSION

1 Watt = 3.41 Btu/h = 0.86 kcal/h

型号	电机	排气量	电机类型	频率	制冷量		输入功率	性能系数	启动电容	运行电容	高度	重量	认证
Model	Motor	Displ.	Motor Type	Freq.	Cooling Capacity	Cooling Capacity	Input Power	COP	Start Capacitor	Run Capacitor	Height	Net Weight	Certification
		cm ³		hz	w	kcal/h	w	w/w	μF	μF	mm	kg	

220-240V/50-60Hz

中效系列 Midium Efficiency Range

GDL125G	Al	4.3	RSCR	50	123	106	82	1.50	-	3	164	7.2	CCC
				60	143	123	89	1.60					
GDL140G	Al/Cu	4.9	RSCR	50	149	128	99	1.50	-	3	164	7.2	CCC
				60	175	151	109	1.60					
GDL160G	Cu/Al	5.7	RSCR	50	167	144	111	1.50	-	4	164	7.3	CCC
				60	200	175	125	1.60					

高效系列 High Efficiency Range

GXL125G	Cu	4.3	RSCR	50	123	106	74	1.67	-	3	164	7.6	CCC
				60	143	123	83	1.72					
GXL140G	Cu	4.9	RSCR	50	149	128	89	1.67	-	3	164	7.6	CCC
				60	175	151	102	1.72					
GXL160G	Cu	5.7	RSCR	50	167	144	103	1.62	-	4	164	7.6	CCC
				60	200	175	120	1.66					

160-260V/50Hz

普效系列 Standard Efficiency Range

GML110A T	Al	4.1	RSCR	50	113	97	87	1.30	-	2.5	152	6.3	CCC/VDE
GML125A T	Al	4.3	RSCR	50	123	106	94	1.30	-	3	152	6.3	-
GML140A T	Al	4.9	RSCR	50	148	127	110	1.35	-	3	161	6.9	CCC/VDE
GML160A T	Al	5.7	RSCR	50	162	139	114	1.42	-	4	164	7.3	-

中效系列 Midium Efficiency Range

GDL110A T	Al	4.1	RSCR	50	113	97	75	1.50	-	2.5	164	7.2	CCC/VDE
GDL125A T	Al	4.3	RSCR	50	123	106	82	1.50	-	3	164	7.2	-
GDL140A T	Al	4.9	RSCR	50	148	127	99	1.50	-	3	164	7.2	CCC/VDE
GDL160A T	Cu/Al	5.7	RSCR	50	162	139	108	1.50	-	4	164	7.3	-

高效系列 High Efficiency Range

GXL110A T	Cu	4.1	RSCR	50	113	97	71	1.60	-	2.5	164	7.6	CCC/VDE
GXL125A T	Cu	4.3	RSCR	50	123	106	77	1.60	-	3	164	7.6	-
GXL140A T	Cu	4.9	RSCR	50	148	127	93	1.60	-	3	164	7.6	CCC/VDE
GXL160A T	Cu	5.7	RSCR	50	162	139	101	1.60	-	4	164	7.6	-

注 NOTE

冷却方式	Cooling Type
静态冷却	Static Cooling
应用条件	Application
低背压	LBP
*即将发布	Release on progress

测试工况

TEST CONDITIONS(ASHRAE)	
蒸发温度	Evaporating temperature -23.3°C
冷凝温度	Condensing temperature 54.4°C
过冷温度	Subcooling temperature 32.2°C
吸气温度	Suction temperature 32.2°C
环境温度	Ambient temperature 32.2°C

单位换算 CONVERSION

1 Watt = 3.41 Btu/h = 0.86 kcal/h

型号	电机	排气量	电机类型	频率	制冷量		输入功率	性能系数	启动电容	运行电容	高度	重量	认证
Model	Motor	Displ.	Motor Type	Freq.	Cooling Capacity	Cooling Capacity	Input Power	COP	Start Capacitor	Run Capacitor	Height	Net Weight	Certification
		cm ³		hz	w	kcal/h	w	w/w	μF	μF	mm	kg	

115V/60Hz 北美电压 North American Range

普效系列 Standard Efficiency Range

GML125D M	AI	3.7	RSCR	60	125	108	86	1.45	-	10	152	6.3	-
GML125D	AI	4.1	RSCR	60	136	117	94	1.45	-	10	152	6.3	UL
GML145D	AI	4.3	RSCR	60	145	125	92	1.57	-	10	164	7.1	UL
GML160D	AI	4.5	RSCR	60	160	138	103	1.56	-	10	164	7.3	-
GML175D	AI	4.9	RSCR	60	170	146	109	1.56	-	10	164	7.3	UL
GML190D	AI	5.3	RSCR	60	190	163	136	1.40	-	10	164	7.3	-
GML200D	AI	5.7	RSCR	60	200	172	143	1.40	-	10	164	7.3	UL

中效系列 Medium Efficiency Range

GDL145D	Cu	4.3	RSCR	60	145	125	88	1.65	-	10	161	7.3	UL
GDL160D	Cu	4.5	RSCR	60	160	138	97	1.65	-	10	161	7.3	-
GDL175D	Cu	4.9	RSCR	60	175	151	106	1.65	-	10	161	7.3	UL
GDL200D M	Cu	5.3	RSCR	60	190	163	115	1.65	-	10	164	7.3	UL
GDL200D	Cu	5.7	RSCR	60	200	172	121	1.65	-	10	161	7.3	UL

高效系列 High Efficiency Range

GXL160D	Cu	4.5	RSCR	60	160	138	93	1.73	-	10	164	7.6	-
GXL175D	Cu	4.9	RSCR	60	175	151	101	1.73	-	10	164	7.6	UL
GXL200D M	Cu	5.3	RSCR	60	190	163	110	1.73	-	10	164	7.6	UL
GXL200D	Cu	5.7	RSCR	60	200	172	116	1.73	-	10	164	7.6	UL

100V/50-60Hz 日本电压 Japan Range

普效系列 Standard Efficiency Range

GML110J	AI	4.1	RSCR	50	110	95	78	1.41	-	10	164	7.3	-
				60	125	108	85	1.47					
GML140J	AI	4.9	RSCR	50	145	125	100	1.45	-	10	164	7.3	-
				60	160	138	107	1.50					

中效系列 Medium Efficiency Range

GDL110J	Cu	4.1	RSCR	50	110	95	73	1.50	-	10	164	7.6	-
				60	125	108	78	1.60					
GDL140J	Cu	4.9	RSCR	50	145	125	97	1.50	-	10	164	7.6	-
				60	160	138	100	1.60					

注 NOTE

冷却方式	Cooling Type
静态冷却	Static Cooling
应用条件	Application
低背压	LBP
*即将发布	Release on progress

测试工况

蒸发温度	Evaporating temperature	-23.3°C
冷凝温度	Condensing temperature	54.4°C
过冷温度	Subcooling temperature	32.2°C
吸气温度	Suction temperature	32.2°C
环境温度	Ambient temperature	32.2°C

TEST CONDITIONS(ASHRAE)

单位换算 CONVERSION

1 Watt = 3.41 Btu/h = 0.86 kcal/h

型号	电机	排气量	电机类型	频率	制冷量		输入功率	性能系数	运行电容	高度	重量	认证
Model	Motor	Displ.	Motor Type	Freq.	Cooling Capacity	Cooling Capacity	Input Power	COP	Run Capacitor	Height	Net Weight	Certification
		cm ³		hz	w	kcal/h	w	w/w	μF	mm	kg	
220-240V/50Hz												
中效系列 Medium Efficiency Range												
HDZ100A M	AI	5.4	RSCR	50	92	79	52	1.78	2	163	7.3	CCC/VDE
HDZ100A	AI	5.7	RSCR	50	98	84	55	1.78	2	163	7.3	CCC/VDE
HDZ125A	AI	7.0	RSCR	50	126	108	70	1.80	2.5	163	7.3	CCC/VDE
HDZ140A	AI	7.5	RSCR	50	135	116	75	1.80	3	163	7.3	CCC/VDE
HDZ155A	AI	8.6	RSCR	50	155	133	87	1.78	4	163	7.3	CCC/VDE
HDZ170A	AI	9.2	RSCR	50	170	146	96	1.78	4	163	7.3	CCC/VDE
高效系列 High Efficiency Range												
HXZ100A	AI	5.7	RSCR	50	98	84	53	1.85	2	163	7.3	CCC/VDE
HXZ125A	AI	7.0	RSCR	50	126	108	68	1.86	2.5	163	7.3	CCC/VDE
HXZ140A	AI	7.5	RSCR	50	135	116	73	1.85	3	163	7.3	CCC/VDE
HXZ155A	AI	8.6	RSCR	50	155	133	84	1.84	4	163	7.3	-
HXZ170A	AI	9.2	RSCR	50	170	146	93	1.83	4	163	7.3	CCC/VDE
超高效系列 Top Efficiency Range												
HPZ100A	Cu	5.7	RSCR	50	98	84	51	1.94	2	163	7.9	CCC/VDE
HPZ125A	Cu	7.0	RSCR	50	126	108	65	1.95	2.5	163	7.9	CCC/VDE
HPZ140A	Cu	7.5	RSCR	50	135	116	68	1.98	2.5	163	7.9	CCC/VDE
HPZ155A	Cu	8.6	RSCR	50	155	133	79	1.95	4	163	7.9	CCC/VDE
HPZ170A	Cu	9.2	RSCR	50	170	146	88	1.93	4	163	7.9	CCC/VDE
220-240V/60Hz												
中效系列 Medium Efficiency Range												
HDZ100F	AI	4.9	RSCR	60	96	83	55	1.74	1.5	163	7.3	-
HDZ125F	AI	5.7	RSCR	60	125	108	71	1.76	2	163	7.3	-
HDZ140F	AI	7.0	RSCR	60	144	124	80	1.79	2.5	163	7.3	-
HDZ160F	AI	8.0	RSCR	60	170	146	96	1.78	3	163	7.3	-
HDZ190F	AI	9.2	RSCR	60	190	163	107	1.78	4	163	7.3	CB
115V/60Hz												
普效系列 Standard Efficiency Range												
HDZ100D	AI	5.3	RSCR	60	110	95	63	1.75	10	163	7.3	-
HDZ125D	AI	6.3	RSCR	60	125	108	71	1.75	10	163	7.3	UL
HDZ140D*	AI	7.0	RSCR	60	144	124	82	1.75	10	163	7.3	-
HDZ160D*	AI	8.0	RSCR	60	170	146	97	1.75	10	163	7.3	-
高效系列 High Efficiency Range												
HXZ100D*	AI	5.3	RSCR	60	110	95	61	1.80	10	163	7.3	-
HXZ125D*	AI	6.3	RSCR	60	125	108	69	1.80	10	163	7.3	-
HXZ140D*	AI	7.0	RSCR	60	144	124	80	1.80	10	163	7.3	-
HXZ160D*	AI	8.0	RSCR	60	170	146	94	1.80	10	163	7.3	-

注 NOTE

冷却方式	Cooling Type
静态冷却	Static Cooling
应用条件	Application
低背压	LBP
*即将发布	Release on progress

测试工况

蒸发温度	Evaporating temperature	-23.3°C
冷凝温度	Condensing temperature	54.4°C
过冷温度	Subcooling temperature	32.2°C
吸气温度	Suction temperature	32.2°C
环境温度	Ambient temperature	32.2°C

TEST CONDITIONS(ASHRAE)

单位换算 CONVERSION

1 Watt = 3.41 Btu/h = 0.86 kcal/h

型号	电机	排气量	电机类型	频率	制冷量		输入功率	性能系数	运行电容	高度	重量	认证
Model	Motor	Displ.	Motor Type	Freq.	Cooling Capacity	Cooling Capacity	Input Power	COP	Run Capacitor	Height	Net Weight	Certification
		cm ³		hz	w	kcal/h	w	w/w	μF	mm	kg	

220-240V/50Hz

普效系列 Standard Efficiency Range

HMM90A	AI	5.5	RSCR	50	92	79	66	1.40	2	162	5.4	CCC
HMM100A	AI	6.0	RSCR	50	100	86	69	1.45	2	162	5.4	CCC
HMM125A	AI	7.2	RSCR	50	125	108	86	1.45	2.5	162	5.4	CCC
HMM140A	AI	8.0	RSCR	50	140	120	97	1.45	3	162	5.4	-

中效系列 Midium Efficiency Range

HDM90A	AI	5.5	RSCR	50	92	79	61	1.50	2	162	5.4	CCC
HDM100A	AI	6.0	RSCR	50	100	86	65	1.55	2	162	5.4	CCC
HDM125A	AI	7.2	RSCR	50	125	108	81	1.55	2.5	162	5.4	CCC
HDM140A	AI	8.0	RSCR	50	140	120	90	1.55	3	165	5.6	-

高效系列 High Efficiency Range

HXM90A	AI	5.5	RSCR	50	92	79	58	1.60	2	165	5.8	-
HXM100A	AI	6.0	RSCR	50	100	86	61	1.65	2	165	5.8	-
HXM125A	AI	7.2	RSCR	50	125	108	76	1.65	2.5	165	5.8	-
HXM140A	AI	8.0	RSCR	50	140	120	85	1.65	3	165	5.8	-

115V/60Hz

普效系列 Standard Efficiency Range

HMM100D	AI	4.9	RSCR	60	98	84	70	1.40	8	162	5.4	-
HMM125D	AI	6.0	RSCR	60	120	103	83	1.45	10	162	5.4	-

中效系列 Midium Efficiency Range

HDM100D	AI	4.9	RSCR	60	98	84	65	1.50	8	162	5.4	-
HDM125D	AI	6.0	RSCR	60	120	103	77	1.55	10	162	5.4	-

220-240V/50-60Hz

普效系列 Standard Efficiency Range

HMM90G	AI	5.5	RSCR	50	92	79	68	1.35	2	162	5.4	-
				60	110	95	76	1.45				
HMM100G	AI	6.0	RSCR	50	100	86	74	1.35	2	162	5.4	-
				60	120	103	83	1.45				

100V/50-60Hz

普效系列 Standard Efficiency Range

HMM90J	AI	5.5	RSCR	50	92	79	71	1.30	2	162	5.4	-
				60	110	95	79	1.40				
HMM100J	AI	6.0	RSCR	50	100	86	71	1.30	2	162	5.4	-
				60	120	103	86	1.40				

160-260V/50Hz

普效系列 Standard Efficiency Range

HMM90A T	AI	5.5	RSCR	50	92	79	71	1.30	2	162	5.4	CCC
HMM100A T	AI	6.0	RSCR	50	100	86	74	1.35	2	162	5.4	CCC

注 NOTE

冷却方式	Cooling Type
静态冷却	Static Cooling
应用条件	Application
低背压	LBP
*即将发布	Release on progress

测试工况

TEST CONDITIONS(ASHRAE)	
蒸发温度	Evaporating temperature -23.3°C
冷凝温度	Condensing temperature 54.4°C
过冷温度	Subcooling temperature 32.2°C
吸气温度	Suction temperature 32.2°C
环境温度	Ambient temperature 32.2°C

单位换算 CONVERSION

1 Watt = 3.41 Btu/h = 0.86 kcal/h

型号	电机	排气量	电机类型	频率	制冷量		输入功率	性能系数	运行电容	高度	重量	认证
Model	Motor	Displ.	Motor Type	Freq.	Cooling Capacity	Cooling Capacity	Input Power	COP	Run Capacitor	Height	Net Weight	Certification
		cm ³		hz	w	kcal/h	w	w/w	μF	mm	kg	
220-240V/50Hz												
普效系列 Standard Efficiency Range												
GMM100A	AI	3.8	RSCR	50	100	86	71	1.40	2.5	162	5.4	-
GMM125A	AI	4.5	RSCR	50	125	108	89	1.40	2.5	165	5.6	-
GMM140A	AI	4.9	RSCR	50	140	120	100	1.40	3	165	5.6	-
中效系列 Midium Efficiency Range												
GDM100A	AI	3.8	RSCR	50	100	86	67	1.50	2.5	165	5.8	-
GDM125A	AI	4.5	RSCR	50	125	108	83	1.50	2.5	165	5.8	-
GDM140A	AI	4.9	RSCR	50	140	120	93	1.50	3	165	5.8	-
160-260V/50Hz												
普效系列 Standard Efficiency Range												
GMM100A T	AI	3.8	RSCR	60	100	86	77	1.30	2.5	162	5.4	-

注 NOTE

冷却方式	Cooling Type
静态冷却	Static Cooling
应用条件	Application
低背压	LBP
*即将发布	Release on progress

测试工况

蒸发温度	Evaporating temperature	-23.3°C
冷凝温度	Condensing temperature	54.4°C
过冷温度	Subcooling temperature	32.2°C
吸气温度	Suction temperature	32.2°C
环境温度	Ambient temperature	32.2°C

TEST CONDITIONS(ASHRAE)
单位换算 CONVERSION

1 Watt = 3.41 Btu/h = 0.86 kcal/h



Variable Speed Range 变频系列

R600a

型号	电机	频率	排气量	电机类型	制冷量		输入功率	性能系数	高度	重量	认证
Model	Motor	Freq.	Displ.	Motor Type	Cooling Capacity	Cooling Capacity	Input Power	COP	Height	Net Weight	Certification
		hz	cm ³		w	kcal/h	w	w/w	mm	kg	

Z系列变频压缩机 Z Series VSC

220-240V/50Hz,60Hz

普效系列 Medium Efficiency Range

HDZ240FSM*	AL	43(1300rpm)	10.3	PMSM	74	64	44	1.68	135.4	6.4	-
		53(1600rpm)			102	88	57	1.78			
		80(2400rpm)			153	132	84	1.82			
		100(3000rpm)			188	162	105	1.79			
		140(4200rpm)			234	201	140	1.67			
HDZ270FSM*	AL	43(1300rpm)	11.4	PMSM	83	71	52	1.61	135.4	6.4	-
		53(1600rpm)			109	94	63	1.74			
		80(2400rpm)			169	145	94	1.80			
		100(3000rpm)			213	183	120	1.78			
		140(4200rpm)			250	215	153	1.63			

高效系列 High Efficiency Range

HXZ170FSM	AL	43(1300rpm)	7.26	PMSM	53	46	30	1.75	140.4	6.8	-
		53(1600rpm)			71	61	38	1.85			
		80(2400rpm)			106	91	56	1.89			
		100(3000rpm)			132	114	70	1.88			
		140(4200rpm)			170	146	97	1.75			
HXZ200FSM	AL	43(1300rpm)	8.6	PMSM	62	53	35	1.78	140.4	6.8	-
		53(1600rpm)			81	70	43	1.89			
		80(2400rpm)			125	108	66	1.90			
		100(3000rpm)			155	133	82	1.89			
		140(4200rpm)			203	175	115	1.77			
HXZ220FSM	AL	43(1300rpm)	9.2	PMSM	67	58	38	1.78	140.4	6.8	-
		53(1600rpm)			90	77	48	1.89			
		80(2400rpm)			134	115	70	1.91			
		100(3000rpm)			166	143	87	1.90			
		140(4200rpm)			217	187	123	1.77			
HXZ240FSM	AL	43(1300rpm)	10.3	PMSM	74	64	42	1.78	140.4	6.8	-
		53(1600rpm)			102	88	54	1.88			
		80(2400rpm)			153	132	80	1.91			
		100(3000rpm)			188	162	99	1.89			
		140(4200rpm)			234	201	132	1.77			
HXZ270FSM	AL	43(1300rpm)	11.4	PMSM	83	71	49	1.71	140.4	6.8	-
		53(1600rpm)			109	94	59	1.84			
		80(2400rpm)			169	145	89	1.90			
		100(3000rpm)			213	183	114	1.87			
		140(4200rpm)			250	215	145	1.72			

注 NOTE

冷却方式	Cooling Type
静态冷却	Static Cooling
应用条件	Application
低背压	LBP
*即将发布	Release on progress

测试工况

蒸发温度	Evaporating temperature	-23.3°C
冷凝温度	Condensing temperature	54.4°C
过冷温度	Subcooling temperature	32.2°C
吸气温度	Suction temperature	32.2°C
环境温度	Ambient temperature	32.2°C

TEST CONDITIONS(ASHRAE)

单位换算 CONVERSION

1 Watt = 3.41 Btu/h = 0.86 kcal/h



Variable Speed Range 变频系列

R600a

型号	电机	频率	排气量	电机类型	制冷量		输入功率	性能系数	高度	重量	认证
Model	Motor	Freq.	Displ.	Motor Type	Cooling Capacity	Cooling Capacity	Input Power	COP	Height	Net Weight	Certification
		hz	cm ³		w	kcal/h	w	w/w	mm	kg	

M系列变频压缩机 M Series VSC

220-240V/50Hz, 60Hz

普效系列 Standard Efficiency Range

HMM120FSM*	AL	43(1300rpm)	5.3	PMSM	33	28	21	1.55	135.4	5.8	-
		53(1600rpm)			52	45	32	1.65			
		80(2400rpm)			77	66	45	1.70			
		100(3000rpm)			96	83	57	1.68			
		140(4200rpm)			125	108	78	1.60			
HMM170FSM*	AL	43(1300rpm)	7.26	PMSM	47	40	29	1.60	135.4	5.8	-
		53(1600rpm)			71	61	42	1.70			
		80(2400rpm)			106	91	61	1.75			
		100(3000rpm)			132	114	78	1.70			
HMM200FSM*	AL	43(1300rpm)	8.6	PMSM	55	47	34	1.60	135.4	5.8	-
		53(1600rpm)			81	70	48	1.70			
		80(2400rpm)			125	108	71	1.75			
		100(3000rpm)			155	133	91	1.70			
HMM220FSM*	AL	43(1300rpm)	9.2	PMSM	60	52	38	1.60	135.4	5.8	-
		53(1600rpm)			90	77	53	1.70			
		80(2400rpm)			134	115	77	1.75			
		100(3000rpm)			166	143	98	1.70			
		140(4200rpm)			225	194	136	1.65			

中效系列 Medium Efficiency Range

HDM120FSM*	AL	43(1300rpm)	5.3	PMSM	33	28	21	1.60	135.4	6	-
		53(1600rpm)			52	45	31	1.70			
		80(2400rpm)			77	66	44	1.75			
		100(3000rpm)			96	83	55	1.73			
		140(4200rpm)			125	108	76	1.65			
HDM170FSM*	AL	43(1300rpm)	7.26	PMSM	47	40	28	1.65	135.4	6	-
		53(1600rpm)			71	61	41	1.75			
		80(2400rpm)			106	91	59	1.80			
		100(3000rpm)			132	114	74	1.78			
HDM200FSM*	AL	43(1300rpm)	8.6	PMSM	55	47	33	1.68	135.4	6	-
		53(1600rpm)			81	70	46	1.78			
		80(2400rpm)			125	108	69	1.80			
		100(3000rpm)			155	133	87	1.79			
HDM220FSM*	AL	43(1300rpm)	9.2	PMSM	60	52	36	1.68	135.4	6	-
		53(1600rpm)			90	77	51	1.78			
		80(2400rpm)			134	115	74	1.80			
		100(3000rpm)			166	143	93	1.79			
		140(4200rpm)			225	194	135	1.67			

注 NOTE

冷却方式	Cooling Type
静态冷却	Static Cooling
应用条件	Application
低背压	LBP
*即将发布	Release on progress

测试工况

蒸发温度	Evaporating temperature	-23.3°C
冷凝温度	Condensing temperature	54.4°C
过冷温度	Subcooling temperature	32.2°C
吸气温度	Suction temperature	32.2°C
环境温度	Ambient temperature	32.2°C

TEST CONDITIONS(ASHRAE)

单位换算 CONVERSION

1 Watt = 3.41 Btu/h = 0.86 kcal/h



Variable Speed Range 变频系列

R600a

型号	电机	频率	排气量	电机类型	制冷量		输入功率	性能系数	高度	重量	认证
Model	Motor	Freq.	Displ.	Motor Type	Cooling Capacity	Cooling Capacity	Input Power	COP	Height	Net Weight	Certification
		hz	cm ³		w	kcal/h	w	w/w	mm	kg	

T系列变频压缩机 T Series VSC

220-240V/50Hz, 60Hz

HKD86FSK I	Cu	47(1400rpm)	8.6	PMSM	60	52	33	1.83	163	8.0	-
		53(1600rpm)			81	70	42	1.94			
		80(2400rpm)			121	104	62	1.95			
		100(3000rpm)			151	130	78	1.94			
		133(4000rpm)			190	163	104	1.83			
HKD93FSK I	Cu	47(1400rpm)	9.3	PMSM	70	60	38	1.83	163	8.0	-
		53(1600rpm)			87	75	45	1.94			
		80(2400rpm)			130	112	67	1.95			
		100(3000rpm)			163	140	84	1.94			
		133(4000rpm)			210	181	115	1.83			
HKD10FSK I	Cu	47(1400rpm)	10.5	PMSM	83	71	45	1.83	163	8.0	CCC
		53(1600rpm)			95	82	49	1.93			
		80(2400rpm)			142	122	73	1.95			
		100(3000rpm)			178	153	92	1.94			
		133(4000rpm)			235	202	128	1.83			
HKD12FSK I	Cu	47(1400rpm)	11.5	PMSM	95	82	53	1.80	163	8.0	CCC
		53(1600rpm)			109	94	58	1.89			
		80(2400rpm)			166	143	85	1.95			
		100(3000rpm)			208	179	108	1.92			
		133(4000rpm)			250	215	139	1.80			

注 NOTE

冷却方式	Cooling Type
静态冷却	Static Cooling
应用条件	Application
低背压	LBP
*即将发布	Release on progress

测试工况

TEST CONDITIONS(ASHRAE)	
蒸发温度	Evaporating temperature -23.3°C
冷凝温度	Condensing temperature 54.4°C
过冷温度	Subcooling temperature 32.2°C
吸气温度	Suction temperature 32.2°C
环境温度	Ambient temperature 32.2°C

单位换算 CONVERSION

1 Watt = 3.41 Btu/h = 0.86 kcal/h



Variable Speed Range 变频系列

R134a

型号	电机	频率	排气量	电机类型	制冷量		输入功率	性能系数	高度	重量	认证
Model	Motor	Freq.	Displ.	Motor Type	Cooling Capacity	Cooling Capacity	Input Power	COP	Height	Net Weight	Certification
		hz	cm ³		w	kcal/h	w	w/w	mm	kg	

T系列变频压缩机 T Series VSC

115V-127V/50Hz, 60Hz

GKD44FDK	AL	47(1400rpm)	4.4	PMSM	63	54	37	1.70	163	7.1	-
		53(1600rpm)			72	62	40	1.78			
		80(2400rpm)			108	93	60	1.80			
		100(3000rpm)			135	116	76	1.78			
		133(4000rpm)			181	156	106	1.70			
GKD75FDK	AL	47(1400rpm)	7.5	PMSM	100	86	58	1.73	163	7.1	-
		53(1600rpm)			114	98	62	1.84			
		80(2400rpm)			171	147	92	1.86			
		100(3000rpm)			214	184	117	1.83			
		133(4000rpm)			273	235	160	1.71			

R290

115V-127V/50Hz, 60Hz

NKD57FDK	Cu	47(1400rpm)	5.6	PMSM	130	112	79	1.65	173	8.0	-
		53(1600rpm)			148	127	86	1.72			
		80(2400rpm)			222	191	127	1.75			
		100(3000rpm)			277	238	160	1.73			
		133(4000rpm)			370	318	224	1.65			
NKD66FDK	Cu	47(1400rpm)	6.6	PMSM	150	129	91	1.65	173	8.0	-
		53(1600rpm)			171	147	99	1.72			
		80(2400rpm)			257	221	147	1.75			
		100(3000rpm)			321	276	186	1.73			
		133(4000rpm)			430	370	261	1.65			
NKD75FDK	Cu	47(1400rpm)	7.5	PMSM	175	151	106	1.65	173	8.0	-
		53(1600rpm)			200	172	116	1.73			
		80(2400rpm)			300	258	171	1.75			
		100(3000rpm)			375	323	217	1.73			
		133(4000rpm)			500	430	303	1.65			

注 NOTE

冷却方式	Cooling Type
静态冷却	Static Cooling
应用条件	Application
低背压	LBP
*即将发布	Release on progress

测试工况

TEST CONDITIONS(ASHRAE)	
蒸发温度	Evaporating temperature -23.3°C
冷凝温度	Condensing temperature 54.4°C
过冷温度	Subcooling temperature 32.2°C
吸气温度	Suction temperature 32.2°C
环境温度	Ambient temperature 32.2°C

单位换算 CONVERSION

1 Watt = 3.41 Btu/h = 0.86 kcal/h



Commercial Product Range 商用产品系列

Tau & LAMBDA R134a

型号	电机	频率	排气量	电机类型	制冷量	输入功率	性能系数	启动电容	运行电容	高度	重量	认证	冷却方式
Model	Motor	Freq.	Displ.	Motor Type	Cooling Capacity	Input Power	COP	Start Capacitor	Run Capacitor	Height	Net Weight	Certification	Cooling Type
			cm ³		w	w	w/w	µF	µF	mm	kg		S/F

HMBP Range 中高背压系列 (+7.2°C/+54.4°C)

220-240V/50Hz

GL90TB	Al	50	7.5	CSIR	760	335	2.27	50	-	184	10.0	CCC/VDE	F
GL90TB B	Cu	50	8.6	CSIR	870	387	2.25	50	-	184	10.2	CCC/VDE	F
GL10TB	Cu	50	9.3	CSIR	930	413	2.25	50	-	184	10.2	CCC/VDE	F
GL12TB	Cu	50	11.4	CSIR	1100	489	2.25	50	-	184	10.2	CCC/VDE	F

200-220V/50Hz, 220-230V/60Hz

GL60TG	Cu/Al	50	5.3	CSIR	540	240	2.25	50	-	174	8.8	CCC/VDE	F
		60			640	262	2.44						
GL90TG*	Cu	50	7.5	CSCR	740	240	2.25	50	6	184	10.2	-	F
		60			880	262	2.44						

LBP Range 低背压系列

220-240V/50Hz

GTM93AA	Cu	50	10.0	RSCR	280	207	1.35	-	6	184	9.5	CCC/VDE	S
GTM93AA e	Al	50	10.0	CSCR	280	207	1.35	50	4	184	9.5	CCC/VDE	S
GTM10AA s	Cu	50	10.6	CSIR	300	226	1.33	50	-	184	9.6	CCC/VDE	F
GTM10AA e	Al	50	10.6	CSCR	300	226	1.33	50	4	184	9.6	CCC/VDE	F
GTM12AA e	Al	50	11.0	CSCR	320	241	1.33	50	4	184	9.6	CCC/VDE	F
GTM12AA s	Cu	50	12.0	CSIR	340	256	1.33	50	-	184	9.8	CCC/VDE	F

200-220V/50Hz, 220-230V/60Hz

GTM93AG	Cu	50	9.3	CSIR	248	216	1.15	50	-	184	9.6	CCC/VDE	F
		60			290	220	1.32						

注 NOTE

冷却方式	Cooling Type
静态冷却	Static Cooling
应用条件	Application
低背压	LBP
*即将发布	Release on progress

测试工况

TEST CONDITIONS(ASHRAE)	
蒸发温度	Evaporating temperature -23.3°C
冷凝温度	Condensing temperature 54.4°C
过冷温度	Subcooling temperature 32.2°C
吸气温度	Suction temperature 32.2°C
环境温度	Ambient temperature 32.2°C

单位换算 CONVERSION

1 Watt = 3.41 Btu/h = 0.86 kcal/h



Commercial Product Range 商用产品系列

R290

型号	电机	频率	排气量	电机类型	制冷量	输入功率	性能系数	启动电容	运行电容	高度	重量	认证	冷却方式
Model	Motor	Freq.	Displ.	Motor Type	Cooling Capacity	Input Power	COP	Start Capacitor	Run Capacitor	Height	Net Weight	Certification	Cooling Type
			cm ³		w	w	w/w	µF	µF	mm	kg		S/F

LBP Range 低背压系列

220-240V/50Hz

中效系列 Medium Efficiency Range

Tau系列

NLT53AA	Al	50	5.3	RSCR	237	153	1.55	-	6	184	9.6	CCC/VDE	F
NLT57AA	Al	50	5.7	RSCR	257	166	1.55	-	5	184	9.6	CCC/VDE	F
NLT61AA	Al	50	6.1	RSCR	284	183	1.55	-	5	184	9.6	CCC/VDE	F
NLT66AA s	Al	50	6.6	CSCR	308	199	1.55	50	5	184	9.6		F
NLT75AA s	Al	50	7.5	CSCR	358	231	1.55	50	5	184	9.6		F
NLT80AA s	Al	50	8.0	CSCR	380	245	1.55	50	8	184	9.6	CCC/VDE	F
NLT86AA I	Cu	50	8.6	CSCR	420	275	1.53	50	8	184	10.7		F
NLT93AA I	Cu	50	9.3	CSCR	450	292	1.54	50	8	184	10.7		F

高效系列 High Efficiency Range

NLT53AA I	Cu	50	5.3	RSCR	237	144	1.65	-	5	184	10.7	CCC/VDE	F
NLT57AA I	Cu	50	5.7	RSCR	257	156	1.65	-	6	184	10.7	CCC/VDE	F
NLT61AA I	Cu	50	6.1	RSCR	284	172	1.65	-	6	184	10.7	CCC/VDE	F
NLT66AA I	Cu	50	6.6	CSCR	308	187	1.65	50	6	184	10.7	CCC/VDE	F
NLT75AA I	Cu	50	7.5	CSCR	358	217	1.65	50	5	184	10.7	CCC/VDE	F
NLT80AA I	Cu	50	8.0	CSCR	380	230	1.65	50	8	184	10.7		F

220-240V/50Hz

Lambda系列

NLL160A	Al	50	3.7	RSCR	165	110	1.50	-	4	164	7.3	-	S
NLL200A	Al	50	4.6	RSCR	210	140	1.50	-	5	164	7.3	CCC/VDE	S
NLL200A I	Cu	50	4.6	RSCR	210	130	1.62	-	5	164	7.6	CCC/VDE	S

115V/60Hz

Tau系列

NLT40AD	Cu	60	4.0	RSCR	230	144	1.60	-	10	184	10.7	-	S
NLT44AD	Cu	60	4.4	RSCR	245	153	1.60	-	10	184	10.7	-	F
NLT53AD	Cu	60	5.3	CSCR	290	181	1.60	50	4	184	10.7	-	F
NLT57AD	Cu	60	5.7	CSCR	310	194	1.60	50	4	184	10.7	UL	F

115V/60Hz

Lambda系列

NLL155D	Cu/Al	60	3.4	RSCR	155	97	1.60	-	10	164	7.6	-	S
NLL175D	Cu/Al	60	3.4	RSCR	172	108	1.60	-	10	164	7.6	UL	S
NLL200D	Cu/Al	60	3.7	RSCR	200	125	1.60	-	10	164	7.6	TUV	S

MBP Range 中背压系列 (-6.7°C/+54.4°C)

220-240V/50Hz

NLT44AA	Al	50	4.4	RSCR	385	193	2.00	-	6	184	9.6	CCC/VDE	S
NLT53AA	Al	50	5.3	RSCR	442	221	2.00	-	6	184	9.6	CCC/VDE	F
NLT57AA	Al	50	5.7	RSCR	475	238	2.00	-	5	184	9.6	CCC/VDE	F
NLT61AA	Al	50	6.1	RSCR	510	255	2.00	-	5	184	9.6	CCC/VDE	F
NMT66AA	Cu	50	6.6	CSCR	550	268	2.05	50	5	184	10.7	-	F
NMT75AA	Cu	50	7.5	CSCR	570	285	2.00	50	5	184	10.7	-	F

注 NOTE

冷却方式	Cooling Type
静态冷却	Static Cooling
应用条件	Application
低背压	LBP
*即将发布	Release on progress

测试工况

蒸发温度	Evaporating temperature	-23.3°C
冷凝温度	Condensing temperature	54.4°C
过冷温度	Subcooling temperature	32.2°C
吸气温度	Suction temperature	32.2°C
环境温度	Ambient temperature	32.2°C

单位换算 CONVERSION

1 Watt = 3.41 Btu/h = 0.86 kcal/h

型号	电机	排气量	电机类型	频率	制冷量		输入功率	性能系数	运行电容	高度	重量	认证
Model	Motor	Displ.	Motor Type	Freq.	Cooling Capacity	Cooling Capacity	Input Power	COP	Run Capacitor	Height	Net Weight	Certification
		cm ³		hz	w	kcal/h	w	w/w	μF	mm	kg	
220-240V/50Hz												
HPKD190A	Al	11.4	RSCR	50	212	182	123	1.72	5	184	9.6	CCC/VDE
HPKX190A	Cu	11.4	RSCR	50	212	182	115	1.85	5	184	10.1	CCC/VDE
HTH14AA	Al	14.0	RSCR	50	235	202	168	1.40	5	184	9.3	CCC/VDE
HTH14AA I	Al	14.0	RSCR	50	235	202	149	1.58	5	184	9.3	CCC/VDE
HKD14AA	Cu	14.0	RSCR	50	240	206	140	1.72	6	184	10.1	CCC/VDE
220-240V/50-60Hz												
HPKD200G	Cu/Al	12.0	RSCR	50	201	173	139	1.65	5	184	10.1	CCC/VDE
				60	245	211	142	1.72				
115V/60Hz												
HPKD240D*	Cu/Al	12.0	RSCR	60	245	211	153	1.60	10	184	10	-
HPKX240D*	Cu	12.0	RSCR	60	245	211	148	1.65	10	184	10	-
100V/50-60Hz												
HTH11AJ	Cu	11.0	RSCR	50	182	157	115	1.58	8	174	9	-
				60	200	172	125	1.60				
HTT10AJ	Cu	10.0	RSCR	50	173	149	98	1.77	10	184	10	-
				60	195	168	110	1.78				

注 NOTE

冷却方式	Cooling Type
静态冷却	Static Cooling
应用条件	Application
低背压	LBP
*即将发布	Release on progress

测试工况

蒸发温度	Evaporating temperature	-23.3°C
冷凝温度	Condensing temperature	54.4°C
过冷温度	Subcooling temperature	32.2°C
吸气温度	Suction temperature	32.2°C
环境温度	Ambient temperature	32.2°C

TEST CONDITIONS(ASHRAE)

单位换算 CONVERSION

1 Watt = 3.41 Btu/h = 0.86 kcal/h

型号	电机	排气量	电机类型	频率	制冷量		输入功率	性能系数	启动电容	运行电容	高度	重量	认证
Model	Motor	Displ.	Motor Type	Freq.	Cooling Capacity	Cooling Capacity	Input Power	COP	Start Capacitor	Run Capacitor	Height	Net Weight	Certification
		cm ³		hz	w	kcal/h	w	w/w	μF	μF	mm	kg	
220-240V/50Hz													
中效系列 Medium Efficiency Range													
GTH86AA	Al	8.6	RSCR	50	240	206	163	1.47	-	5	174	9.0	CCC/VDE
GTH93AA	Al	9.3	RSCR	50	260	224	174	1.49	-	5	184	9.7	CCC/VDE
高效系列 High Efficiency Range													
GTT75AA	Cu	7.52	RSCR	50	210	181	134	1.57	-	4	184	10.1	CCC/VDE
GKD86AA	Cu	8.6	RSCR	50	240	206	144	1.66	-	6	184	10.4	CCC/VDE
GKD86AA I	Cu	8.6	RSCR	50	240	206	141	1.70	-	6	184	10.4	CCC/VDE
GKD93AA	Cu	9.3	RSCR	50	270	232	163	1.66	-	6	184	10.4	CCC/VDE
200-220V/50Hz, 220-230V/60Hz													
中效系列 Medium Efficiency Range													
GVY75AG	Al	7.5	RSCR	50	201	173	139	1.45	-	5	184	10.1	CCC/VDE
				60	232	200	157	1.48	-				
高效系列 High Efficiency Range													
GKD86AG*	Cu	8.6	RSCR	50	245	211	163	1.50	-	5	184	10.1	-
				60	280	241	175	1.60	-				
GKD93AG*	Cu	9.3	RSCR	50	290	249	193	1.50	-	5	184	10.1	-
				60	340	292	213	1.60	-				
115V/60Hz													
GVT66AD	Cu	6.6	RSCR	60	217	187	136	1.60	-	10	184	10	UL
GTT75AD	Cu	7.5	RSCR	60	251	216	157	1.60	-	10	184	10	UL
GKD66AD	Cu	6.6	RSCR	60	217	187	125	1.74	-	10	184	10	-
GKD75AD	Cu	7.5	RSCR	60	257	221	148	1.74	-	10	184	10	UL
GTM93AD	Cu	9.3	CSIR	60	305	262	226	1.35	50	-	184	10	UL
160-260V/50Hz													
超低电压启动系列 Low Start Voltage Range													
GVY57AA	Al	5.7	RSCR	50	160	138	113	1.42	-	4	174	8.8	CCC/VDE
GVY61AA	Al	6.1	RSCR	50	170	146	113	1.51	-	4	174	9.4	CCC/VDE
GVY66AA	Al	6.6	RSCR	50	180	155	124	1.45	-	4	174	8.6	CCC/VDE
GVY75AA	Al	7.5	RSCR	50	200	172	140	1.43	-	4	174	8.9	CCC/VDE

注 NOTE

冷却方式	Cooling Type
静态冷却	Static Cooling
应用条件	Application
低背压	LBP
*即将发布	Release on progress

测试工况

蒸发温度	Evaporating temperature	-23.3°C
冷凝温度	Condensing temperature	54.4°C
过冷温度	Subcooling temperature	32.2°C
吸气温度	Suction temperature	32.2°C
环境温度	Ambient temperature	32.2°C

TEST CONDITIONS(ASHRAE)

单位换算 CONVERSION

1 Watt = 3.41 Btu/h = 0.86 kcal/h

Outline drawings 外形尺寸

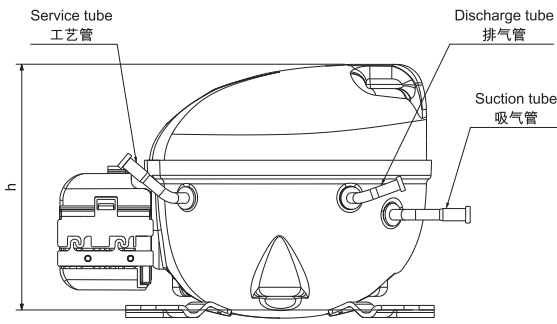

主视图

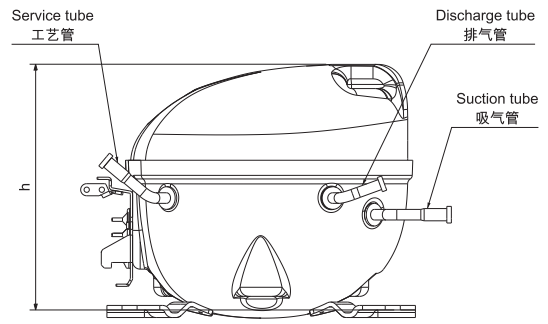

主视图

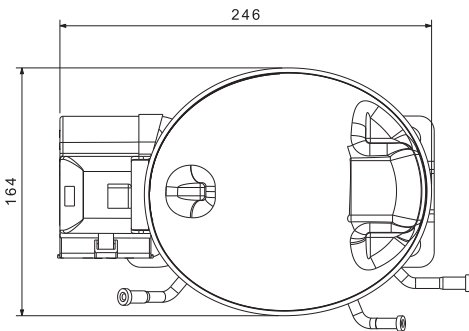

俯视图

H*Z
Standard Version
通用款

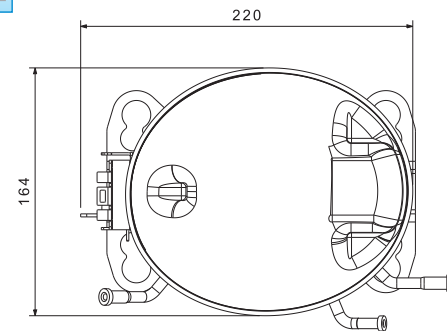

俯视图

H*Z
For USA and Japan
北美/日本款

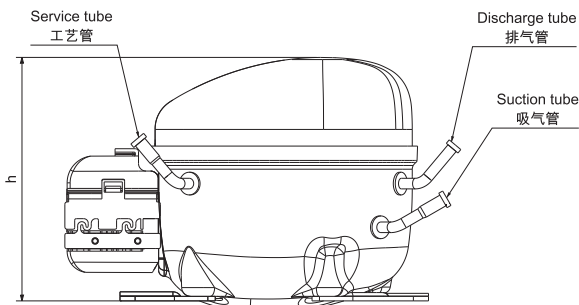

主视图

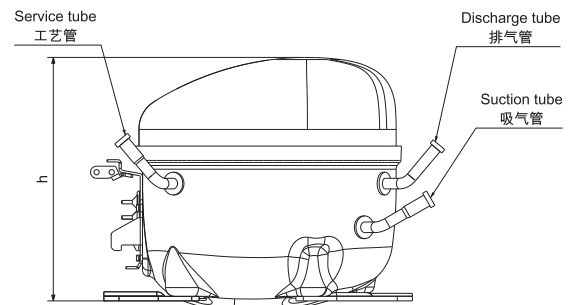

主视图

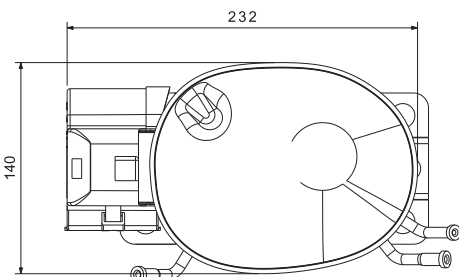

俯视图

H*L-G*L
Standard Version
通用款

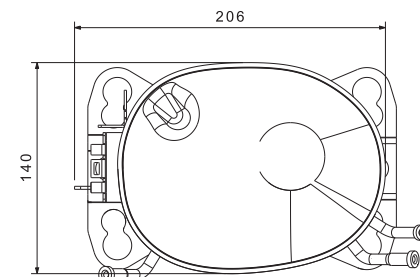

俯视图

H*L-G*L
For USA and Japan
北美/日本款

Outline drawings 外形尺寸

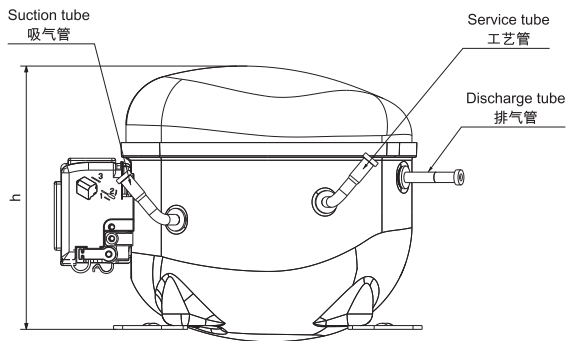

主视图

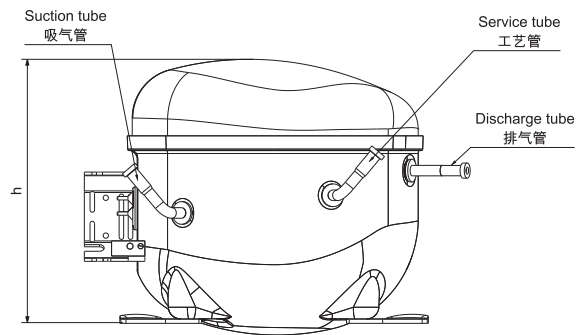

主视图

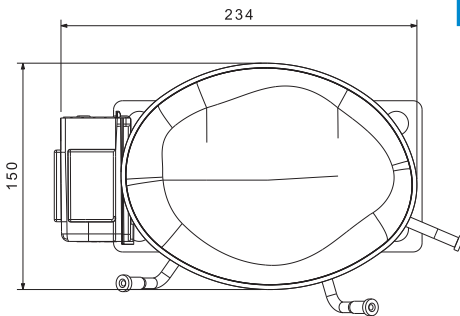

俯视图

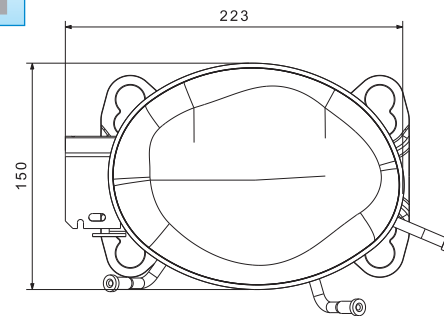

俯视图

OF-GV-GT-GK-HV-HT-HPK
Standard Version
通用款

OF-GV-GT-GK-HT
For USA and Japan
北美/日本款

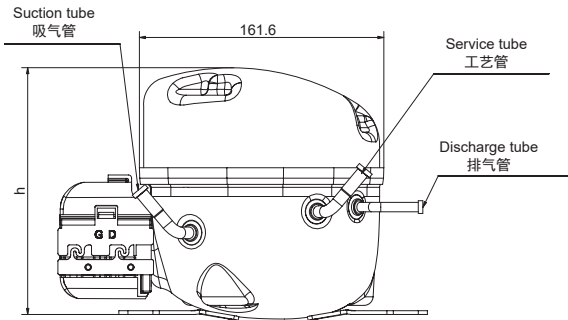

主视图

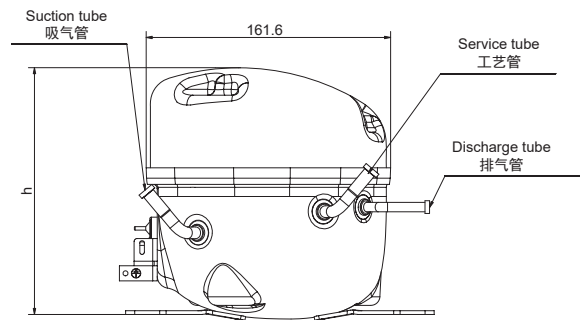

主视图

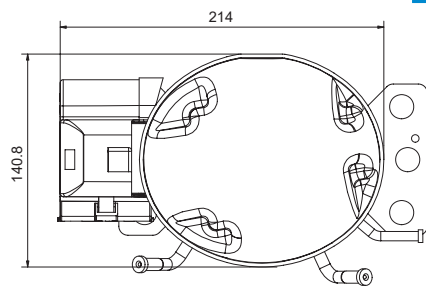

俯视图

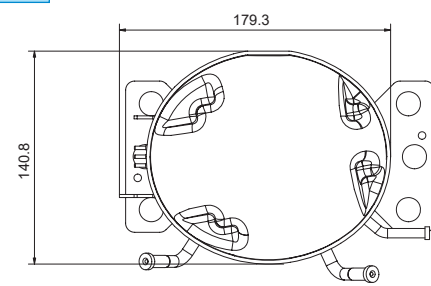

俯视图

H*M
Standard Version
通用款

H*M
For USA and Japan
北美/日本款

Outline drawings 外形尺寸



Variable Speed Range
变频系列

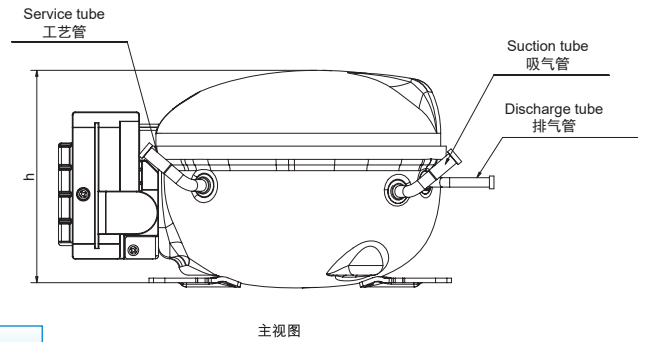
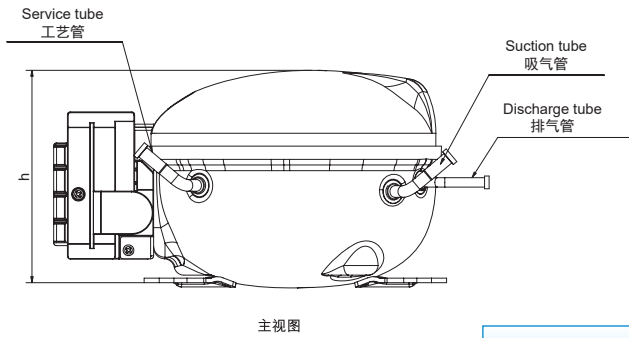

Z Series VSC

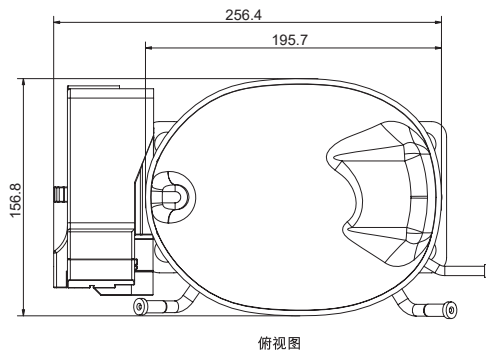

H*Z
Standard Version
通用款

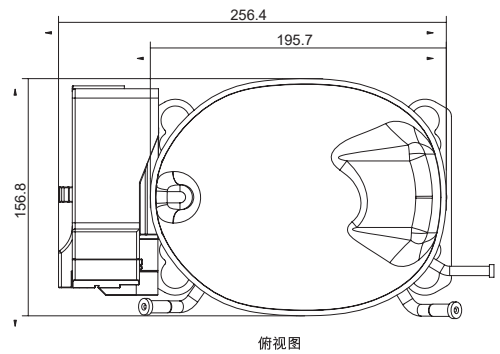

H*Z
For USA and Japan
北美/日本款

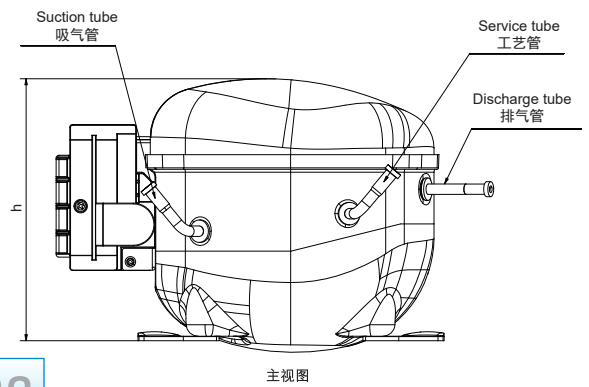
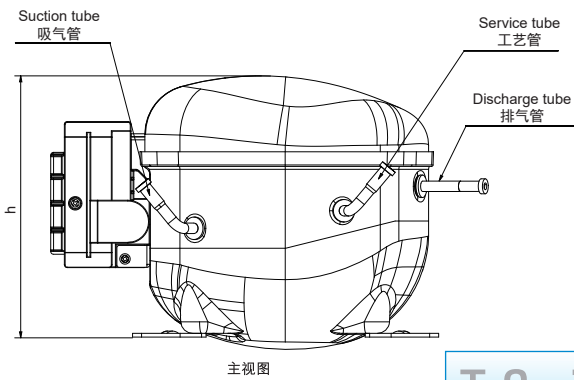

T Series VSC

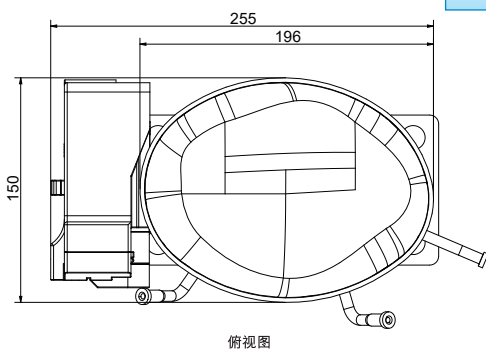

HKD-GKD-NKD
Standard Version
通用款

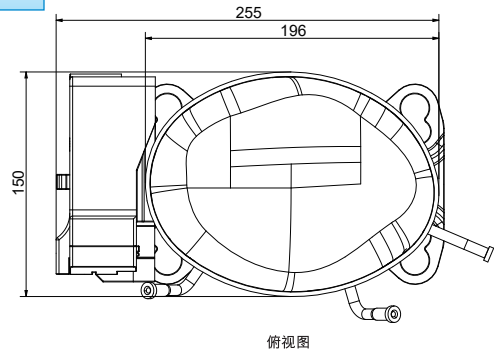

HKD-GKD-NKD
For USA and Japan
北美/日本款

Electric wiring diagram 电气接线图

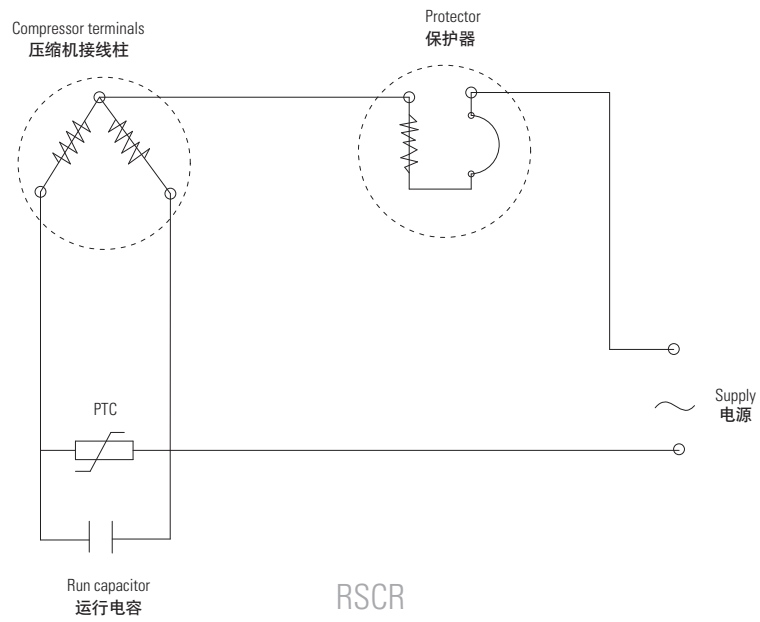
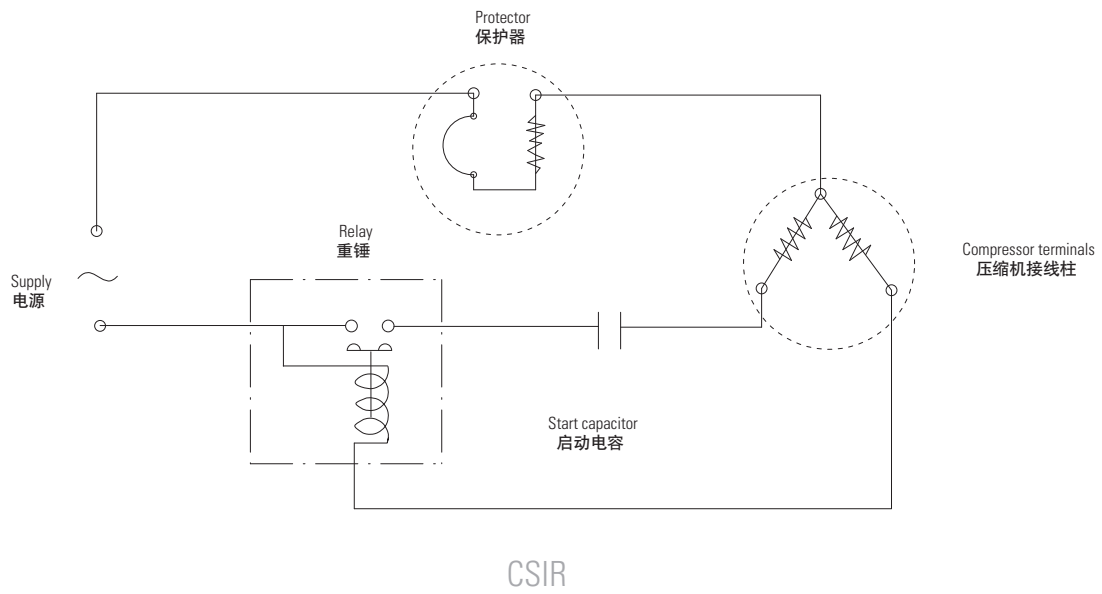

Electric wiring diagram 电气接线图

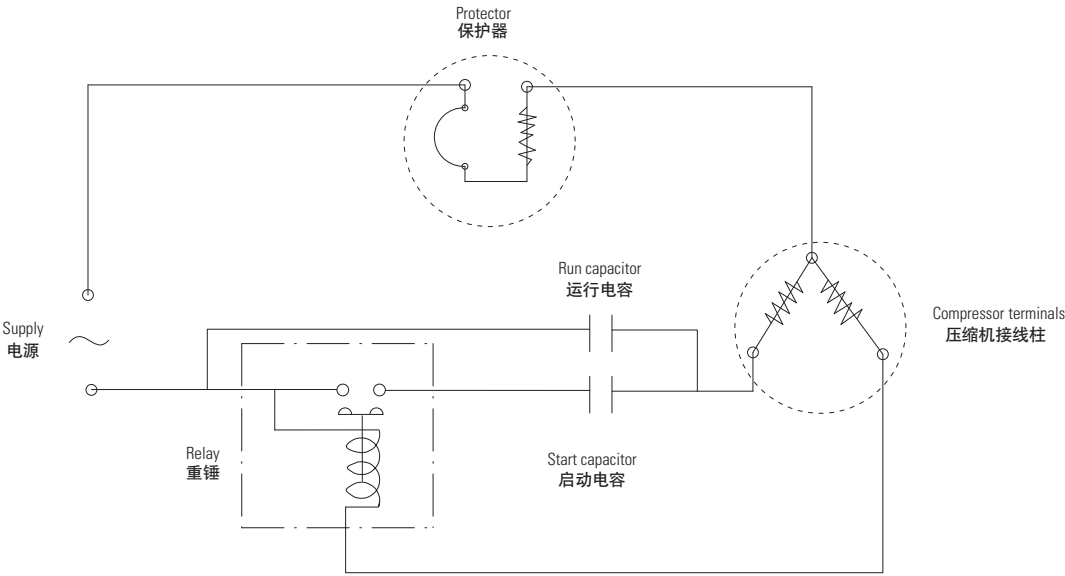

CSCR

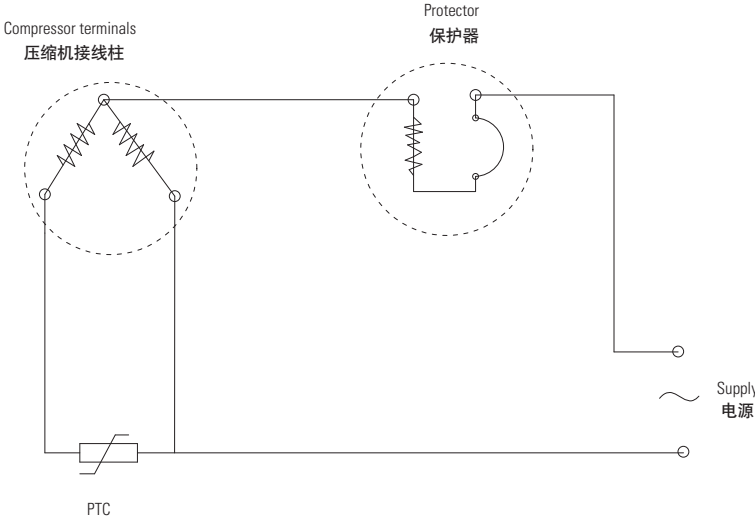

RSIR

Mounting accessories

底脚附件连接示意图

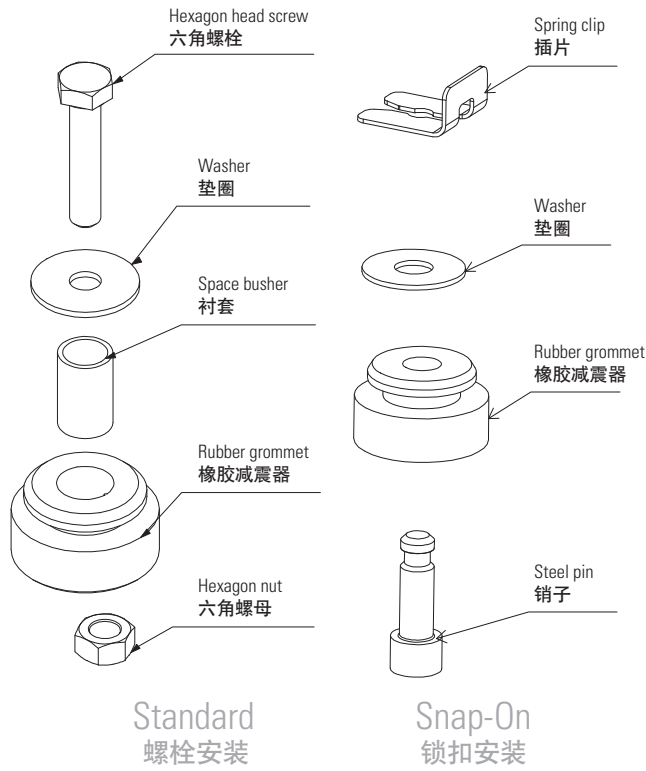

Electrical Components Assembly

电气附件安装

Lambda/Zeta/Micro

GD

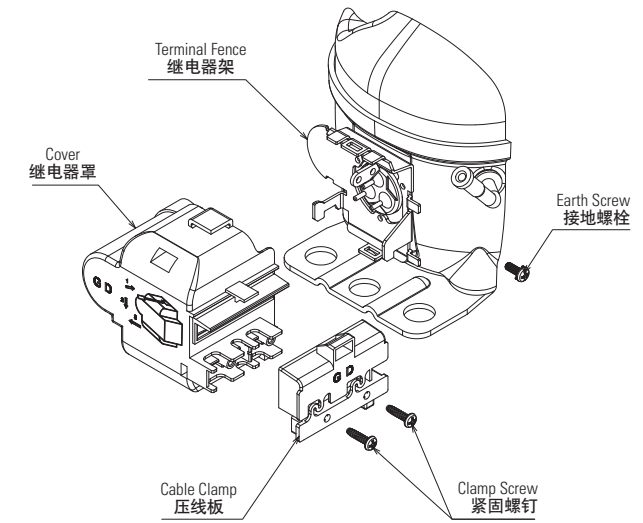

GD-3

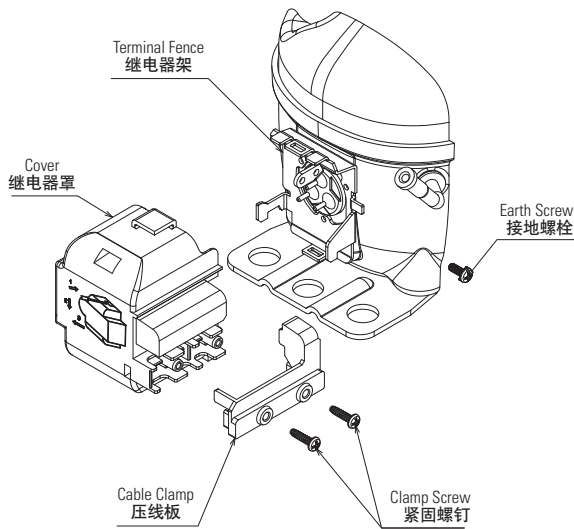

GDI

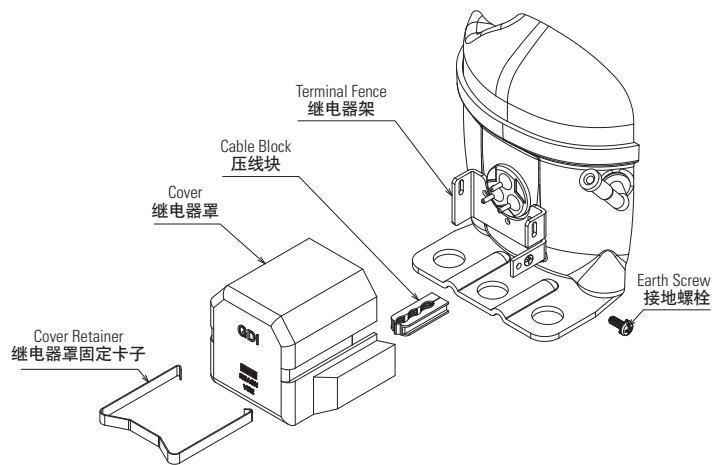

Electrical Components Assembly 电气附件安装

Lambda/Zeta/Micro

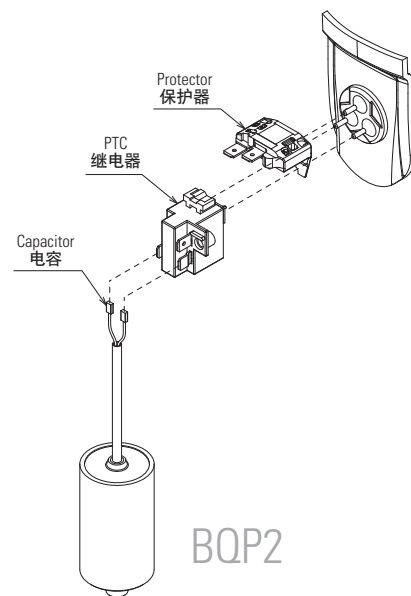
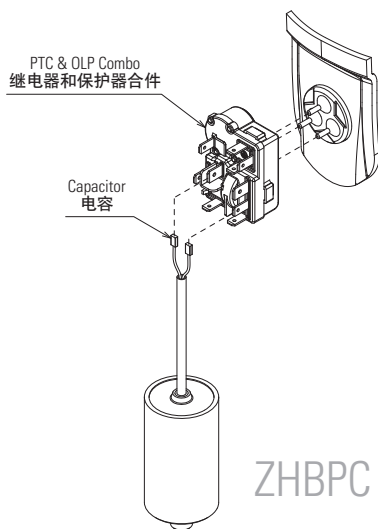
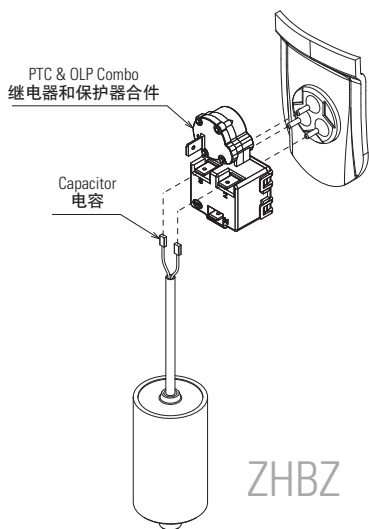
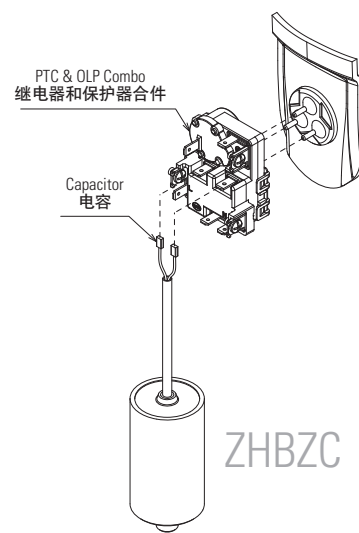
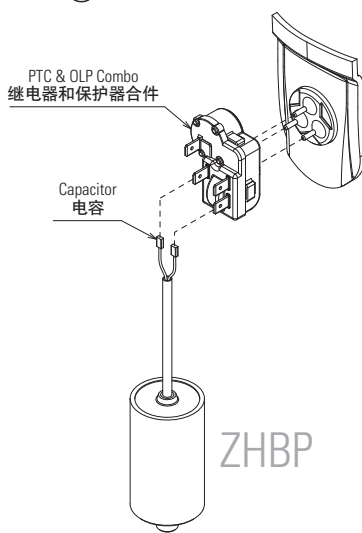
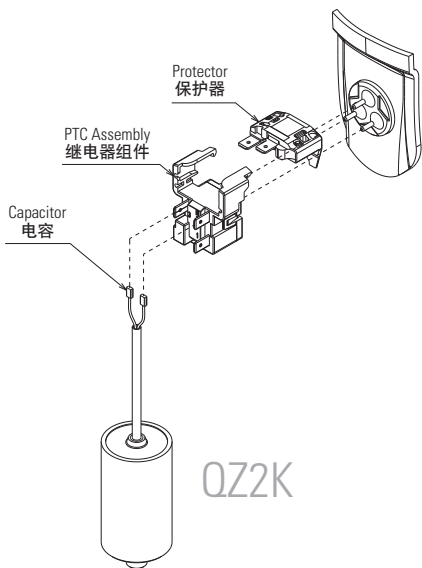
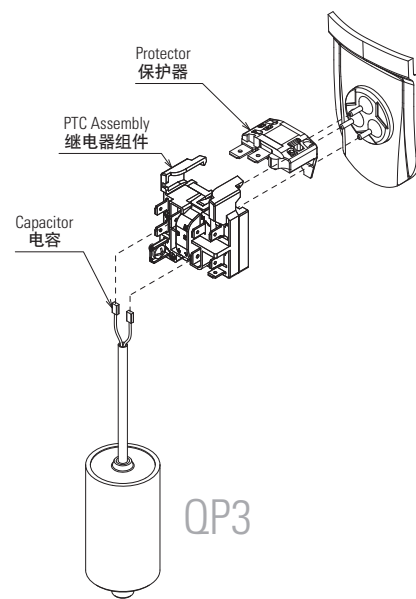
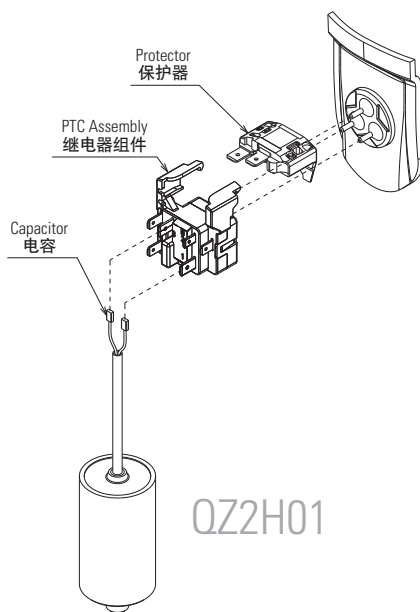
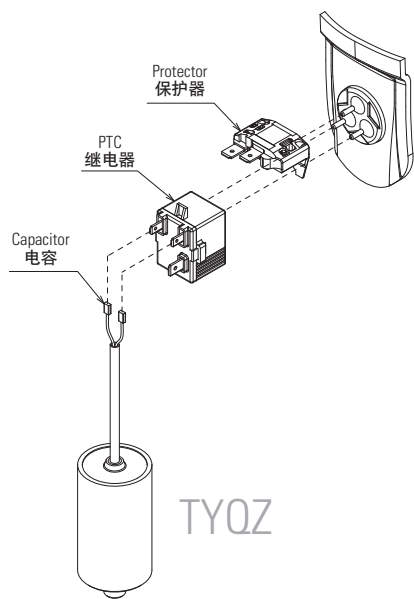

Electrical Components Assembly 电气附件安装

Tau

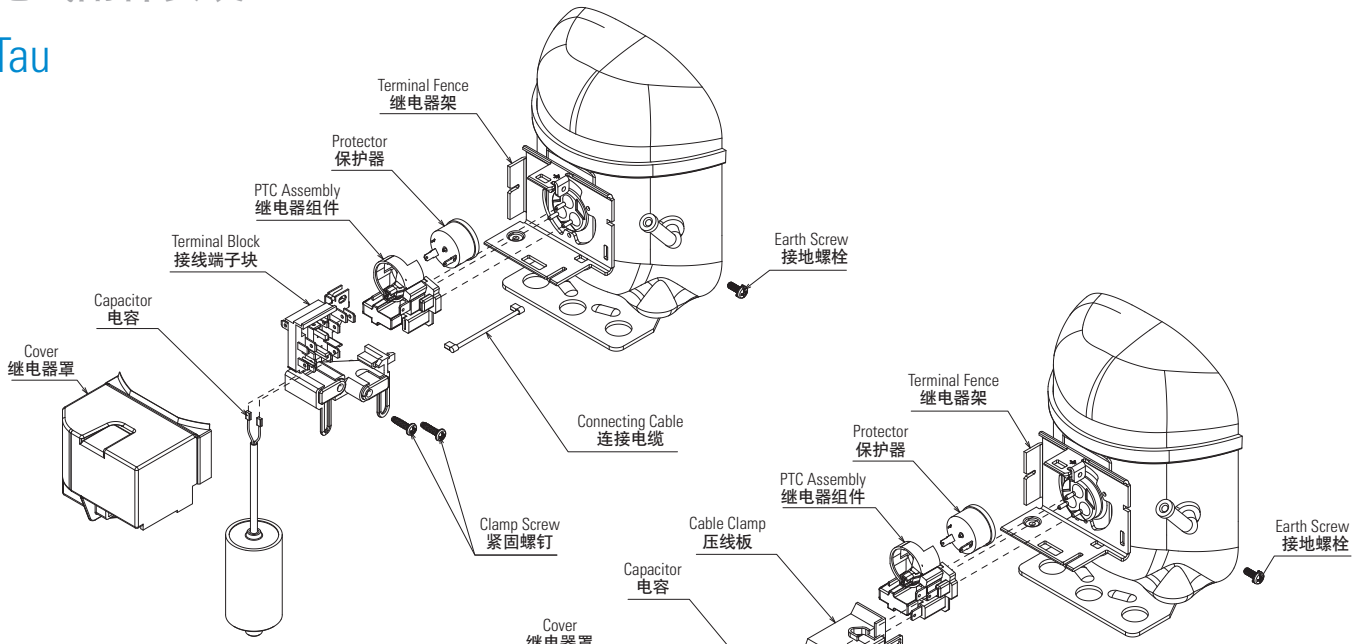

ZEM2 MOD90

ZEM2 MOD91

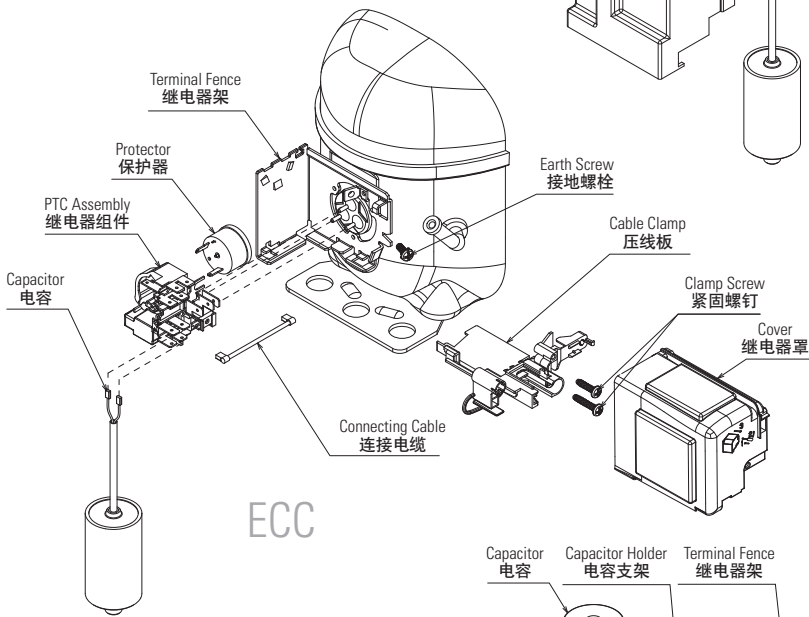

ECC

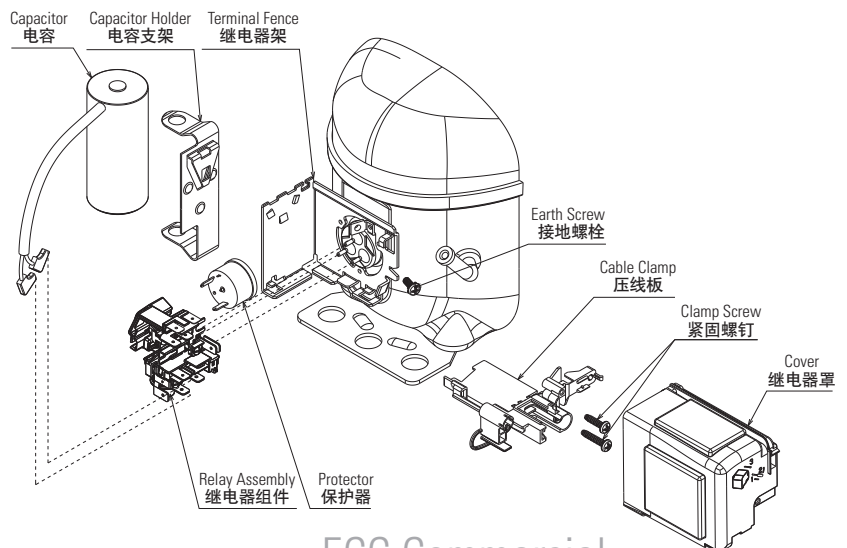

ECC Commercial

Electrical Components Assembly 电气附件安装

Tau

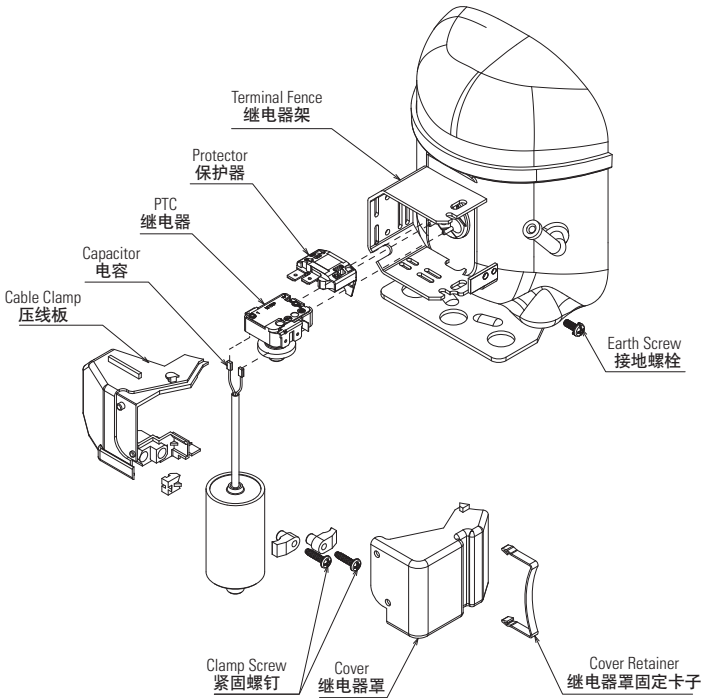
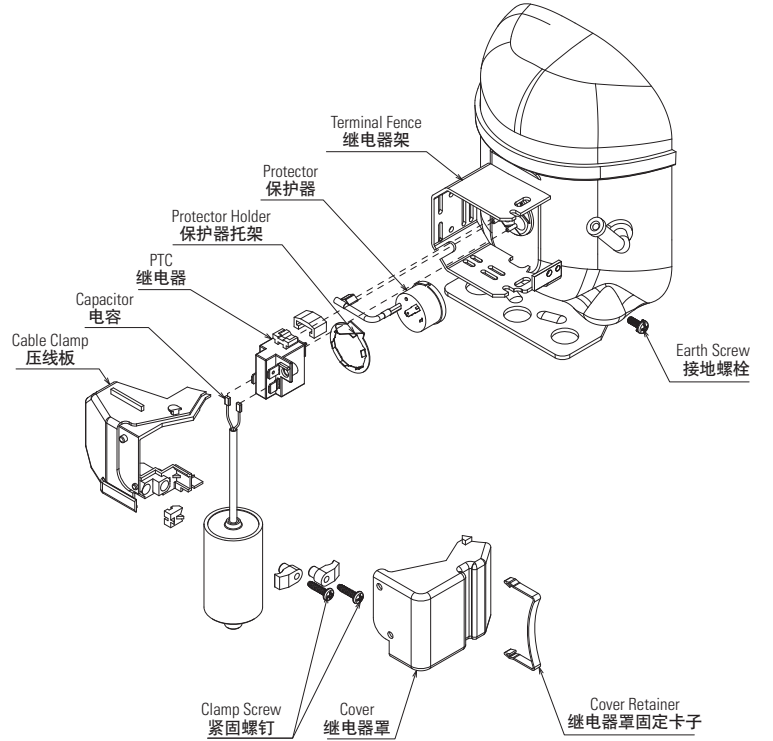
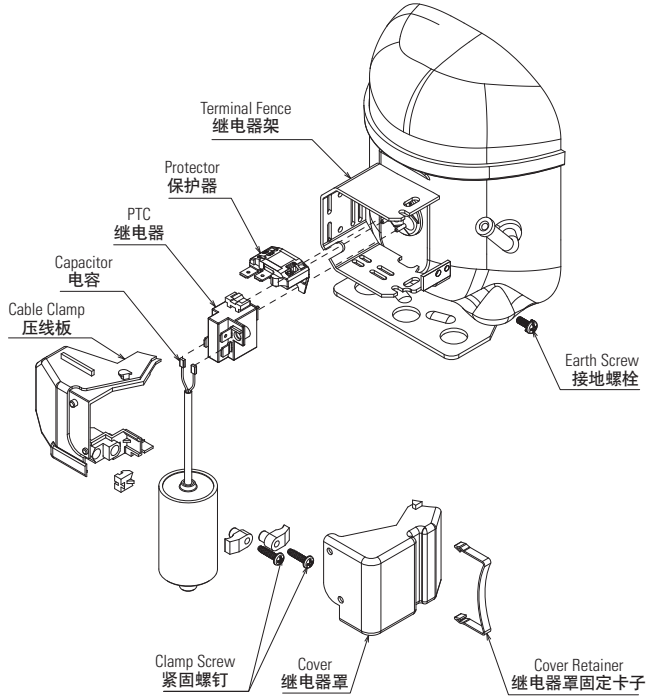

UH

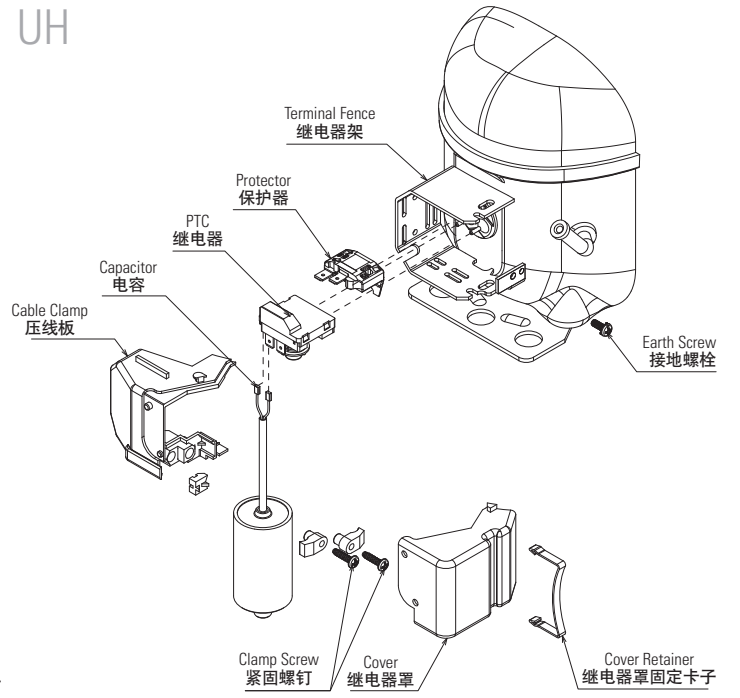

Packaging 包装

Tau

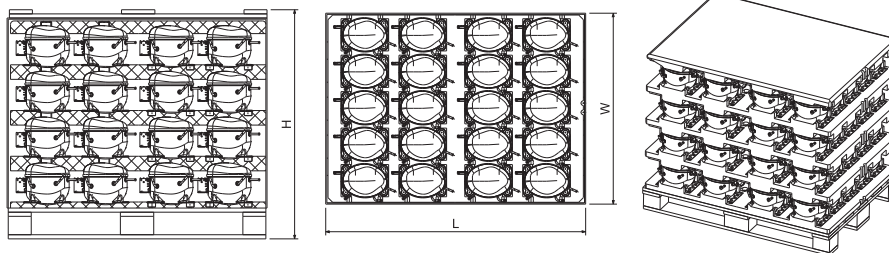

Lambda

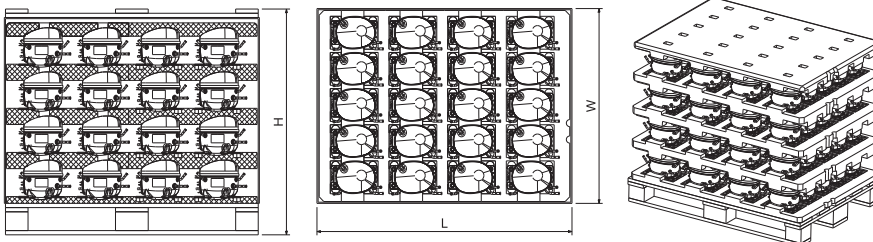

Zeta

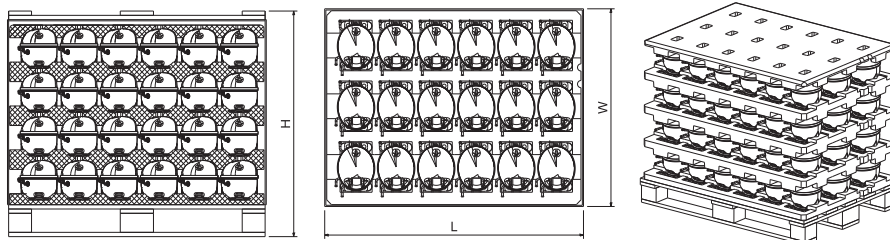

Micro

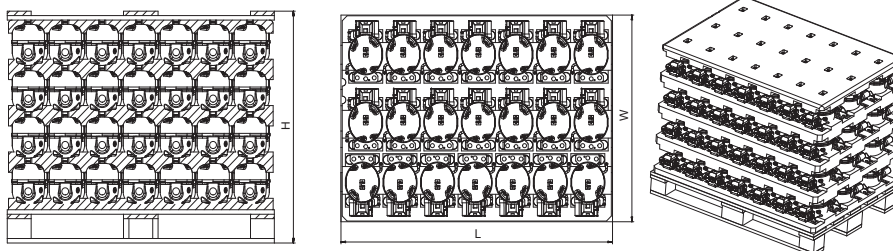

Z Series VSC

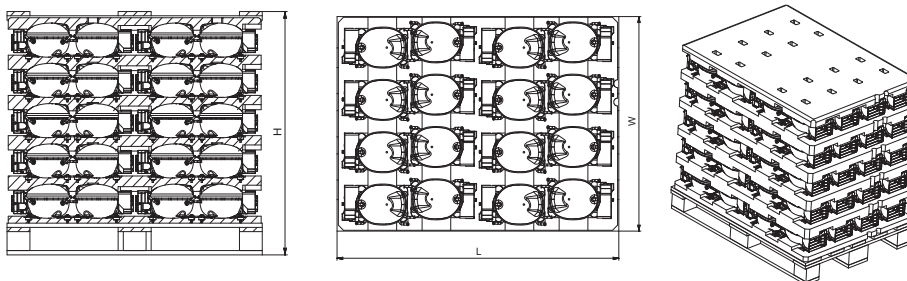

系列 Series	包装数量 (台/包) Quantity (pcs/pallet)	包装外形尺寸(长×宽×高) Outline dimensions (L×W×H)	适用领域 Applicable domain	备注 Notes	20尺集装箱装载数量 Qty in 20' Container
Tau	80	1120×840×955/1000/1040	出口 Export	4层 4Layers	2,240/2,160
	100	1120×840×1150/1200/1250	国内 Domestic	5层 5Layers	
LAMBDA	80/92	1120×840×930/960	出口 Export	4层 4Layers	2,240/2,576
	100/115	1120×840×1100/1150	国内 Domestic	5层 5Layers	
Zeta	72	1120×840×960	出口 Export	4层 4Layers	2,016
	90	1120×840×1150	国内 Domestic	5层 5Layers	
Micro	84	1120×840×930/960	出口 Export	4层 4Layers	2,352
	105	1120×840×1100/1150	国内 Domestic	5层 5Layers	
Z Series VSC	80	1120×840×1050	出口 Export	5层 5Layers	2,160
	96	1120×840×1220	国内 Domestic	6层 6Layers	



扎努西电气机械天津压缩机有限公司

中国天津港保税区(空港)保税路3号

电话:+86 22 84861686

传真:+86 22 84861687

邮箱:sales@zeltj.com

ZANUSSI ELETTROMECCANICA TIANJIN COMPRESSOR CO.,LTD

ADDRESS: NO.3 BAOSHUI ROAD, TIANJIN PORT FREE TRADE ZONE
(AIRPORT INDUSTRIAL PARK), TIANJIN CITY,PR CHINA

ZIP CODE: 300308

PHONE: +86 22 84861686

FAX: +86 22 84861687