

Document No : 20110727

R134a

# **SPECIFICATIONS for APPROVAL**

MODEL :**MA72LBJG (OC)\_CUPRO**

<b>Customer</b>	APPROVED	
	Date of Approval	
	Signature	
	Remarks	

<b>Supplier</b>	Date of Issue	July,27,2011
	Sales Manager	SRIHARI KANDRA
	Design Manager	GAURAV KOCHHAR

**Refrigeration compressor, LG Electronics Inc.**

Tele: (+91) 120 - 2560 900, Fax: (+91) 120 – 2560 921

\*\* Pls Return one copy on your Approval

**- CUSTOMER : CUPRO**  
**- MODEL : MA72LBJG(OC)**  
**- RATED VOLTAGE / FREQUENCY : 220V/50Hz**  
**-SPEC. NO. : 20110727**

TO : LG ELECTRONICS COMP.EXPORT DEPT.  
 ATTN :  
 FAX : +91-120-2560-921  
 FROM : DATE : 27<sup>th</sup> July. 2011

PREPARED	CHECKED	APPROVED
Saurab	N. Sathya	G. Kochhar

**PARTS LIST**

PART LIST		LGE SUPPLY	LG PART NO	Q'TY	MODEL / SPECIFICATION
COMPRESSOR	PERFORMANCE				
COMPRESSOR	WIRING DIAGRAM				
COMPRESSOR	EXPLODED VIEW				
ELECTRICAL PARTS	OLP	√	6750CN0004T	1	4TM232TFB
ELECTRICAL PARTS	STARTING DEVICE	√	6748C-0003C	1	P330MC
ELECTRICAL PARTS	COVER	√	3550CN0011A / 3550JF2008B	1	Cover ,PTC
COMP MOUNTING	MOUNTING ASSEMBLY				
COMP MOUNTING	SEAT RUBBER	√	5166CN0001A	4	Grommets
COMP MOUNTING	BOLT,HEXAGON HEAD,M COARSE 1	√	1BHD2650682	4	Mounting Bolts ( OD 26.5 / ID 6.5 mm SCM3 / BK)
COMP MOUNTING	WASHER,PLAIN	√	1WPZ0010001	4	A TYPE D25.2 A1070BR
COMP MOUNTING	WASHER,SPRING LOCK	√	1WSV0550014	4	

\* CUSTOMER'S MEMO \*

CUSTOMER'S DECISION

Decision : Yes , No

Signature :

\* Please return one copy of this page on your approval.

## **RESULT OF CHECK FOR CUSTOMER**

### **1. SPECIFICATION OF CABINET**

No	Items	Result	No	Items	Result
1	Model Name		5	Charging quantity	000 grams
2	Cooling Type	Direct , Indirect	6	Current Comp. Model	
3	Nominal Capacity	000 Litter	7	Starting device	PTC , Relay
4	Refrigerant	R12, R134a, R600a	8	Starting Type	

### **2. SET MATCHING**

No	Evaluation items	Result (Data)	Remark
1	Startability : Be satisfied ?		
2	Energy consumption : Be satisfied ?		
3	Noise : Be satisfied ?		
4	Application is satisfied ?		
5	Shipping Test : Be satisfied?		
6	Etc. Mounting is satisfied ?		

\*Please check the item, if you don't need evaluation item.

### **3. RELIABILITY**

No	Evaluation items	Result (Data)	Remark
1	What is the evaluation item for reliability?		
2	Would you agree as the result ?		

\*\*Please return one copy on your approval.

# Performance & Dimension

## Application

Type	Low Back Pressure
Evaporating Temp. Range	-30 °C to -5 °C
Refrigerant	R134a
Refrigerant control	Capillary tube
Compressor cooling	Static

## Normal Performance (ASHRAE) 50Hz

Capacity Watt - 7%	209
Kcal/h -7%	180
BTU/h -7%	715
Power consumption (Watts) + 7 %	162
Cop W/W -7%	1.3
EER BTU/wh -7%	4.4
NOISE dBA	42(Max)

## Testing conditions

Evaporating Temp	-23.3 °C (-10 °F)
Condensing Temp	54.4 °C (130 °F)
Ambient Temp	32.2 °C ( 90 °F)
Return Gas Temp	32.2 °C ( 90 °F)
Liquid Temp	32.2 °C ( 90 °F)
Running Voltage	220V / 50Hz

## Compressor Data

Design	Reciprocating
Displacement	7.22 cc/rev

Suction Tube I.D	6.54mm X 0.7t
Process Tube I.D	6.54mm X 0.7t
Discharge Tube I.D	5.0mm X 0.85t
Oil Cooling Tube I.D	4.95mm X 0.7t

Weight(with Oil charge)	9.2 Kg
-------------------------	--------

## Motor Data

Motor type	RSIR
Motor protection	External protection
Winding Insulation Class	E Class

## Exploded View

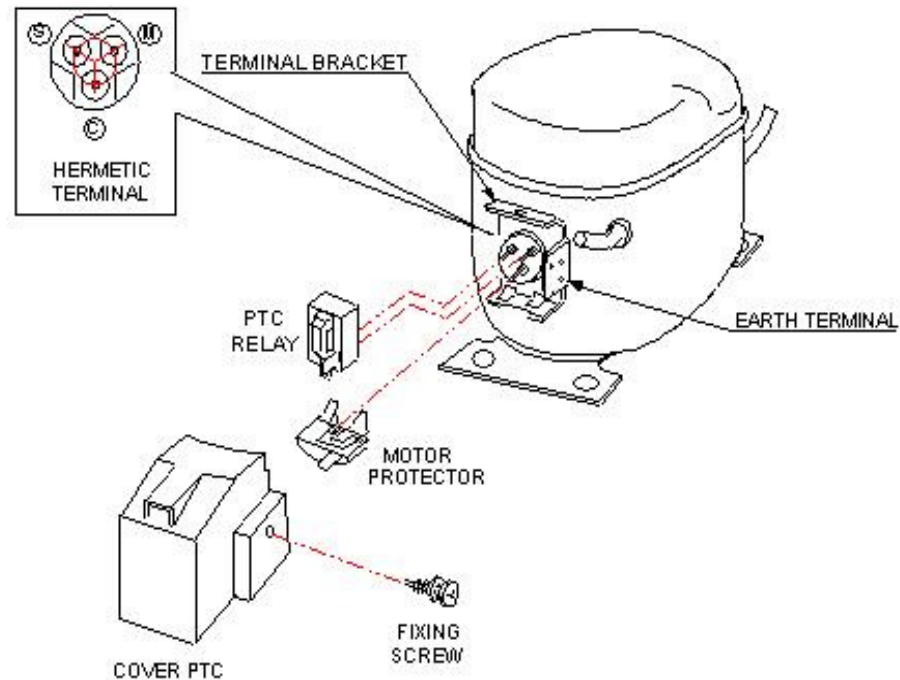

Title	Exploded View
Dwg. No	EXP-PTJS14TM01X



## Dimensional Details

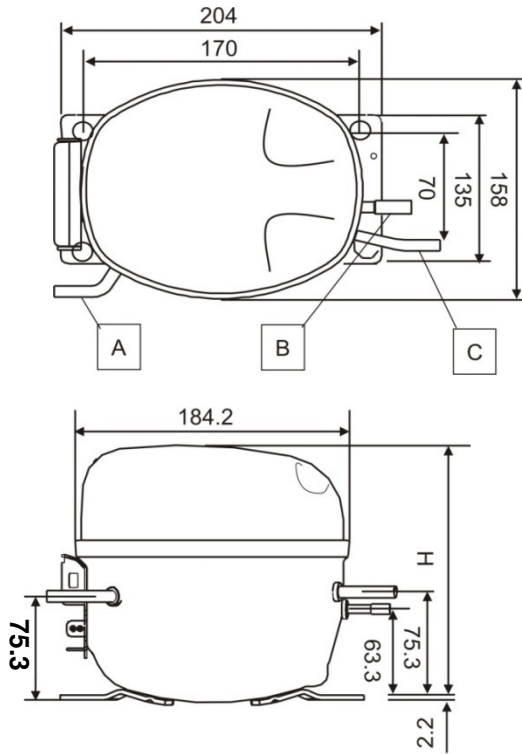

## Ear Mounting

Type A

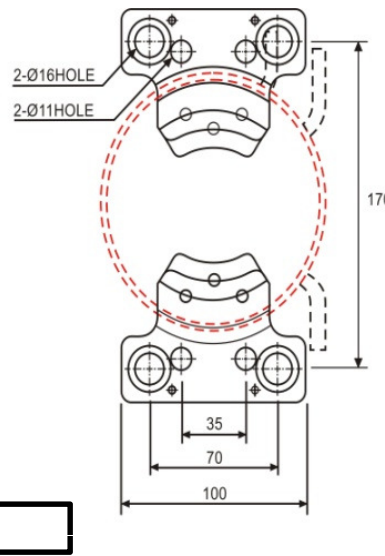

Type B

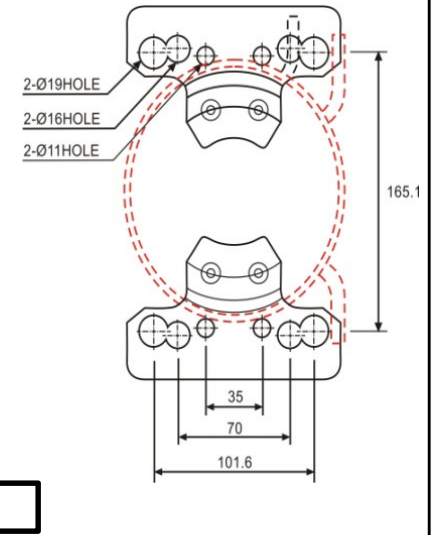

Note : Customer has to select Mounting Put Tick on above block as per the mounting type preference.

## Oil Cooling Details

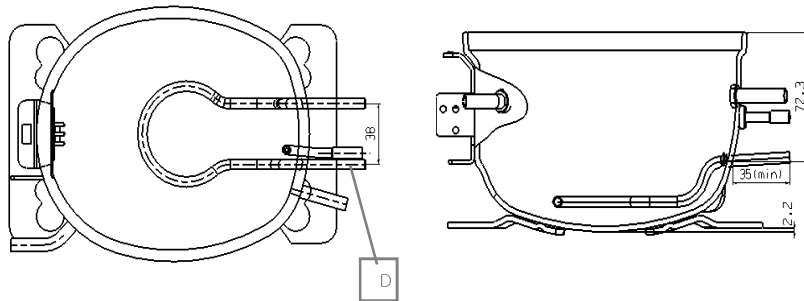

## Dimensional Details

Series	H mm	A		B		C		D	
		Suction		Discharge		Process		Oil Cooling	
		ID (mm)	T(mm)	ID(mm)	T(mm)	ID(mm)	T(mm)	ID(mm)	T(mm)
MA42/45/53	172	6.54	0.7	5	0.85	6.54	0.7	NA	NA
MA57/62/69/72/88	180	6.54	0.7	5	0.85	6.54	0.7	4.95	0.7
MC53/57/62 MQ88/98	180	6.54	0.7	5	0.85	6.54	0.7	NA	NA

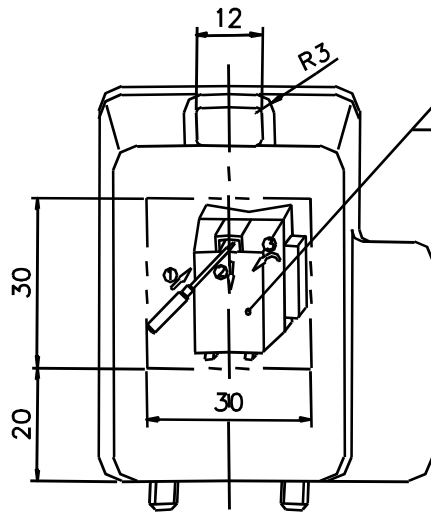
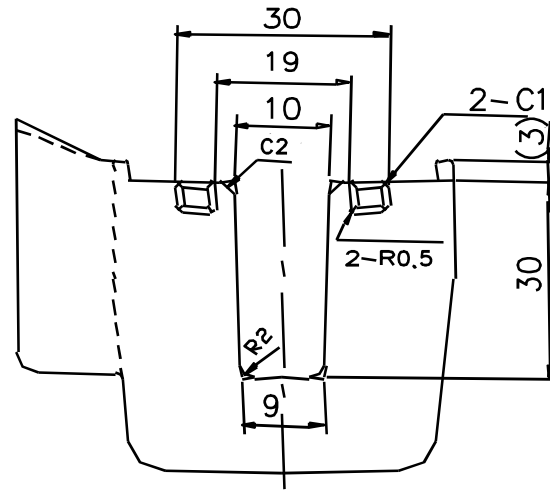
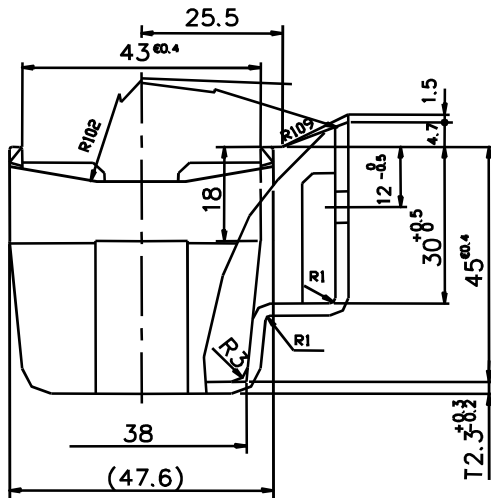

SHAPE: RELIEF  
HEIGHT AND WIDTH: 0.3\*0.3

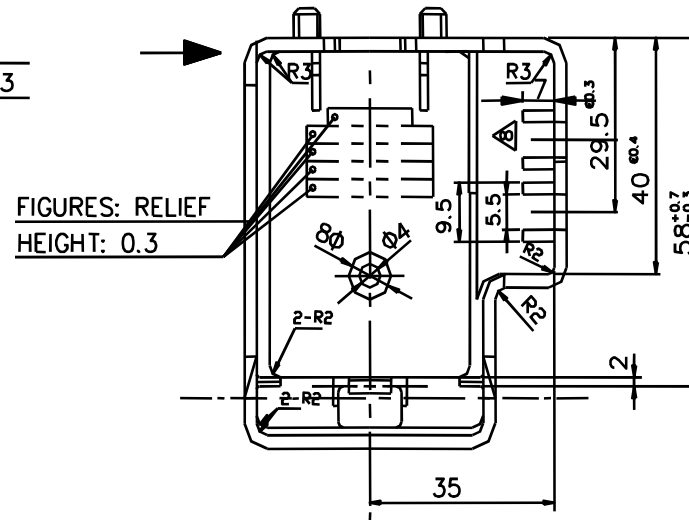

FIGURES: RELIEF  
HEIGHT: 0.3

Title	COVER PTC
PART. No	3550CN0011A/3550C-0054A





# TECHNICAL BULLETIN : Application Specification for R134a

The life time of a compressor used in appliance is not only affected by the durability of compressor, but also depends upon the operating conditions imposed on it by design on the refrigeration system it is used in.

This bulletin covers the specification and usage limits for LG R134a low back pressure (LBP) compressor.

The limits and guidelines set forth in this publication should be observed.

## Pressures and temperatures

At ambient temp 43 °C

Condition	Normal operation		Peak conditions at maximum load (at initial pull-down) (Area "A", "B" and "C" on chart)
	Stabilized condition (Area "A" on chart)	Transition running (Area "A" and "B" on chart)	
Discharge Pressure	17.1kgf/cm <sup>2</sup> abs (equal to condensing temp. of 60 °C)		21.6kgf/cm <sup>2</sup> abs (equal to condensing temp. of 70 °C)
Suction Pressure	0.68 to 2.49kgf/cm <sup>2</sup> abs (equal to evap. temp. of -35 °C to -5 °C)		0.68 to 7.0kgf/cm <sup>2</sup> abs
Motor Winding Temp. "D-Tube" Temp.	Under 120 °C 1*(NR/M* / L* ) : Under 110 °C, 2*(NS*/TS) : 120 °C		Under 130 °C 1* / 2* : Under 120 °C / 130 °C

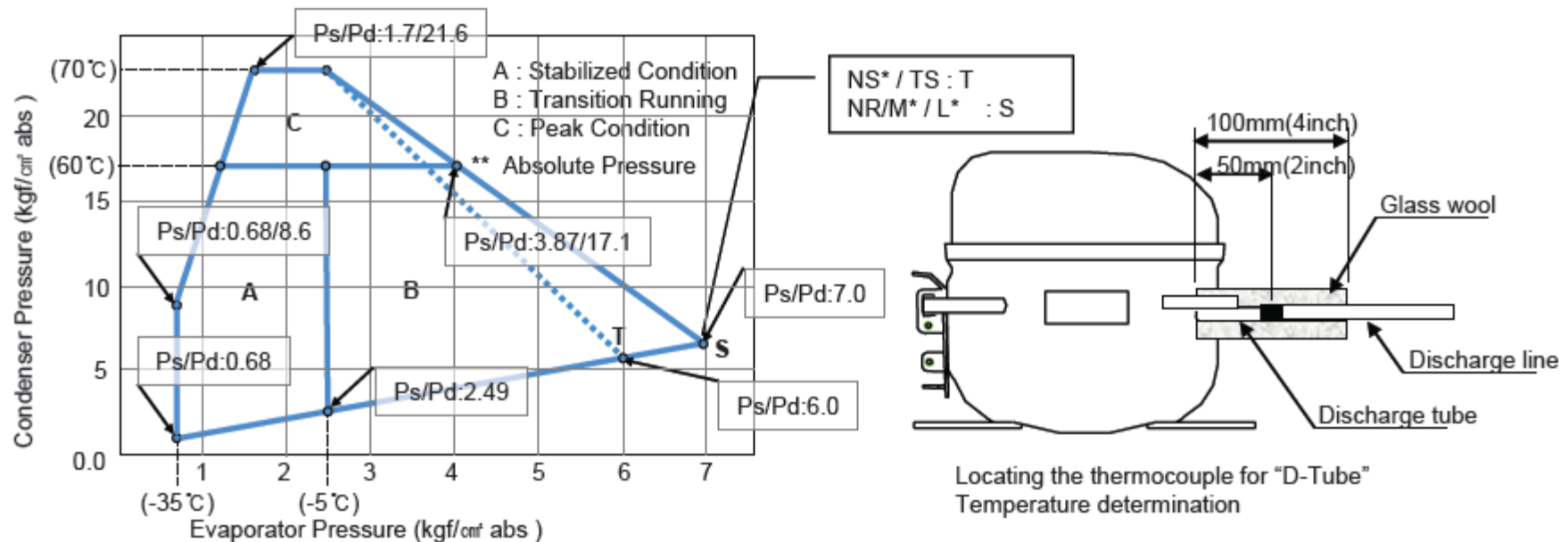

## **TECHNICAL BULLETIN : Application Specification for R134a**

No	Item	Standard & Designation	Conditions & Remark
1	Refrigerant	R134a	-
2	Ambient temp.	-5 ~ 43 °C	Operating ambient temperature should be kept
3	Evaporation temp.	L,B,P : -35 ~ -5 °C(-31~23 °F)	Except for the short period such as pull-down tec.
4	Condensing temp.	60 °C(140 °F) max, 70 °C(158 °F) max.	In stabilized at ambient temp. 43 °C(110 °F),At the peak in pull-down in ambient temp. 43 °C(110 °F)
5	Equalized pressure at starting	Equalized pressure : •NS* / TS : 6.0kgf/cm <sup>2</sup> abs or less •M* / L* : 7.0kgf/cm <sup>2</sup> abs or less	Cabinet startability should be confirmed for a compressor dome temperature greater than 65 °C •Shell temperature : -5 to 65 °C •If exceed, must be verified the startability with set test.
6	Voltage range	-15% ~ +15% * rating	At the terminals of compressor
7	Cycle time	On time : 5 minutes or more Off time : 5 minutes or more	Recommended to start up at balanced Hi-Lo Pressures in 5 minutes after stand still.
8	Refrigerant charge	Minimal	Minimize meeting cooling performance, startability, temperature limits, pressures limits, pressures limits
9	Evacuation levels	0,5 Torr max.	Evacuation should be done from both the high and low sides
10	Oil Moisture	25 ppm max.	-
11	System Moisture	150mg max.	In a refrigeration system, due to degradation of ester oil caused by moisture
12	Pressure rise at abnormal situation	35kgf/cm <sup>2</sup> abs max.	Even in case of condenser fan-blocked.
13	Non-condensable gas	Total : 1%(Vol.) Max. Oxygen : 0.01%(Vol.) Max.	Against total inner volume of refrigeration system.
14	Degree of tilt	5 deg. Max.	On running. Compressor shall not be tilted more than 5 degrees in all direction.

## **TECHNICAL BULLETIN : Application Specification for R134a**

### **Note :**

1. Do not leave the Compressor with it's pinch plug open for more than about 15 minutes.
2. Purchased compressor with oil charged and sealed be used within 6 months from the production date shown on the name plate.
3. Never run the Compressor with any air other than the refrigerant.
4. Never run the Compressor without refrigerant properly filled inside.
5. A dropped Compressor must not be used.
6. To avoid any contamination on the refrigerator assembly line, a dedicated charging station (refrigerant or oil) must be used
7. All materials used in the process must be compatible with the R134a.
8. The system components must have a degree of cleanliness better than that of R12 system.  
Especially residue of chlorinated impurity shall not be allowed.
9. Special dryer is needed when using .(for instance XH-7 or XH-9), Usually a 20% larger dryer is recommended.

### **10. Electrical accessories**

\*The compressor's electrical accessories should be used within specification and within their permissible ambient temperature

\*Vinyl chloride and chloride compounds should not be used as a material for electrical terminal covers and electrical connections.

- 11. Brazing** - Compatible materials and proper brazing techniques must be used to assure complete unoxidized joints, and to avoid flux, particles or dust from entering the sealed systems.

### **12. Motor protector**

All accidents can not be prevented by motor protectors. An earth terminal should be installed to prevent electrical accidents caused by the following factors.

- wrong power source, - Wrong wiring , - Wrong electrical parts
- Operation in a system leak - Operation under a vacuum condition, - Abnormal parts, Lightning damage

### **13. Liquid back**

Excessive liquid back in refrigeration system should be avoided to prevent an abnormal wear at a friction area by a cause of a lubrication malfunction. In addition, liquid back can cause damage to the crank shaft, calve plate and head gaskets, causing them to break.

14. In case of change in cycle construction or parts related to compressor or compressor specification without agreement of LGE. Please notify that the responsibility for all case of problem issues is to the customer.



**CAUTION** : Please install the refrigerant / lubricant oil / electrical component recommended by compressor manufacturer. For. Proper wiring, please follow manufacturer's instructions exactly for prevent exploding, firing and user being shocked by Electric. This caution has to be informed end-user and professional SVC branch systemically.



**Electrical shock hazard**

- Compressor must be grounded whenever power is applied and compressor is operated.
- Turn off the power in advance of servicing.
- Secure retain terminal cover whenever power is applied to the compressor.



**Explosion or Fire**

- Remove refrigerant securely from compressor in case of welding.
- Do not compress air or operate compressor with vacuumed inside
- Wear safety goggles and gears.



**Getting burnt**

- Do not touch the compressor with bare hands during operation or after stoppage instantly.

3-1.Materials compatible to R134a should be used in refrigeration system

3-2.Equipments for refrigerant charging and vacuuming exclusively designed for R134a application should be need.

In order not to mix-up other refrigerants such as R12 with R134a, charging equipment exclusively designed for R134a application must be prepared separately. Proper quantity of refrigerant must be determined in advance of charging due to R134a can be charged 20% less than R12 according to refrigeration cycle.

3-3.Leakage test equipment exclusively designed for R134a application should be prepared separately.

3-4.Cleanness of the each components of refrigeration system be kept higher than the cleanness level of R12 system.

(It is recommended the total allowable cleanness shall be kept less than 50% of that of R12 System)

3-5.Maximum water content in refrigeration system must not exceed 150mg.

As molecular sieve, drier exclusively used to R134a such as XH-7 or XH-9 be prepared separately.

Excessive water content generates acid or sludge in the system that can cause blockage in capillary tube.

3-6.When compressor is attached to refrigeration system, give attention to the following notices.

1) Nitrogen is charged and sealed before compressor is shipped.

A compressor should be handled carefully not to be unplugged or damage sealing caps during transportation or in warehouse.

2) Compressor with rubber cap removed must be attached to the cycle as soon as possible.

3) Purchased compressor with oil charged and sealed be used within 6 months from the production date shown on the name plate.

4) During deposition or transportation, keep compressors in upright position and be cautious notto drop it.

5) When compressor is attached to cycle, clean and ventilate the vicinity so that pollutants such as dust, steel tip or flux are not included.

6) Since the paint of compressor is made of epoxy polyamide resin, when the paint peels off, by accident repaint it .

3-7.In case of change in cycle construction or parts related to compressor or compressor specification without agreement of LGE, please notify that the responsibility for all case of problem issues is to the customer.