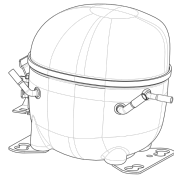

220-240V 50 1~**GENERAL DATA**

Application: LBP
Refrigerant: R134a
Evaporating Temperature Range: -30°C to -5°C
Compressor Cooling: Static
Type: Hermetic reciprocating
Technology Type: On-Off
Expansion Device: Capillary Tube
Packing Quantity: Single - 1 pc
Displacement: 8.39 cm³
Horse power: 1.4 hp

Approvals:   

MECHANICAL DATA

Bore: 24.28 mm
Stroke: 18.12 mm
Oil Charge: 350ml +/-15ml
Free Internal Volume: 2.1 cm³
Maximum Recommended Refrigerant Charge: 350 g
Oil Type Configuration: Polyolester
Oil Type Viscosity: ISO22
Compressor pressurization: Dry air charge
Weight: 10.7 kg

ELECTRICAL DATA

Motor Type: RSIR
Starting Torque: LST
Voltage working range at 50 Hz: 198-254 V
Maximum Motor Temperature: 130 °C
Start Winding Resistance: 14.1 Ω (± 10%) at 25°C
Run Winding Resistance: 13 Ω (± 10%) at 25°C
Locked Rotor Amperage (LRA): 7 A

MOUNTING ACCESSORIES

	Description	Code
Terminal Board:	no	-
Overload Protector Bracket:	no	-
Capacitor Bracket:	no	-
Washer:	no	-
Pin:	no	-
Clip:	no	-
Rotolock valve:	no	-
Cover:	yes	2075282
Anchorage:	yes	1027058
Grommets:	yes	2221011
Sleeves:	yes	2222018

ELECTRICAL COMPONENTS

	Component type	Description	Code
Starting Device:	PTC	PTC 230V	1260011
Motor Protection:	External 3/4"	T0503/07 MRP357JZ-3166	2288072 2288306

EXTERNAL CHARACTERISTICS

Base Plate: European
Tray Holder: Yes
Height: 200 mm

	Internal Diameter (mm)	Material	Shape
Suction Connector	6.1	Copper	Slanted 42°
Discharge Connector	4.86	Copper	Straight
Process Connector	6.1	Copper	Slanted 42°

RATED POINT DATA

Cooling Capacity (W)	Power Consumption (W)	Current Consumption (A)	Gas Flow Rate (kg/h)	Efficiency (W/W)
±5%	±5%	±5%	±5%	±7%
228	160	0.96	4.41	1.42

Test condition: ASHRAE, Static, Return Gas 32.2°C, Evaporating: -23.3°C, Condensing: 54°C, Ambient: 32.2°C, Liquid: 32.2°C

PERFORMANCE CURVE DATA**220V 50Hz**

Condensing Temperature (°C)	Evaporating Temperature (°C)	Cooling Capacity (W)	Power Consumption (W)	Current Consumption (A)	Gas Flow Rate (kg/h)	Efficiency (W/W)
		±5%	±5%	±5%	±5%	±7%
35°C	-5	592	247	1.48	11.62	2.40
	-10	482	215	1.26	9.43	2.25
	-15	386	186	1.09	7.53	2.07
	-20	305	162	0.96	5.92	1.89
	-25	237	141	0.88	4.60	1.69
	-30	184	124	0.83	3.56	1.49

Condensing Temperature (°C)	Evaporating Temperature (°C)	Cooling Capacity (W)	Power Consumption (W)	Current Consumption (A)	Gas Flow Rate (kg/h)	Efficiency (W/W)
		±5%	±5%	±5%	±5%	±7%
45°C	-5	567	262	1.49	11.12	2.16
	-10	461	229	1.29	9.00	2.02
	-15	368	198	1.13	7.16	1.86
	-20	288	171	1.00	5.59	1.69
	-25	221	146	0.90	4.28	1.51
	-30	167	124	0.83	3.24	1.35

Condensing Temperature (°C)	Evaporating Temperature (°C)	Cooling Capacity (W)	Power Consumption (W)	Current Consumption (A)	Gas Flow Rate (kg/h)	Efficiency (W/W)
		±5%	±5%	±5%	±5%	±7%
55°C	-5	541	277	1.50	10.62	1.95
	-10	439	242	1.32	8.58	1.81
	-15	349	210	1.17	6.80	1.66
	-20	271	179	1.04	5.26	1.51
	-25	205	151	0.92	3.97	1.36

Test condition: ASHRAE, Static, Return Gas 32.2°C, Ambient: 32.2°C, Liquid: 32.2°C

ASSEMBLY INSTRUCTION

WIRING DIAGRAM

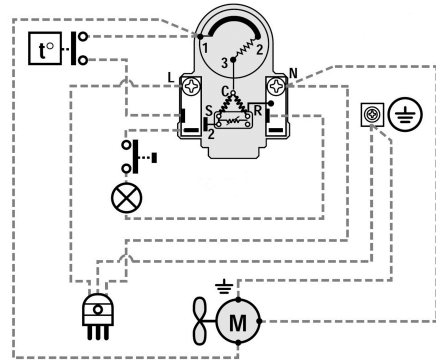
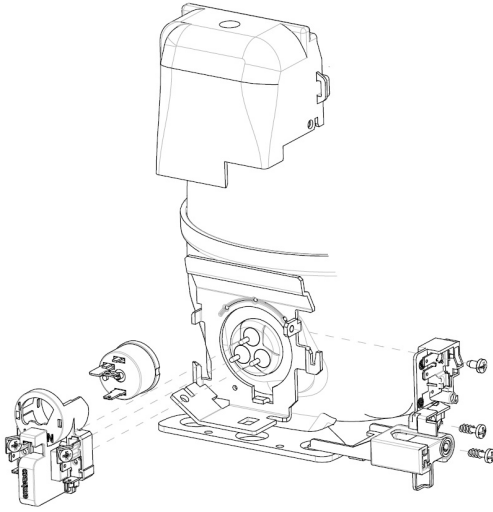

OPERATING ENVELOPE

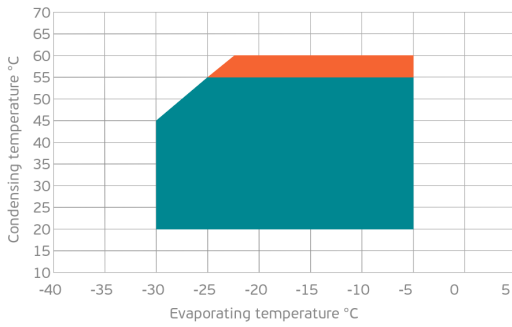

- Operating Condition
- Transient Condition
- Superheating

NOTE: usage of compressors outside of intended working range cannot make use of the warranty, or should be consulted with Technical support.

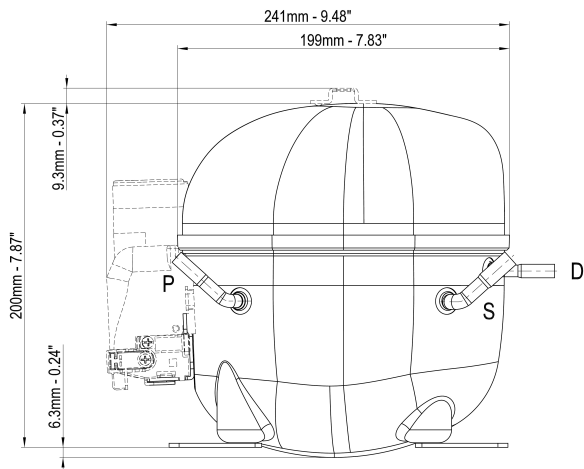

	∅ mm	∅ in	Material
S - Suction	6.10-6.20	0.24	Cu
P - Process	6.10-6.20	0.24	Cu
D - Discharge	4.86-5.03	0.19	Cu

