

*componenti per condizionamento e refrigerazione
refrigeration and A/C components*

NOVEMBER 2019

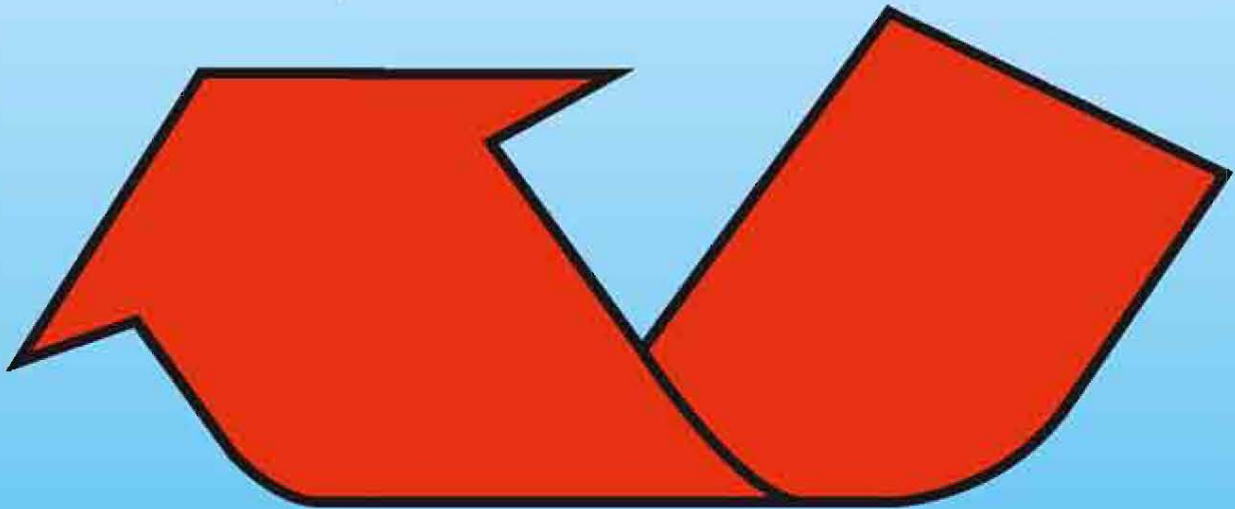
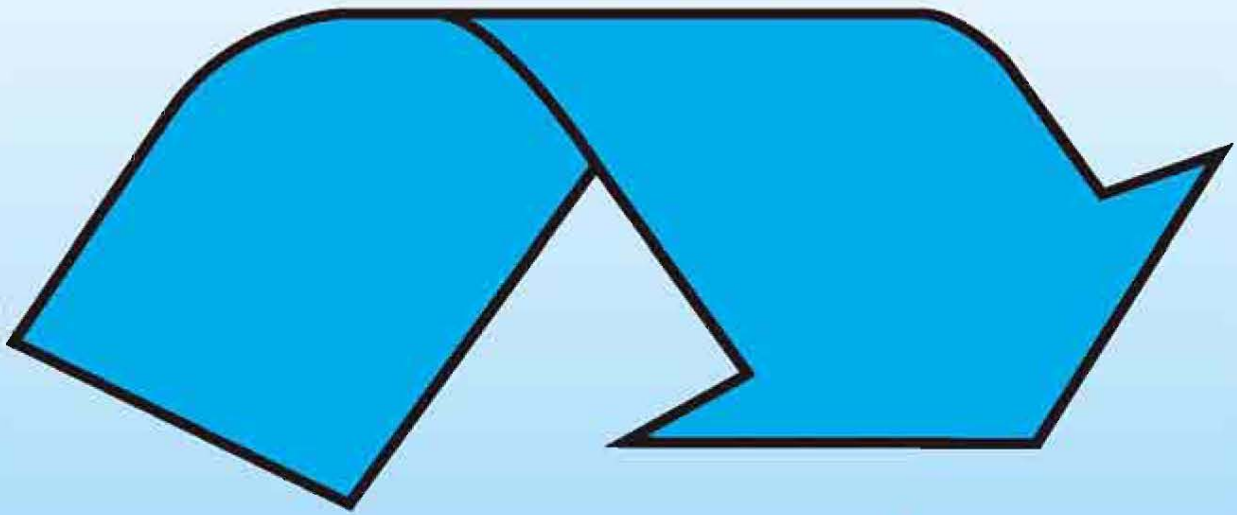

N A M A
G R O U P

DONPER

HERMETIC COMPRESSORS

R290 - R600 - R134a - R404a

www.namasrl.eu

sales@namasrl.eu

DONPER FACTORY



World-class Production Workshop

Nomenclature (NE, NCT series)

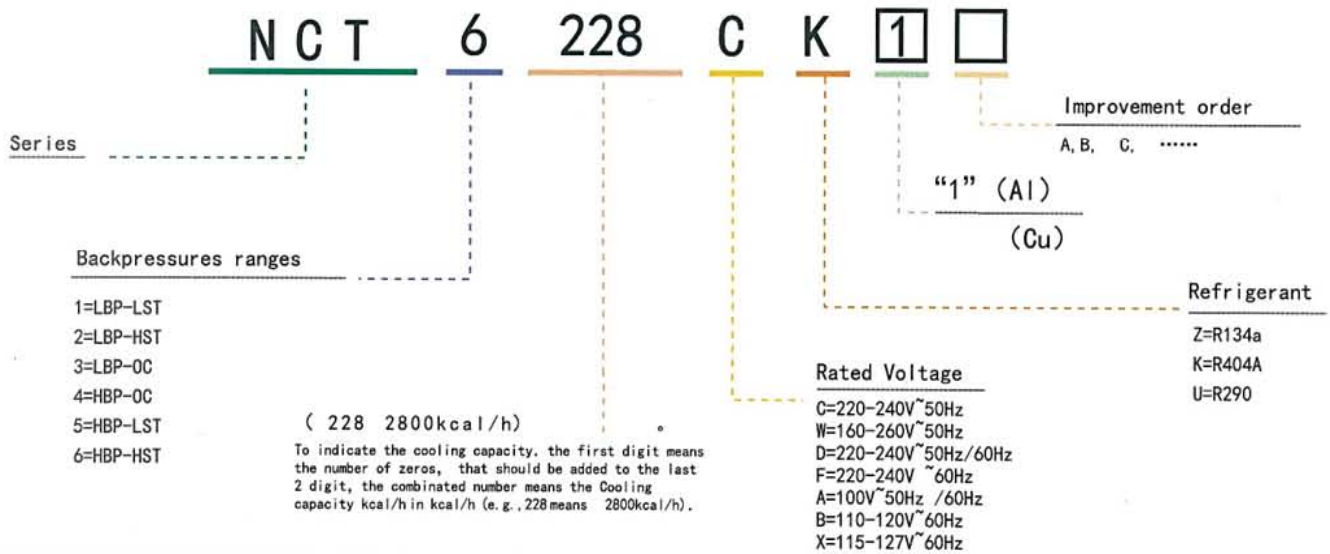

Capacity Range

Capacity at 50 Hz

W (LBP)	50	100	150	200	250	300	350	400	450	500	800	900	1100	
R600a	█													
R134a	█													
R290			█											

W (MHBP)	500	1000	1500	2000	2500	5000
R134a		█				
R404A		█				
R290		█				

Compressor nameplate identification

- Compressor model
- Donper's Logo
- Rated Voltage and frequency
- Donper Website
- Compressor bar code
- Number code
- Single phase
- Power supply connection mark
- Suction mark
- Flammable mark
- Refrigerant



Compressor Ranges

SERIES	COMPRESSOR	COMPRESSOR DESCRIPTION
VSC		<p>R600a, R290 30-260W, 120-320W VFL/VFX: 187×150×135mm (L×W×H) VFA: 177×142×120mm (L×W×H) VD: 165×142×114mm (L×W×H)</p> <p>CHEST FREEZER, REFRIGERATOR</p>
VC		<p>R134a 20-40W (L/MBP) 137×103×93mm (L×W×H)</p> <p>CAR REFRIGERATOR</p>
C		<p>R600a, R134a 50-100W (LBP) 137×117×145mm (L×W×H)</p> <p>WATER COOLER, SMALL CHEST FREEZER, ETC</p>
D		<p>R600a, R134a 50-100W (LBP) 146×127×158mm (L×W×H)</p> <p>SMALL FREEZER , WATER COOLER, ETC</p>
A		<p>R600a, R134a 48-140W (LBP) 157×142×163mm (L×W×H)</p> <p>SMALL FREEZER, WATER COOLER, REFRIGERATOR</p>

SERIES	COMPRESSOR	COMPRESSOR DESCRIPTION
S		<p>R600a, R134a, R290 100–200W (LBP) 400–700W (HBP) 177 × 148 × 169mm (L × W × H)</p> <p>CHEST FREEZER, REFRIGERATOR, DEHUMIDIFIER.</p>
L		<p>R600a, R134a, R290 200–450W (LBP) 600–1000W (HBP) 184 × 155 × 178mm (L × W × H)</p> <p>REFRIGERATOR, CHEST FREEZER, SHOW CASE, COMMERCIAL REFRIGERATOR, DEHUMIDIFIER, ETC.</p>
K		<p>R600a, R134a, R290 230–650W (LBP) 1000–1400W (HBP) 198 × 165 × 199mm (L × W × H)</p> <p>CHEST FREEZER, SHOW CASE, COMMERCIAL REFRIGERATOR, MEDICAL FREEZER, ICE MAKER, DEHUMIDIFIER, ETC.</p>
NE		<p>R134a, R290, R404A 450–900W (LBP) 800–2000W (HBP) 201 × 165 × 208mm (L × W × H)</p> <p>CHEST FREEZER, SHOW CASE, COMMERCIAL REFRIGERATOR, MEDICAL FREEZER, ICE MAKER, DRAFT BEER DISPENSER, ICE CREAM MACHINE, ETC.</p>
NCT		<p>R134a, R404A 950–1500W (LBP) 3320–4800W (HBP) 232 × 178 × 271mm (L × W × H)</p> <p>CHEST FREEZER, SHOW CASE, COMMERCIAL REFRIGERATOR, MEDICAL FREEZER, ICE MAKER, DRAFT BEER DISPENSER, ICE CREAM MACHINE, ETC.</p>

Model	Displacement	Cooling Type	Motor Type	Rotate Speed	ASHRAE (-23.3/54.4/32.2°C)					CECOMAF (-25/55/32°C)					Certification	motor	Height "A"
					Cooling Capacity			COP		Cooling Capacity			COP				
	cm ³			rpm	W	Kcal/h	Btu/h	W/W	EER	W	Kcal/h	Btu/h	W/W	EER			

VSC Series

R600a Variable Speed compressor (for 5 generation series Inverter) LBP

VFL070CY1H	7.0	ST	BLDC	1300	52	45	177	1.75	5.97	39	34	133	1.36	4.65	CCC	Al	135
				1600	65	56	222	1.83	6.24	49	42	167	1.42	4.86			
				2000	80	69	273	1.85	6.31	60	52	205	1.44	4.91			
				3000	125	107	427	1.75	5.97	94	81	321	1.36	4.65			
				4500	165	142	563	1.60	5.46	124	107	423	1.25	4.25			
VFL070CY1	7.0	ST	BLDC	1300	52	45	177	1.75	5.97	39	34	133	1.36	4.65	CCC/VDE	Al	135
				1600	65	56	222	1.83	6.24	49	42	167	1.42	4.86			
				2000	80	69	273	1.88	6.41	60	52	205	1.46	4.99			
				3000	125	107	427	1.80	6.14	94	81	321	1.40	4.78			
				4500	165	142	563	1.60	5.46	124	107	423	1.25	4.25			
VFL070CY	7.0	ST	BLDC	1300	52	45	177	1.83	6.24	39	34	133	1.42	4.86	CCC	Cu	135
				1600	65	56	222	1.91	6.52	49	42	167	1.49	5.07			
				2000	80	69	273	1.93	6.59	60	52	205	1.50	5.12			
				3000	125	107	427	1.83	6.24	94	81	321	1.42	4.86			
				4500	165	142	563	1.63	5.56	124	107	423	1.27	4.33			
VFL090CY1H	9.0	ST	BLDC	1300	72	62	246	1.75	5.97	55	47	188	1.36	4.64	CCC	Al	135
				1600	85	73	290	1.83	6.24	64	55	218	1.42	4.85			
				2000	108	93	368	1.85	6.31	81	70	276	1.44	4.91			
				3000	160	138	546	1.75	5.97	120	103	409	1.36	4.64			
				4500	215	185	734	1.60	5.46	162	139	553	1.25	4.27			
VFL090CY1	9.0	ST	BLDC	1300	72	62	246	1.80	6.14	54	47	185	1.40	4.78	CCC/VDE	Al	135
				1600	85	73	290	1.88	6.41	64	55	218	1.46	4.99			
				2000	108	93	368	1.90	6.48	81	70	277	1.48	5.04			
				3000	160	138	546	1.80	6.14	120	103	410	1.40	4.78			
				4500	215	185	734	1.60	5.46	162	139	552	1.25	4.25			
VFL090CY	9.0	ST	BLDC	1300	72	62	246	1.85	6.31	54	47	185	1.44	4.91	CCC	Cu	135
				1600	85	73	290	1.93	6.59	64	55	218	1.50	5.12			
				2000	108	93	368	1.95	6.65	81	70	277	1.52	5.18			
				3000	160	138	546	1.85	6.31	120	103	410	1.44	4.91			
				4500	215	185	734	1.65	5.63	162	139	552	1.28	4.38			
VFL110CY1H	11.0	ST	BLDC	1300	85	73	290	1.75	5.97	64	55	218	1.36	4.65	CCC	Al	135
				1600	108	93	368	1.83	6.24	81	70	277	1.42	4.86			
				2000	130	112	444	1.85	6.31	98	84	334	1.44	4.91			
				3000	200	172	682	1.75	5.97	150	129	513	1.36	4.65			
				4500	260	224	887	1.60	5.46	195	168	667	1.25	4.25			
VFL110CY1	11.0	ST	BLDC	1300	85	73	290	1.80	6.14	64	55	218	1.40	4.78	CCC/VDE	Al	135
				1600	108	93	368	1.88	6.41	81	70	277	1.46	4.99			
				2000	130	112	444	1.90	6.48	98	84	334	1.48	5.04			
				3000	200	172	682	1.80	6.14	150	129	513	1.40	4.78			
				4500	260	224	887	1.60	5.46	195	168	667	1.25	4.25			
VFL110CY	11.0	ST	BLDC	1300	85	73	290	1.85	6.31	64	55	218	1.44	4.91	CCC	Cu	135
				1600	108	93	368	1.93	6.59	81	70	277	1.50	5.12			
				2000	130	112	444	1.95	6.65	98	84	334	1.52	5.18			
				3000	200	172	682	1.85	6.31	150	129	513	1.44	4.91			
				4500	260	224	887	1.65	5.63	195	168	667	1.28	4.38			
VFL126CY1	12.6	ST	BLDC	1300	90	77	307	1.76	6.01	68	58	231	1.37	4.67	CCC	Al	135
				1600	120	103	409	1.85	6.31	90	78	308	1.44	4.91			
				2000	150	129	512	1.88	6.41	113	97	385	1.46	4.99			
				3000	225	193	768	1.76	6.01	169	145	577	1.37	4.67			
				4500	280	241	955	1.58	5.39	211	181	718	1.23	4.20			
VFL126CY	12.6	ST	BLDC	1300	90	77	307	1.81	6.18	68	58	231	1.41	4.81	CCC	Cu	135
				1600	120	103	409	1.90	6.48	90	78	308	1.48	5.04			
				2000	150	129	512	1.93	6.59	113	97	385	1.50	5.12			
				3000	225	193	768	1.81	6.18	169	145	577	1.41	4.81			
				4500	280	241	955	1.63	5.56	211	181	718	1.27	4.33			

Series	Model	Displacement cm ³	Cooling Type	Motor Type	ASHRAE (-23.3/54.4/32.2°C)					CECOMAF (-25/55/32°C)					Run Capacitor μF	StartCapacitor μF	Certification	Starter	motor	Height "A"
					Cooling Capacity			COP		Cooling Capacity			COP							
		W			Kcal/h	Btu/h	W/W	EER	W	Kcal/h	Btu/h	W/W	EER							

Household Series

220-240V~50Hz R600a LBP

A	AK50CY1	3.6	ST	RSCR	48	41	164	1.42	4.85	36	31	123	1.11	3.77	3		CCC/VDE	PTC	AI	155
C	C50CY1	4.0	ST	RSIR	50	43	171	0.95	3.24	38	32	128	0.74	2.52			CCC	PTC	AI	136
D	D40CY1	4.0	ST	RSIR	50	43	171	1.10	3.75	38	32	128	0.86	2.92			CCC/VDE	PTC	AI	140
D	DG40CY1	4.0	ST	RSIR	50	43	171	1.28	4.37	38	32	128	1.00	3.40			CCC/VDE	PTC	AI	147
D	D43CY1	4.3	ST	RSIR	65	56	222	1.20	4.09	49	42	167	0.93	3.19			CCC/VDE	PTC	AI	144
A	AU70CY1	4.5	ST	RSCR	68	58	232	1.60	5.46	51	44	174	1.25	4.25	2		CCC/VDE	PTC	AI	155
A	AZ70CY1	4.5	ST	ESCR	68	58	232	1.70	5.80	51	44	174	1.32	4.51	2.5		CCC/VDE	EPTC	AI	157
C	C75CY1	5.3	ST	RSIR	75	64	256	0.95	3.24	56	48	192	0.74	2.52			CCC/VDE	PTC	AI	143
D	D53CY1	5.3	ST	RSIR	80	69	273	1.20	4.09	60	52	205	0.93	3.19			CCC/VDE	PTC	AI	152
D	DG53CY1	5.3	ST	RSIR	80	69	273	1.35	4.61	60	52	205	1.05	3.58			CCC	PTC	AI	157
A	A80CY1	5.3	ST	RSIR	80	69	273	1.30	4.44	60	52	205	1.01	3.45			CCC/VDE	PTC	AI	155
A	AK80CY1	5.3	ST	RSCR	80	69	273	1.50	5.12	60	52	205	1.17	3.98	3		CCC	PTC	AI	157
A	AZ80CY1A*	5.5	ST	ESCR	80	47	273	1.70	5.80	60	52	205	1.32	4.51	3			EPTC	AI	163
A	AJ90CYA	6.0	ST	ESCR	90	77	307	1.80	6.14	68	58	231	1.40	4.78	2.5			EPTC	Cu	165
D	D65CY1	6.0	ST	RSIR	95	82	324	1.20	4.09	71	61	244	0.93	3.19			CCC/VDE	PTC	AI	152
S	SM60CY1*	6.0	ST	ESCR	95	82	324	1.78	6.07	71	61	244	1.39	4.73	3			EPTC	AI	168
S	SJ60CY1*	6.0	ST	ESCR	95	82	324	1.83	6.24	71	61	244	1.42	4.86	2.5			EPTC	AI	171
S	SR60CY1	6.0	ST	ESCR	95	82	324	1.86	6.35	71	61	244	1.45	4.94	2.5		/	EPTC	AI	168
L	LC58CY1	5.8	ST	ESCR	95	82	324	1.92	6.55	71	61	244	1.49	5.10	2.5		CCC	EPTC	AI	177
L	LD58CY1	5.8	ST	ESCR	95	82	324	1.96	6.69	71	61	244	1.53	5.20	2.5		CCC/VDE	EPTC	AI	177
A	A100CY1	6.2	ST	RSIR	98	84	334	1.30	4.44	74	63	251	1.01	3.45				PTC	AI	157
A	AG100CY1	6.2	ST	RSIR	98	84	334	1.42	4.85	74	63	251	1.11	3.77	3		CCC/VDE	PTC	AI	157
A	AK100CY1A	6.2	ST	RSIR	98	84	334	1.55	5.29	74	63	251	1.21	4.12			TUV	PTC	AI	163
A	AU100CY1A	6.2	ST	RSCR	98	84	334	1.58	5.39	74	63	251	1.23	4.20	2.5			PTC	AI	163
A	AZ100CY1A	6.2	ST	RSCR	98	84	334	1.70	5.80	74	63	251	1.32	4.51	2.5		CCC	EPTC	AI	163
A	AM100CY1A	6.2	ST	ESCR	98	84	334	1.75	5.97	74	63	251	1.36	4.65	2.5			EPTC	AI	163
L	LC66CY	6.6	ST	ESCR	108	93	368	1.92	6.55	81	70	277	1.49	5.10	3		CCC	EPTC	Cu	177
L	LD66CY	6.6	ST	ESCR	108	93	368	1.96	6.69	81	70	277	1.53	5.20	3		CCC	EPTC	Cu	177
A	A120CY1	7.2	ST	RSIR	118	101	403	1.25	4.27	89	76	303	0.97	3.32			CCC/VDE	PTC	AI	153
A	AG120CY1	7.2	ST	RSIR	118	101	403	1.40	4.78	89	76	303	1.09	3.72			CCC/VDE	PTC	AI	157
A	AK120CY1	7.2	ST	RSCR	118	101	403	1.45	4.95	89	76	303	1.13	3.85	3		CCC/VDE	PTC	AI	157
A	AU120CY1A	7.2	ST	RSIR	118	101	403	1.58	5.39	89	76	303	1.23	4.20			CCC/VDE	PTC	AI	163
A	AU120CY1B	7.2	ST	RSCR	118	101	403	1.60	5.46	89	76	303	1.25	4.25	2.5		CCC	PTC	AI	163
A	AZ120CY1A	7.2	ST	ESCR	118	101	403	1.70	5.80	89	76	303	1.32	4.51	2.5		CCC/TUV	EPTC	AI	163
L	LC70CY1	7.0	ST	ESCR	118	101	403	1.92	6.55	89	76	303	1.49	5.10	3		CCC/VDE	EPTC	AI	177
L	LD70CY1	7.0	ST	ESCR	118	101	403	1.96	6.69	89	76	303	1.53	5.20	3		CCC	EPTC	AI	177
S	SM75CY1	7.5	ST	ESCR	120	103	409	1.78	6.07	90	78	308	1.39	4.73	3		CCC/VDE	EPTC	AI	171
S	SJ75CY1*	7.5	ST	ESCR	120	103	409	1.83	6.24	90	78	308	1.42	4.86	3			EPTC	AI	171
S	SR75CY1*	7.5	ST	ESCR	120	103	409	1.86	6.35	90	78	308	1.45	4.94	3			EPTC	AI	168
A	AU130CY1A	8.0	ST	RSCR	128	110	437	1.58	5.39	96	83	328	1.23	4.20	4		CCC	PTC	AI	163
A	A140CY1	8.8	ST	RSIR	138	120	471	1.25	4.27	104	89	354	0.97	3.32			CCC/VDE	PTC	AI	157
A	AK140CY1A	8.8	ST	RSCR	138	120	471	1.50	5.12	104	89	354	1.17	3.98	4		CCC	PTC	AI	157
A	AU140CY1A	8.8	ST	RSCR	138	120	471	1.60	5.46	104	89	354	1.25	4.25	4		CCC	PTC	AI	163
A	AZ140CY1A	8.8	ST	ESCR	138	120	471	1.70	5.80	104	89	354	1.32	4.51	4		CCC	EPTC	AI	163
S	SM80CY1	8.0	ST	ESCR	138	119	471	1.75	5.97	104	89	354	1.36	4.65	4		CCC	EPTC	AI	168
S	SJ80CY1	8.0	ST	ESCR	138	119	471	1.83	6.24	104	89	354	1.42	4.86	4		CCC	EPTC	AI	169
S	SR80CY1	8.0	ST	ESCR	138	119	471	1.86	6.35	104	89	354	1.45	4.94	4			EPTC	AI	168
L	LC82CY1	8.2	ST	ESCR	138	119	471	1.92	6.55	104	89	354	1.49	5.10	3		CCC/VDE	EPTC	AI	177
S	SZ96CY1	9.6	ST	RSCR	155	133	529	1.70	5.80	117	100	398	1.32	4.51	4			PTC	AI	168
S	SJ96CY1	9.6	ST	ESCR	155	133	529	1.83	6.24	117	100	398	1.42	4.86	4			EPTC	AI	168
L	LR88CY1	8.8	ST	ESCR	158	136	539	1.88	6.41	119	102	405	1.46	4.99	4		CCC	EPTC	AI	177
S	S100CY1	10.0	ST	RSIR	168	144	573	1.35	4.61	126	109	431	1.05	3.58				PTC	AI	164
S	SK100CY1	10.0	ST	RSIR	168	144	573	1.52	5.19	126	109	431	1.18	4.04				PTC	AI	164
S	SU100CY1	10.0	ST	RSCR	168	144	573	1.60	5.46	126	109	431	1.25	4.25	4			PTC	AI	168

Series	Model	Displacement	Cooling Type	Motor Type	ASHRAE (-23.3/54.4/32.2°C)					CECOMAF (-25/55/32°C)					Run Capacitor	StartCapacitor	Certification	Starter	motor	Height "A"
					Cooling Capacity			COP		Cooling Capacity			COP							
		cm ³	W	Kcal/h	Btu/h	W/W	EER	W	Kcal/h	Btu/h	W/W	EER	μF	μF						

Household Series

220-240V~50Hz R600a LBP

S	SZ100CY1	10.0	ST	RSCR	168	144	573	1.75	5.97	126	109	431	1.36	4.65	4			PTC	AI	168
S	SJ100CY1	10.0	ST	ESCR	168	144	573	1.83	6.24	126	109	431	1.42	4.86	4			EPTC	AI	168
L	LR100CY1	10.0	S	ESCR	168	144	573	1.88	6.41	126	109	431	1.46	4.99	4		CCC	EPTC	AI	177
L	LC100CY1	10.0	S	ESCR	168	144	573	1.92	6.55	126	109	431	1.49	5.10	4		CCC/VDE	EPTC	AI	177
L	LD100CY1	10.0	S	ESCR	168	144	573	1.96	6.69	126	109	431	1.53	5.20	4		CCC	EPTC	AI	177
S	SU111CY1	11.1	ST	RSCR	185	159	631	1.65	5.63	139	120	475	1.28	4.38	4			PTC	AI	168
S	SZ111CY1	11.1	ST	RSCR	185	159	631	1.73	5.90	139	120	475	1.35	4.59	4			PTC	AI	168
S	SJ111CY1	11.1	ST	ESCR	185	159	631	1.83	6.24	139	120	475	1.42	4.86	4			EPTC	AI	169
L	LR111CY1	11.1	ST	ESCR	185	159	631	1.88	6.41	139	120	475	1.46	4.99	4		CCC	EPTC	AI	177
L	LC111CY	11.1	ST	ESCR	185	159	631	1.92	6.55	139	120	475	1.49	5.10	4		CCC	EPTC	Cu	177
S	S118CY1	11.8	ST	RSIR	193	166	659	1.38	4.71	145	125	495	1.07	3.66			CCC	PTC	AI	168
L	LK118CY1	11.8	ST	RSCR	193	166	659	1.50	5.12	145	125	495	1.17	3.98	5		CCC/VDE	PTC	AL	174
L	LU118CY1	11.8	ST	RSCR	193	166	659	1.60	5.46	145	125	495	1.25	4.27	5		CCC/VDE	PTC	AL	174
L	LJ118CY1	11.8	ST	ESCR	193	166	659	1.82	6.21	145	125	495	1.42	4.83	5		CCC/VDE	EPTC	AI	177
L	LR118CY1	11.8	ST	ESCR	193	166	659	1.86	6.35	145	125	495	1.45	4.94	5		CCC	EPTC	AI	177
L	LC118CY1*	11.8	ST	ESCR	193	166	659	1.91	6.52	145	125	495	1.49	5.07	4			EPTC	AI	177
L	L126CY1	12.6	ST	RSIR	212	182	723	1.36	4.64	159	137	544	1.06	3.61			CCC/VDE	PTC	AI	174
L	LU126CY1	12.6	ST	RSCR	212	182	723	1.60	5.46	159	137	544	1.25	4.25	5		CCC/VDE	PTC	AI	177
L	LJ126CY1	12.6	ST	ESCR	212	182	723	1.82	6.21	159	137	544	1.42	4.83	4		CCC	EPTC	AI	177
L	LR126CY1*	12.6	ST	ESCR	212	182	723	1.86	6.35	159	137	543	1.45	4.95	4			EPTC	AI	177
L	LC126CY	12.6	ST	ESCR	212	182	723	1.92	6.55	159	137	544	1.49	5.10	4		CCC	EPTC	Cu	177
L	L140CY1	14.0	F	RSIR	235	202	802	1.36	4.64	177	152	603	1.06	3.61			CCC	PTC	AI	174
L	LU140CY1	14.0	F	RSCR	235	202	802	1.60	5.46	177	152	603	1.25	4.25	5		CCC	PTC	AI	177
L	LZ140CY1	14.0	F	RSCR	235	202	802	1.70	5.80	177	152	603	1.32	4.51	5		CCC	PTC	AI	177
L	LM140CY1	14.0	F	ESCR	235	202	802	1.75	5.97	177	152	604	1.36	4.65	5		CCC	EPTC	AL	177
L	LJ140CY1	14.0	F	ESCR	235	202	802	1.82	6.21	177	152	603	1.42	4.83	5		CCC	EPTC	AI	177
L	LU150CY1*	15.0	F	RSCR	260	224	887	1.60	5.46	195	168	667	1.25	4.25	6			PTC	AI	174
K	K270CY1	16.2	F	RSIR	265	228	904	1.30	4.44	199	171	680	1.01	3.45			CCC/VDE	PTC	AI	189
K	KK270CY1	16.2	F	RSCR	265	228	904	1.50	5.12	199	171	680	1.17	3.98	5		CCC	PTC	AI	189
K	KU270CY1	16.2	F	RSCR	265	228	904	1.60	5.46	199	171	680	1.25	4.25	5		CCC VDE	PTC	AI	189
K	KJ270CY	16.2	F	ESCR	265	228	904	1.82	6.21	199	171	680	1.42	4.83	5		CCC	EPTC	AI	189
K	KR270CY	16.2	F	ESCR	265	228	904	1.88	6.41	199	171	680	1.46	4.99	5		CCC	EPTC	AI	189
L	LU170CY1*	17.0	F	RSCR	280	241	955	1.60	5.46	211	181	718	1.25	4.25	6			PTC	AI	174
K	K290CY1	18.3	F	RSIR	290	249	989	1.30	4.44	218	187	744	1.01	3.45			CCC	PTC	AI	189

Series	Model	Horse Power	Displacement	Cooling Type	Motor Type	ASHRAE (-23. 3/54. 4/32. 2°C)					CECOMAF (-25/55/32°C)					Run Capacitor	StartCapacitor	Certification	Starter	motor	Height "A"
		HP	cm ³			Cooling Capacity			COP		Cooling Capacity			COP							
						W	Kcal/h	Btu/h	W/W	EER	W	Kcal/h	Btu/h	W/W	EER						

220-240V~50Hz R290 L/MBP

S	S43CU1	1/4-	4.3	ST	RSIR	200	172	682	1.30	4.44	150	129	513	1.01	3.45			CCC VDE	PTC	AI	168
S	SK43CU	1/4-	4.3	ST	RSCR	200	172	682	1.50	5.12	150	129	513	1.17	3.98	5		CCC VDE	PTC	Cu	168
S	S50CU1	1/4+	5	ST	RSIR	220	189	751	1.30	4.44	165	142	564	1.01	3.45			CCC	PTC	AI	168
S	SU50CU1	1/4+	5.0	F	RSCR	220	189	751	1.55	5.29	165	142	564	1.21	4.12	5		CCC VDE	PTC	AI	171
S	SZ50CU1	1/4+	5.0	F	RSCR	220	189	751	1.70	5.80	165	142	564	1.32	4.51	5		VDE	PTC	AI	171
L	L45CU1	1/3-	4.5	F	RSIR	255	219	870	1.30	4.44	192	165	654	1.01	3.45			CCC VDE	PTC	AI	175
L	LK45CU1	1/3-	4.5	F	RSCR	255	219	870	1.50	5.12	192	165	654	1.17	3.98	5		CCC VDE	PTC	AI	175
L	L58CU1	1/3+	5.8	F	RSIR	275	236	938	1.30	4.44	207	178	705	1.01	3.45			CCC VDE	PTC	AI	168
L	LZ58CU	1/3+	5.8	F	RSCR	275	236	938	1.65	5.63	207	178	705	1.28	4.38	5		CCC VDE	PTC	Cu	175
L	LJ58CU	1/3+	5.8	F	ESCR	275	236	938	1.83	6.24	207	178	705	1.42	4.86	5			EPTC	Cu	175
L	L68CU1	3/8+	6.8	F	RSIR	325	279	1109	1.30	4.44	244	210	834	1.01	3.45			CCC	PTC	AI	168
L	L68CU	3/8+	6.8	F	RSIR	325	279	1109	1.30	4.44	244	210	834	1.01	3.45			CCC VDE	PTC	Cu	168
L	LK68CU1	3/8+	6.8	F	RSCR	325	279	1109	1.50	5.12	244	210	834	1.17	3.98	5		CCC VDE	PTC	AI	171
L	LK68CU	3/8+	6.8	F	CSIR	325	279	1109	1.50	5.12	244	210	834	1.17	3.98		50	CCC VDE	CURRENT	Cu	171
L	LU68CU1	3/8+	6.8	F	RSCR	325	279	1109	1.60	5.46	244	210	834	1.25	4.25	5		CCC	PTC	AI	171
L	LZ68CU	3/8+	6.8	F	RSCR	325	279	1109	1.70	5.80	244	210	834	1.32	4.51	5		CCC VDE	PTC	Cu	175
L	LJ68CU	3/8+	6.8	F	ESCR	325	279	1109	1.82	6.21	244	210	834	1.42	4.83	5		CCC	EPTC	Cu	177
L	L76CU1	1/2	7.6	F	RSIR	380	327	1297	1.30	4.44	286	246	975	1.01	3.45			CCC VDE	PTC	AI	175
L	LK76CU1	1/2	7.6	F	RSCR	380	327	1297	1.50	5.12	286	246	975	1.17	3.98	5		CCC VDE	PTC	AI	175
L	LU76CU1	1/2	7.6	F	RSCR	380	327	1297	1.60	5.46	286	246	975	1.25	4.25	5		CCC	PTC	AI	177
L	LZ76CU	1/2	7.6	F	RSCR	380	327	1297	1.70	5.80	286	246	975	1.32	4.51	5		CCC VDE	PTC	Cu	175
K	K400CU	1/2+	9.6	F	CSIR	400	344	1365	1.30	4.44	301	259	1026	1.01	3.45		50	CCC	CURRENT	Cu	189
L	L83CU1	1/2+	8.3	F	CSIR	400	344	1365	1.40	4.78	301	259	1026	1.09	3.72		50	CCC/TUV	CURRENT	AI	175
L	LK83CU	1/2+	8.3	F	RSCR	400	344	1365	1.50	5.12	301	259	1026	1.17	3.98	5		CCC VDE	PTC	Cu	175
L	LK83CU1	1/2+	8.3	F	RSCR	400	344	1365	1.50	5.12	301	259	1026	1.17	3.98	6	50	CCC/TUV	CURRENT	AI	175
L	L90CU1	3/4-	9.0	F	CSIR	450	387	1535	1.40	4.78	338	291	1153	1.09	3.72		50		CURRENT	AI	179
L	LK90CU	3/4-	9.0	F	CSIR	450	387	1535	1.50	5.12	338	291	1154	1.17	3.98		50		CURRENT	Cu	177
L	LU100CU	3/4	10.0	F	CSR	480	413	1638	1.60	5.46	361	310	1231	1.25	4.25	6	50		CURRENT	Cu	179
K	K480CU1	3/4-	10.9	F	CSIR	480	413	1638	1.30	4.44	361	310	1232	1.01	3.45		50	CCC	CURRENT	AI	189
K	K480CU	3/4-	10.9	F	CSIR	480	413	1638	1.30	4.44	361	310	1231	1.01	3.45		50	CCC VDE	CURRENT	Cu	189

Series	Model	Horse Power		Displacement	Cooling Type	Motor Type	ASHRAE (-23.3/54.4/32.2°C)					CECOMAF (-25/55/32°C)					Run Capacitor	StartCapacitor	Certification	Starter	motor	Height "A"
		HP	cm ³				Cooling Capacity			COP		Cooling Capacity			COP							
				W	Kcal/h	Btu/h	W/W	EER	W	Kcal/h	Btu/h	W/W	EER	μF	μF							

220-240V~50Hz R290 L/MBP

K	KK480CU	3/4-	10.9	F	CSR	480	413	1638	1.50	5.12	361	310	1232	1.17	3.98	6	50	CCC	CURRENT	Cu	198
K	KK480CU1	3/4-	10.9	F	CSR	480	413	1638	1.50	5.12	361	310	1232	1.17	3.98	6	50		CURRENT	Al	198
K	KK550CU	3/4	11.4	F	CSR	550	473	1877	1.50	5.12	414	356	1411	1.17	3.98	6	50	CCC	CURRENT	Cu	198
K	KU550CU	3/4	11.4	F	CSR	550	473	1877	1.60	5.46	414	356	1411	1.25	4.25	6	50	CCC	CURRENT	Cu	198
NE	NE2150CU	3/5	13.5	F	CSIR	580	499	1979	1.30	4.44	436	375	1488	1.01	3.45		75	CCC	CURRENT	Cu	196
K	KK650CU	1/2	14.3	F	CSR	650	559	2218	1.50	5.12	489	420	1668	1.17	3.98	6	50	CCC	CURRENT	Cu	198
NE	NE2168CU	3/4	16.7	F	CSR	780	671	2661	1.45	4.95	586	504	2001	1.13	3.85	15	100	CCC	CURRENT	Cu	200

Series	Model	Horse Power		Displacement	Cooling Type	Motor Type	ASHRAE (7.2/35/54.4°C)					CECOMAF (5/55/32°C)					Run Capacitor	StartCapacitor	Certification	Starter	motor	Height "A"
		HP	cm ³				Cooling Capacity			COP		Cooling Capacity			COP							
				W	Kcal/h	Btu/h	W/W	EER	W	Kcal/h	Btu/h	W/W	EER	μF	μF							

220-240V~50Hz R290 M/HBP

L	L6155CU1*	1/5	4.5	F	CSIR	620	533	2115	2.50	8.53	466	401	1590	1.95	6.65		50		CURRENT	Al	179
L	L6170CU	1/4+	5.8	F	CSIR	790	679	2695	2.50	8.53	594	511	2027	1.95	6.65		50	CCC	CURRENT	Cu	177
L	L6180CU	3/4-	6.8	F	CSIR	920	791	3139	2.50	8.53	692	595	2360	1.95	6.65		50	CCC CE	CURRENT	Cu	179
L	L6186CU	3/4	7.6	F	CSIR	1000	860	3412	2.50	8.53	752	647	2565	1.95	6.65		50	CCC	CURRENT	Cu	179
K	K6196CU	1/3+	8.3	F	CSIR	1100	945	3753	2.50	8.53	825	710	2815	1.95	6.65		50	CCC	CURRENT	Cu	198
K	K6212CU	2/5+	9.5	F	CSR	1300	1117	4436	2.50	8.53	975	838	3327	1.95	6.65	6	75	CCC	CURRENT	Cu	198
NE	NE6214CU	1/2+	12	F	CSR	1600	1419	5459	2.50	8.53	1238	1067	4224	1.95	6.65	15	75		CURRENT	Cu	200
NE	NE6217CU	3/5+	14.2	F	CSR	1900	1634	6483	2.30	7.85	1425	1228	4862	1.95	6.65	15	75		CURRENT	Cu	200

Model	Displacement	Cooling Type	Motor Type	Rotate Speed	ASHRAE (-23.3/54.4/32.2°C)					CECOMAF (-25/55/32°C)					Certification	motor	Height "A"
					Cooling Capacity			COP		Cooling Capacity			COP				
	cm ³			rpm	W	Kcal/h	Btu/h	W/W	EER	W	Kcal/h	Btu/h	W/W	EER			

R134a Direct Current Variable Speed Compressor L/MBP

VC25EZ	1.5	ST	BLDC	2000	17	15	58	1.00	3.41	13	11	44	0.78	2.66	CCC	Cu	93
				2500	21	18	72	0.96	3.28	16	14	54	0.75	2.55			
				3000	25	21	85	0.93	3.17	19	16	64	0.72	2.47			
				3500	29	25	99	0.90	3.07	22	19	74	0.70	2.39			
C50EZ	2.5	ST	BLDC	2000	35	30	119	1.20	4.09	26	23	90	0.93	3.19	CCC	Cu	137
				2500	42	36	143	1.18	4.03	32	27	108	0.92	3.13			
				3000	50	43	171	1.15	3.92	38	32	128	0.89	3.05			
				3500	58	50	198	1.10	3.75	44	37	149	0.86	2.92			
C70EZ	3.0	ST	BLDC	2000	48	41	164	1.20	4.09	36	31	123	0.93	3.19	CCC	Cu	137
				2500	59	51	201	1.18	4.03	44	38	151	0.92	3.13			
				3000	70	60	239	1.15	3.92	53	45	180	0.89	3.05			
				3500	80	69	273	1.10	3.75	60	52	205	0.86	2.92			
C100EZ	4.2	ST	BLDC	2000	70	60	239	1.13	3.86	53	45	180	0.88	3.00	CCC	Cu	137
				2500	85	73	290	1.10	3.75	64	55	218	0.86	2.92			
				3000	100	86	341	1.08	3.68	75	65	257	0.84	2.87			
				3500	113	97	386	1.05	3.58	85	73	290	0.82	2.79			

Frequency Inverter compressor wiring diagrams

DC

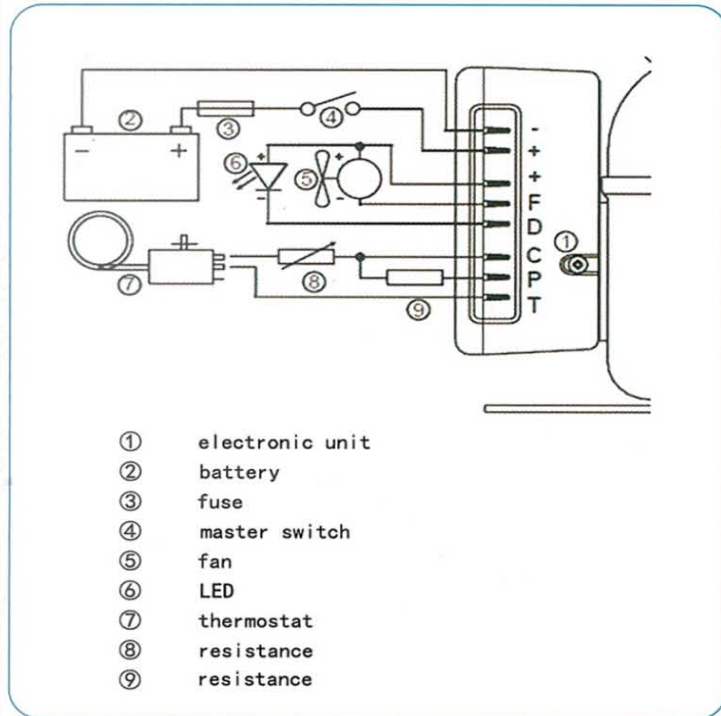

AC

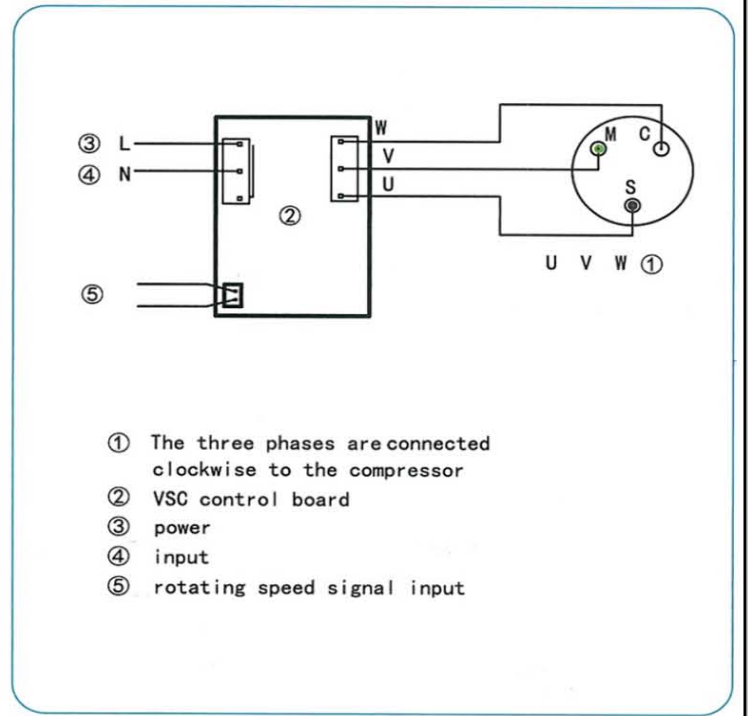

Series	Model	Displacement		Cooling Type	Motor Type	ASHRAE (-23.3/54.4/32.2°C)					CECOMAF (-25/55/32°C)					Run Capacitor	StartCapacitor	Certification	Starter	motor	Height "A"	
		cm ³	Cooling Capacity			COP		Cooling Capacity			COP		μF	μF								
			W			Kcal/h	Btu/h	W/W	EER	W	Kcal/h	Btu/h			W/W							EER

Household Series

220-240V~50Hz R134a LBP

D	D30CZC	3.0	ST	RSIR	75	64	256	1.10	3.75	56	48	192	0.86	2.92				PTC	Cu	157
D	DK30CZ1	3.0	ST	RSIR	70	60	239	1.28	4.37	53	45	180	1.00	3.40			CCC/VDE	PTC	AI	152
S	S65CZ1	6.5	ST	RSIR	170	146	580	1.30	4.44	128	110	436	1.01	3.45				PTC	AI	168
L	LK65CZ1	6.5	ST	RSCR	175	150	597	1.50	5.12	132	113	449	1.17	3.98	4		CCC	PTC	AI	174
L	LM65CZ	6.5	ST	ESCR	175	150	597	1.70	5.80	132	113	449	1.32	4.51	4		CCC	EPTC	Cu	177
L	LJ65CZ	6.5	ST	ESCR	175	150	597	1.78	6.07	132	113	449	1.39	4.73	4		CCC/VDE	EPTC	Cu	179
L	LU70CZ	7.0	ST	RSCR	190	163	648	1.55	5.29	143	123	487	1.21	4.12	5		CCC/VDE	PTC	Cu	174
S	S72CZ1	7.2	ST	RSIR	195	168	665	1.35	4.61	147	126	500	1.05	3.58				PTC	AI	168
L	LK72CZ	7.2	ST	RSCR	195	168	665	1.50	5.12	147	126	500	1.17	3.98	4		CCC	PTC	Cu	170
L	LM72CZ	7.2	ST	ESCR	195	168	665	1.70	5.80	147	126	500	1.32	4.51	4		CCC	EPTC	Cu	177
L	L76CZ1	7.6	ST	RSIR	215	185	734	1.30	4.44	162	139	552	1.01	3.45			CCC/VDE	PTC	AI	179
L	L83CZ1	8.3	F	RSIR	230	198	785	1.30	4.44	173	149	590	1.01	3.45			CCC/CB	PTC	AI	179
K	KK230CZ1	8.3	F	RSCR	230	198	785	1.50	5.12	173	149	590	1.17	3.98	5		CCC/VDE	PTC	AI	189
K	KM230CZ	8.3	F	ESCR	230	198	785	1.70	5.80	173	149	590	1.32	4.51	5		CCC/VDE	EPTC	Cu	189
K	K270CZ1	9.5	F	CSIR	270	232	921	1.30	4.44	203	175	693	1.01	3.45			CCC/VDE	CURRENT	AI	189
K	KK270CZ1	9.5	F	RSCR	270	232	921	1.50	5.12	203	175	693	1.17	3.98	5		CCC/VDE	PTC	AI	189
K	K325CZ1	11.4	F	CSIR	325	279	1109	1.30	4.44	244	210	834	1.01	3.45		50	CCC/VDE	CURRENT	AI	198
K	K375CZ1	12.7	F	CSIR	375	322	1280	1.30	4.44	282	242	962	1.01	3.45		50	CCC/VDE	CURRENT	AI	198
K	K400CZ1	14.3	F	CSR	400	344	1365	1.30	4.44	301	259	1026	1.01	3.45	6	50	CCC	CURRENT	AI	198

Series	Model	Horse Power		Displacement	Cooling Type	Motor Type	ASHRAE (7.2/35/54.4°C)					CECOMAF (5/55/32°C)					Run Capacitor	StartCapacitor	Certification	Starter	motor	Height "A"		
		HP	cm ³				Cooling Capacity			COP		Cooling Capacity			COP								μF	μF
							W	Kcal/h	Btu/h	W/W	EER	W	Kcal/h	Btu/h	W/W	EER								

Commercial Series

220-240V~50Hz R134a M/HBP

D	D5136CZ1	1/7	4.1	F	RSIR	420	361	1433	2.30	7.85	344	296	1174	2.05	6.99				PTC	AI	152
S	S5150CZ1*	1/5	6	F	RSIR	650	559	2218	2.30	7.85	533	458	1819	2.05	6.99				PTC	AI	167
S	S6160CZ1	1/4	7.2	F	RSIR	750	645	2559	2.30	7.85	615	529	2098	2.05	6.98			CCC/CE	PTC	AI	167
L	L6170CZ	1/4+	7.9	F	CSIR	850	731	2900	2.30	7.85	697	599	2378	2.05	6.98		50	CCC/CE	CURRENT	Cu	175
NE	NE5170CZ	1/3	9.8	F	RSIR	930	800	3173	2.20	7.51	763	656	2602	1.96	6.68			CE	CURRENT	Cu	196
	NE6188CZ	3/8	12.0	F	CSIR	1100	946	3753	2.30	7.85	902	776	3078	2.05	6.98		75	CCC/CE	CURRENT	Cu	196
K	K6210CZ	3/8	11.4	F	CSIR	1200	1032	4094	2.40	8.19	984	846	3357	2.14	7.29		75	CCC/CE	CURRENT	Cu	198

Series	Model	Horse Power	Displacement	Cooling Type	Motor Type	ASHRAE (7.2/35/54.4°C)					CECOMAF (5/55/32°C)					Run Capacitor	StartCapacitor	Certification	Starter	motor	Height "A"
		HP	cm ³			Cooling Capacity			COP		Cooling Capacity			COP							
						W	Kcal/h	Btu/h	W/W	EER	W	Kcal/h	Btu/h	W/W	EER						

Commercial Series

220-240V~50Hz R404A M/HBP

NE	NE6210CK	2/5	9.0	F	CSIR	1250	1075	4265	1.80	6.14	1025	882	3497	1.60	5.47		75	CCC CE	CURRENT	Cu	200
NE	NE6213CK	3/5	12.0	F	CSIR	1750	1505	5971	1.80	6.14	1435	1234	4896	1.60	5.47		75	CCC CE	CURRENT	Cu	206
NCT	NCT6228CK1	11/4	23.6	F	CSR	3320	2855	11328	2.00	6.82	2722	2341	9289	1.78	6.07	25	100	CCC	POTENTIAL	Al	278
NCT	NCT6240CK	13/4	34.6	F	CSR	4800	4128	16378	2.10	7.17	3936	3385	13430	1.87	6.38	25	100	CCC	POTENTIAL	Cu	278

220-240V~50Hz R404A LBP

L	LG68CK	3/8	6.8	F	CSIR	350	301	1194	1.30	4.44	263	226	898	1.01	3.45		75	CCC/CE	CURRENT	Cu	175
NE	NE2150CK	1/2	12.0	F	CSR	600	516	2047	1.25	4.27	451	388	1539	0.97	3.32	6	75	CCC	CURRENT	Cu	200
NE	NE2170CK	3/4	13.5	F	CSR	700	602	2388	1.25	4.27	526	453	1796	0.97	3.32	6	75	CCC/VDE	CURRENT	Cu	200
NE	NE2178CK	1	16.7	F	CSR	850	731	2900	1.30	4.44	639	550	2181	1.01	3.45	15	75	CCC	CURRENT	Cu	200
NCT	NCT2176CK1	1	23.5	F	CSR	950	817	3241	1.15	3.92	714	614	2437	0.89	3.05	25	100	CCC	POTENTIAL	Al	278
NCT	NCT2195CK	1-1/2	31.2	F	CSR	1100	946	3753	1.15	3.92	827	711	2822	0.89	3.05	25	100	CCC	POTENTIAL	Cu	264
NCT	NCT2212CK	1-3/4	34.6	F	CSR	1400	1204	4777	1.20	4.09	1053	905	3592	0.93	3.19	25	100		POTENTIAL	Cu	264

Compressor Dimensions

VSC Series

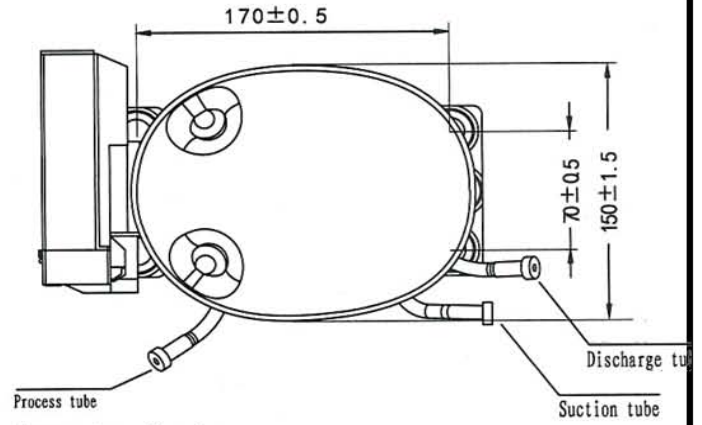
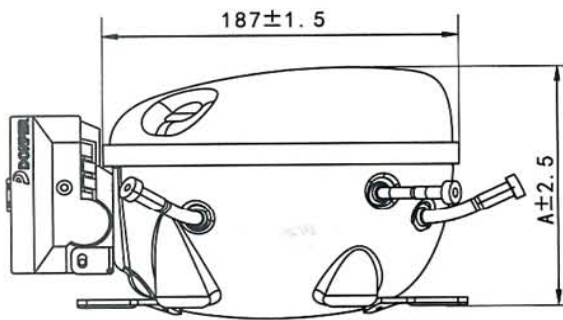

VFL Inverter Series

Suction tube and process tube can't be exchanged.

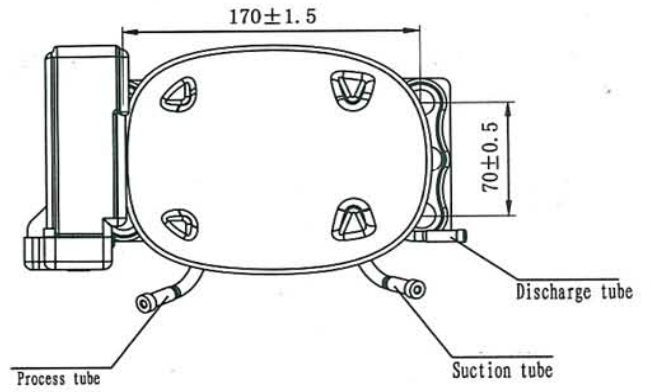
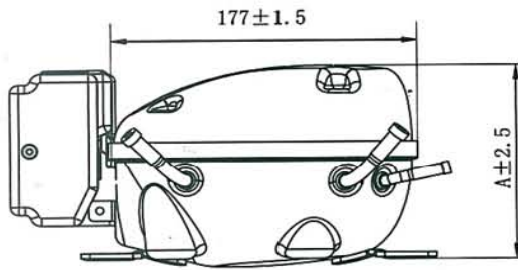

VFA Inverter Series

Suction tube and process tube can't be exchanged.

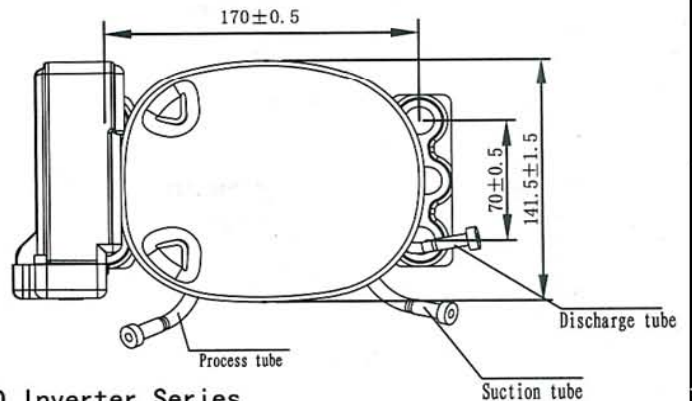
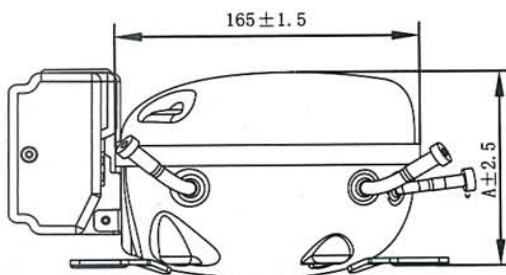

VD Inverter Series

Suction tube and process tube can't be exchanged.

C Series

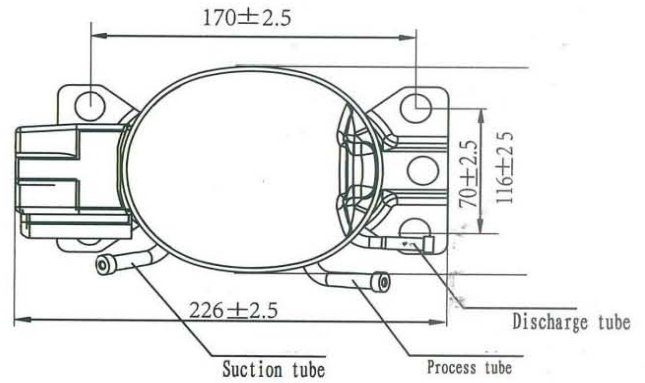
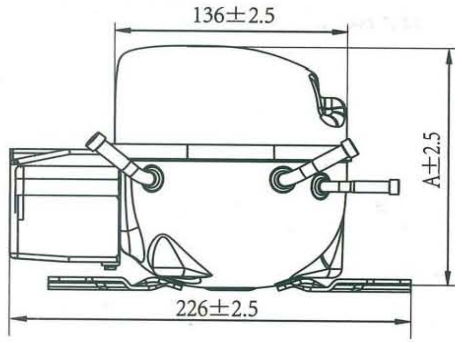

Suction tube and process tube can't be exchanged.

D Series

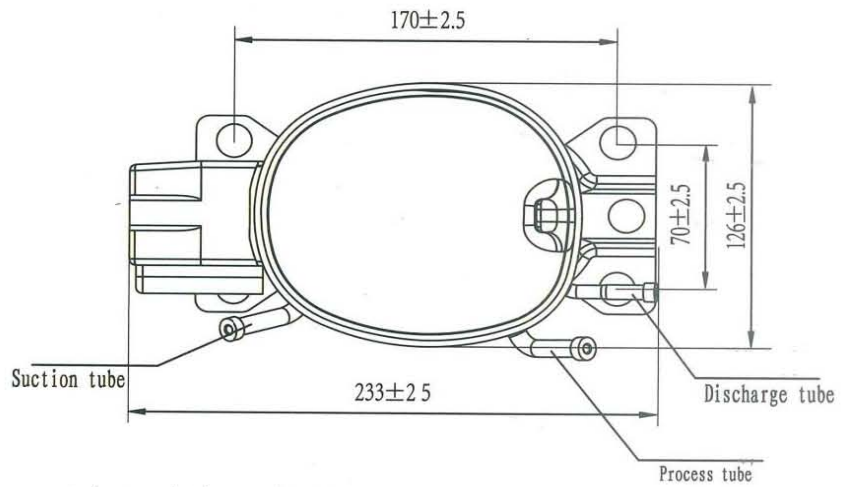
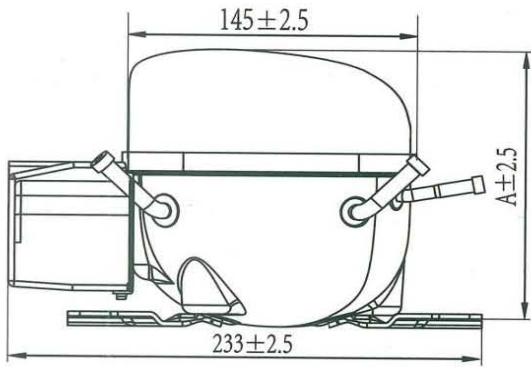

Suction tube and process tube can't be exchanged.

A Series

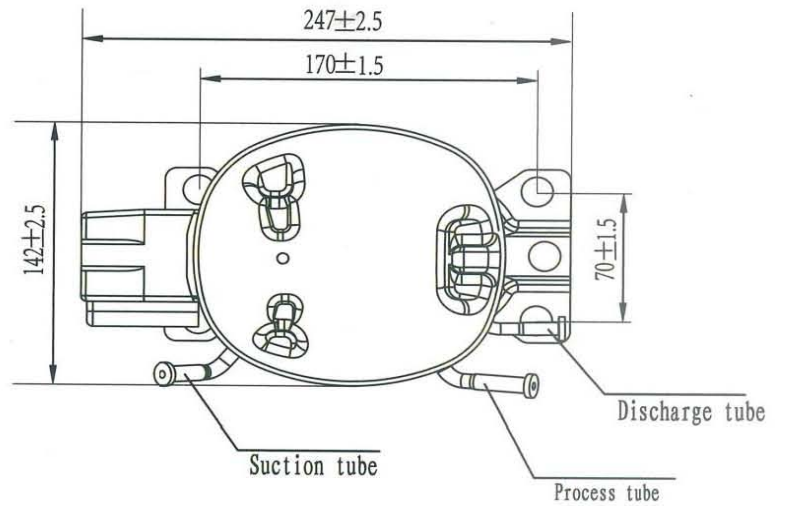
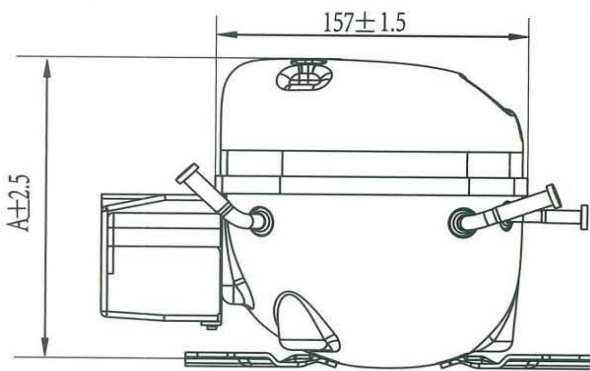

Suction tube and process tube can't be exchanged.

S Series

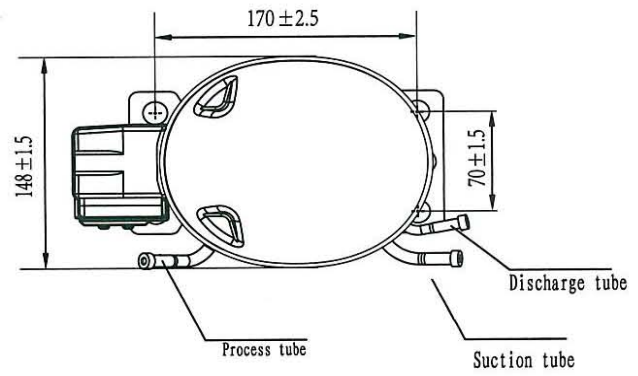
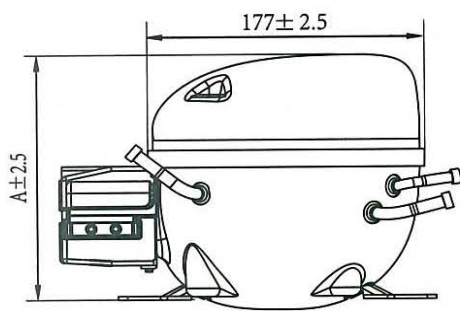

Suction tube and process tube can't be exchanged.

L Series

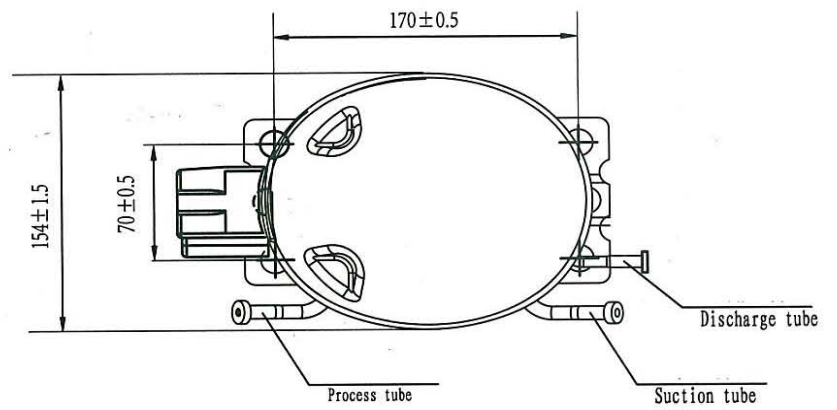
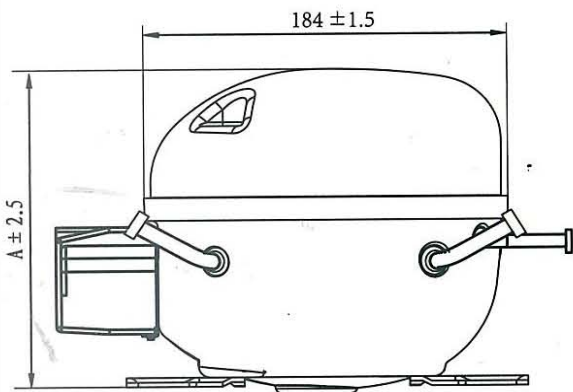

Suction tube and process tube can't be exchanged.

VC Series

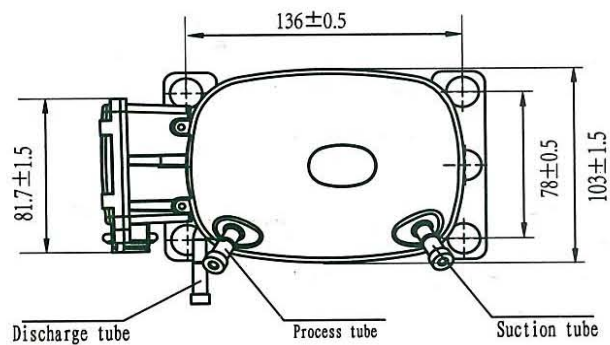
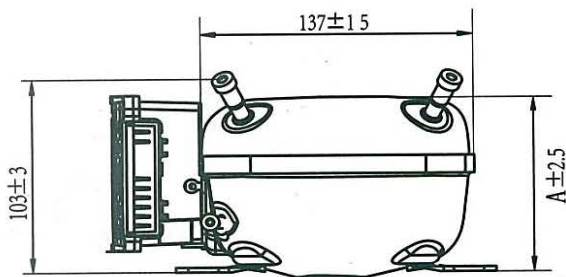

VC Inverter Series

Suction tube and process tube can't be exchanged.

K Series

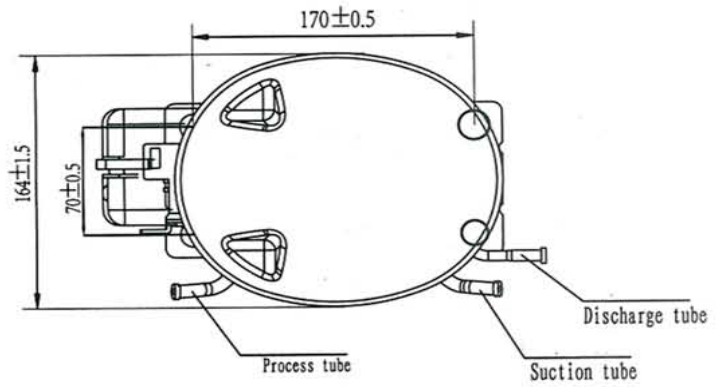
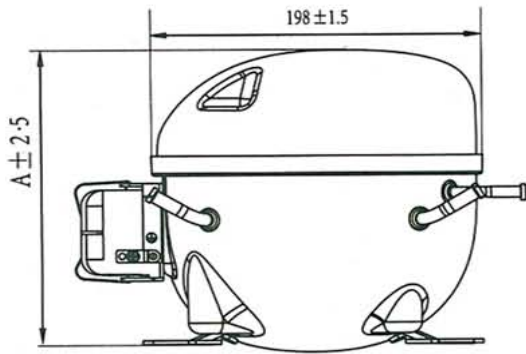

Suction tube and process tube can't be exchanged.

NE Series

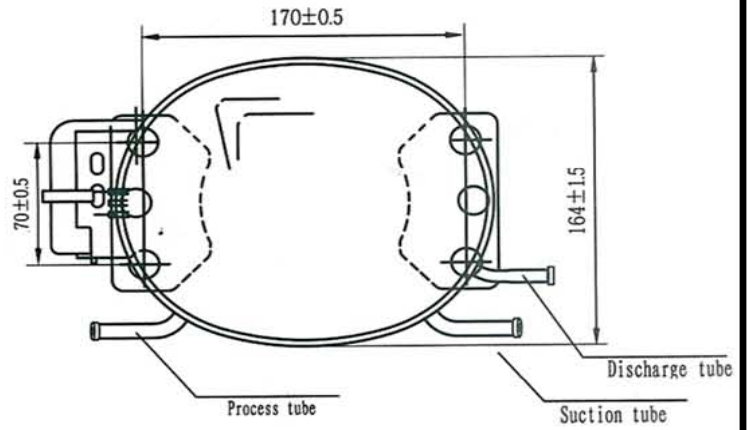
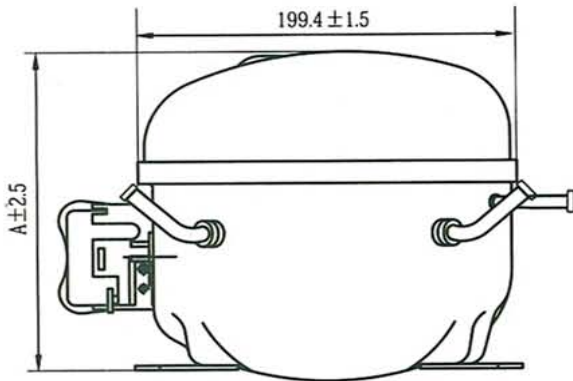

Suction tube and process tube can't be exchanged.

NCT Series

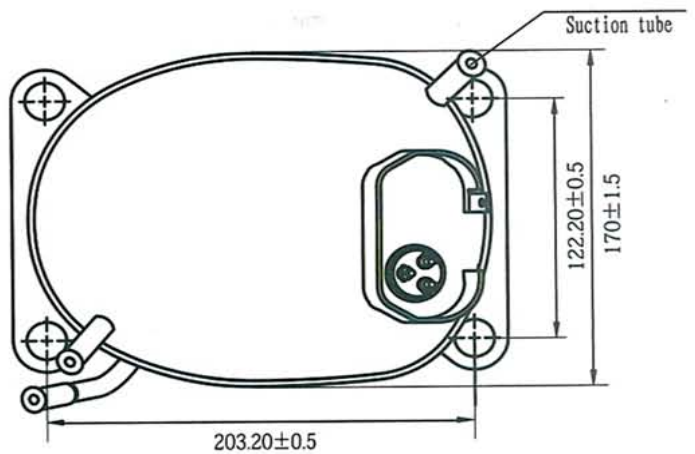
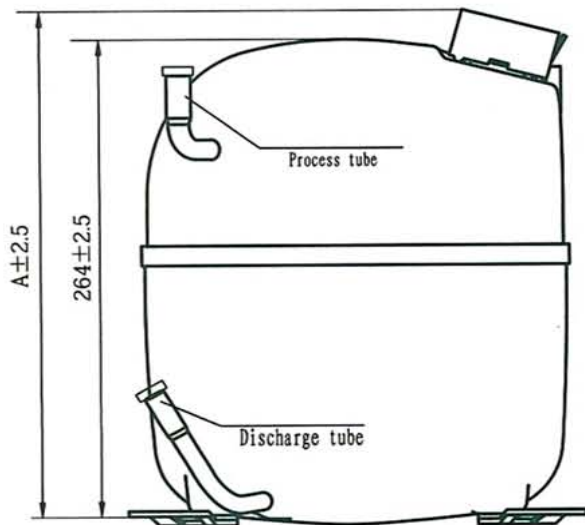

Suction tube and process tube can't be exchanged.

Electrical Wiring Diagram

RSIR

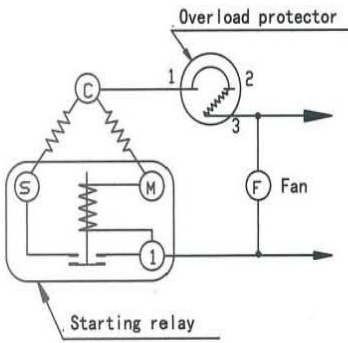

RSIR (PTC)

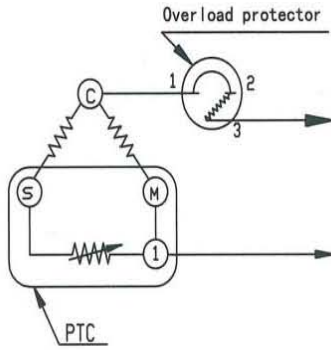

RSCR

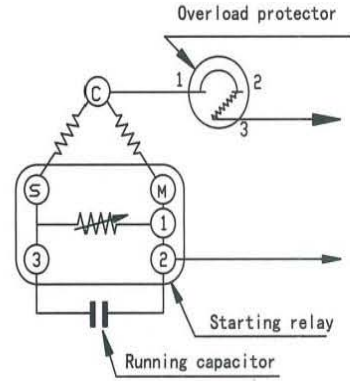

CSIR

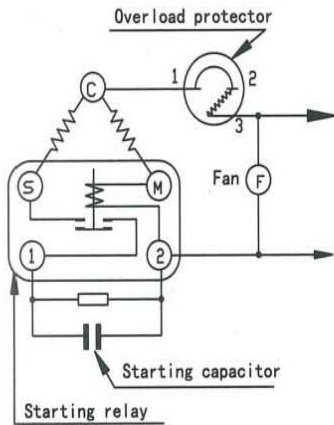

CSR

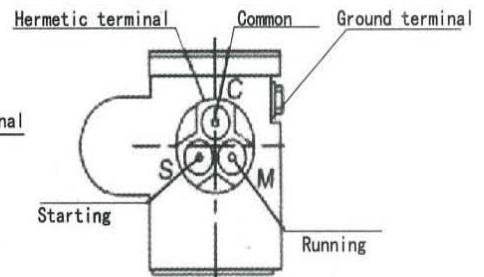
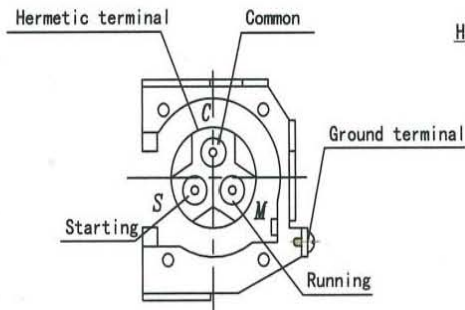
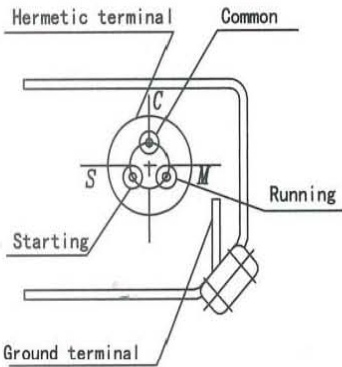
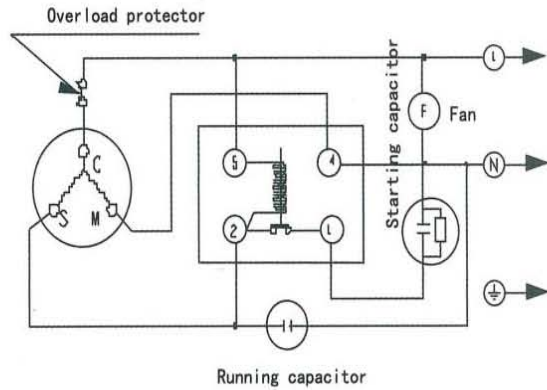

**INVOTECH
SCROLL**



R410a
R404a
R407c
R448
R449

**ON-OFF
INVERTER**

HIGHLY ROTARY

**ON-OFF
INVERTER**



R134a/R410a/R290/R32

MINI 12V-24V



ROTARY R290

ROTARY R290/R134a



**ON-OFF
INVERTER**



**ON-OFF
INVERTER**

**MINI
12V-24V**

MINI CHILLER

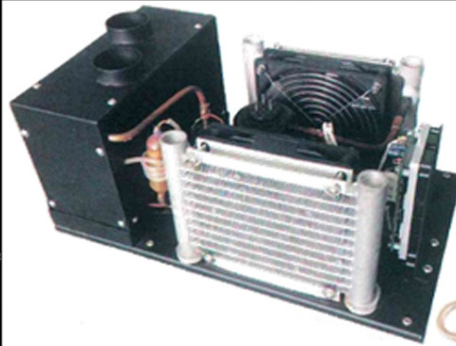

CONDENSING UNITS

**ON-OFF
INVERTER DC**



HORIZONTAL AIRCOOLED CONDENSING UNIT



**RANCO
REVERSING VALVES**



PRESSURE SWITCHES

BALL VALVES



**CE
RoHS**

CHECK VALVES



**CE
RoHS**

ROTOLOCK VALVES



VIBRATION ELIMINATOR

**CE
RoHS**

A/C VALVES

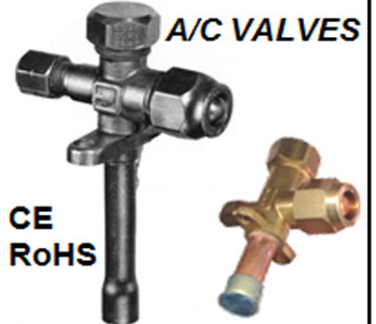

**CE
RoHS**



**CE
RoHS**

EC MOTOR



**CE
RoHS**

AXIAL FANS



R32

VACUUM PUMPS/



**EQUIPMENTS
AND TOOLS**

*KLIMAX SYSTEM
RECONA
COOL CLIMA*



*COMPRESSOR SPECIALIST
HVAC DIVISION*

VIA ERBA, 98 - 20037 PADERNO DUGNANO (MILANO)

Tel. +39 02 66304888

www.namasrl.eu - sales@namasrl.eu account@namasrl.eu