

Maximizing Power of Innovation and Creativity

COMPRESSOR

Hermetic

Model Identification

DC HEL23YG - 3
 110V 60Hz R134a
 LRA 19 THERMALLY PROTECTED RoHS
 DAEWOO ELECTRONICS Corp.
 MADE IN KOREA

 HEL23YG-3 C128130001

H E L 23 YG - 3 B
 ① ② ③ ④ ⑤ ⑥ ⑦

NO	CONTENTS	
①	Refrigerant	H : R134a I : R600a No marking : R12
②	Motor type	PTC
		C-relay
	100V Series	F : RSIR E : RSCR C : CSIR B : CSR
	220V Series	S : RSIR P : RSCR K : CSIR D : CSR
100V Series	R : RSIR N : CSIR	
220V Series	T : RSIR G : CSIR	
③	Application	L : L B P H : H B P
④	Grade of Cooling Capacity	(reference : table of capacity range)
⑤	Series name	JE Y YE YH YG
⑥	Voltage & Frequency	No marking : 100V 50/60Hz
		1 : 110-115V 60Hz
		2 : 127V 60Hz
		3 : 110V 60Hz
		4 : 220V 60Hz
5 : 220-240V 50Hz		
6 : 115-127V 60Hz		
7 : 220-240V 50Hz / 220V 60Hz		
8 : 220-240V 50Hz / 220V 60Hz		
9 : 110V 50Hz		
⑦	Improvedata order	

DC JX51LHP4
 220V 60Hz R134a
 LRA 5.1 THERMALLY PROTECTED RoHS
 ZE07003-9002
 DAEWOO ELECTRONICS Corp.
 MADE IN KOREA

 JX51LHP4 C128130001

JX 51 L H P - 4 B
 ① ② ③ ④ ⑤ ⑥ ⑦

DC NW99LIP5
 220-240V 50Hz R600a
 LRA 3.7 THERMALLY PROTECTED RoHS
 DAEWOO ELECTRONICS Corp.
 MADE IN KOREA

 NW99LIP5 C128130001



NO	CONTENTS	
①	Series name	DS DH DM JX WX YX NW
②	Displacement	x10 (cc/rev)
③	Application	L : L B P
		H : H B P
④	Refrigerant	H : R134a
		I : R600a
		C : R12
⑤	Motor type	PTC
		C-relay
	100V Series	F : RSIR E : RSCR C : CSIR B : CSR
	220V Series	S : RSIR P : RSCR K : CSIR D : CSR
100V Series	R : RSIR N : CSIR	
220V Series	T : RSIR G : CSIR	
⑥	Voltage & Frequency	No marking : 100V 50/60Hz
		1 : 110-115V 60Hz
		2 : 127V 60Hz
		3 : 110V 60Hz
		4 : 220V 60Hz
5 : 220-240V 50Hz		
6 : 115-127V 60Hz		
7 : 220-240V 50Hz / 220V 60Hz		
8 : 220-240V 50Hz / 220V 60Hz		
9 : 110V 50Hz		
⑦	Improvedata order	

Cooling Capacity

(ASHRAE, 60Hz)

Refrigerant Application	Series	[kcal/h]							
		50	100	150	200	250	300	350	
R134a (LBP)	DS	37	75						
	WX	29	80						
	Y	35	101						
	JE		93	165					
	JX		89	176					
	YH		115	231					
	YX		125	175					
	YG		146	283					
	YE		151	273					
	DH		161	309					
	DM			234	290				
	NW		125	302					

Units & Conversions

Multiply	By	To Obtain
kcal/h	1.163	W
kcal/h	3.968	Btu/h
EER	0.293	COP
To Obtain	By	Divide

R134a LBP

100V 50/60Hz

Remark (*) means under development mode

Series	Model	Displacement [cc/rev]	Consumption Power [W]	Cooling Capacity			Efficiency			Motor Type	Cooling Type	Net Weight [kg]	Oil Qty. [cc]
				kcal/h	Watt	Btu/h	EFF kcal/Wh	COP W/W	EER Btu/Wh				
DS	DS25LHF0	2.54	71	50	58	198	0.70	0.82	2.79	RSIR	ST	6.0	180
			73	60	70	238	0.82	0.96	3.26				
	DS30LHF0	3.06	85	60	70	238	0.71	0.82	2.80	RSIR	ST	6.0	180
			85	70	81	278	0.82	0.96	3.27				
WX	WX20LHF0T	2.01	70	30	35	119	0.43	0.50	1.70	RSIR	ST	5.9	180
			63	35	41	139	0.56	0.65	2.20				
	WX24LHF0	2.54	69	40	47	159	0.58	0.67	2.30	RSIR	ST	5.9	180
			70	50	58	198	0.71	0.83	2.83				
	WX24LHF0T	2.54	72	40	47	159	0.56	0.65	2.20	RSIR	ST	5.9	180
			70	50	58	198	0.71	0.83	2.83				
	WX24LHF0TB	2.54	72	40	47	159	0.56	0.65	2.20	RSIR	ST	5.9	180
			70	50	58	198	0.71	0.83	2.83				
	WX24LHF0W-K	2.54	75	40	47	159	0.53	0.62	2.12	RSIR	ST	5.9	180
			76	50	58	198	0.66	0.77	2.61				
	WX30LHF0	3.06	80	60	70	238	0.75	0.87	2.98	RSIR	ST	5.9	180
			88	70	81	278	0.80	0.93	3.16				
	WX30LHF0T	3.06	105	55	64	218	0.52	0.61	2.08	RSIR	ST	5.9	180
			98	65	76	258	0.66	0.77	2.63				
	WX30LHF0W-K	3.06	102	60	70	238	0.59	0.68	2.33	RSIR	ST	5.9	180
			96	70	81	278	0.73	0.85	2.89				
Y	HFL5Y	2.29	65	35	41	139	0.54	0.63	2.14	RSIR	ST	6.7	230
			69	45	52	179	0.65	0.76	2.59				
	HFL7Y	2.65	83	50	58	198	0.60	0.70	2.39	RSIR	ST	6.7	230
			85	60	70	238	0.71	0.82	2.80				
HFL9Y	3.43	80	55	64	218	0.69	0.80	2.73	RSIR	ST	6.7	230	
		92	70	81	278	0.76	0.88	3.02					
HFL11Y	4.51	112	80	93	317	0.71	0.83	2.83	RSIR	ST	7.0	230	
		115	95	110	377	0.83	0.96	3.28					
JE	HEL15JE	5.12	119	110	128	437	0.92	1.08	3.67	RSCR	ST/FC	7.7	230
			131	135	157	536	1.03	1.20	4.09				
JX	JX46LHF0	4.62	108	106	123	421	0.98	1.14	3.89	RSIR	ST/FC	8.0	230
			122	128	149	508	1.05	1.22	4.16				
	JX51LHF0	5.12	110	120	140	476	1.09	1.27	4.33	RSIR	ST/FC	8.3	230
			133	150	174	595	1.13	1.31	4.48				
	JX58LHC0	5.84	147	140	163	556	0.95	1.11	3.78	CSIR	ST/FC	8.3	230
			152	170	198	675	1.12	1.30	4.44				
	JX58LHE0	5.84	132	140	163	556	1.06	1.23	4.21	RSCR	ST/FC	8.3	230
			143	170	198	675	1.19	1.38	4.72				
JX58LHF0	5.84	146	140	163	556	0.96	1.12	3.81	RSIR	ST/FC	8.3	230	
		151	170	198	675	1.13	1.31	4.47					
YH	HEL15YH	5.12	101	115	134	456	1.14	1.32	4.52	RSCR	ST/OC/FC	9.2	290
			119	140	163	556	1.18	1.37	4.67				
	HEL17YH	5.55	117	130	151	516	1.11	1.29	4.41	RSCR	ST/OC/FC	9.2	290
			133	155	180	615	1.17	1.36	4.62				
HEL21YH	6.73	117	130	151	516	1.11	1.29	4.41	RSCR	ST/OC/FC	9.2	290	
		132	154	179	611	1.17	1.36	4.63					
YX	YX51LHE0	5.12	96	120	140	476	1.25	1.45	4.96	RSCR	ST/OC/FC	8.8	290
			114	146	170	579	1.28	1.49	5.08				
	YX58LHE0	5.84	116	145	169	575	1.25	1.45	4.96	RSCR	ST/OC/FC	8.8	290
136			175	204	694	1.29	1.50	5.11					

R134a LBP

100V 50 / 60Hz

Remark (*) means under development mode

Series	Model	Displacement [cc/rev]	Consumption Power [W]	Cooling Capacity			Efficiency			Motor Type	Cooling Type	Net Weight [kg]	Oil Qty. [cc]
				kcal/h	Watt	Btu/h	EFF	COP	EER				
							kcal/Wh	W/W	Btu/Wh				
YE	HBL23YE	7.03	155	160	186	635	1.03	1.20	4.10	CSR	ST/OC/FC	9.3	290
			170	190	221	754	1.12	1.30	4.44				
	HBL25YE	7.68	192	198	230	786	1.03	1.20	4.09	CSR	ST/OC/FC	9.5	290
			188	213	248	845	1.13	1.32	4.50				
	HCL25YE	7.68	222	182	212	722	0.82	0.95	3.25	CSIR	ST/OC/FC	9.5	290
			214	217	252	861	1.01	1.18	4.02				
	HBL27YE	8.69	248	198	230	786	0.80	0.93	3.17	CSR	ST/OC/FC	9.5	290
			217	236	274	937	1.09	1.26	4.32				
	HCL27YE	8.69	236	201	234	798	0.85	0.99	3.38	CSIR	ST/OC/FC	9.5	290
			235	238	277	944	1.01	1.18	4.02				
YG	HEL21YG	6.73	149	150	174	595	1.01	1.17	3.99	RSCR	ST/OC/FC	9.5	290
			169	185	215	734	1.09	1.27	4.34				
DM	DM99LHB0	9.92	248	234	272	929	0.94	1.10	3.74	CSR	FC	9.7	290
			236	278	323	1103	1.18	1.37	4.67				

Test Condition(ASHRAE) LBP

1. Evaporating temperature : -23.3 °C (-10 °F)
2. Condensing temperature : 54.4 °C (130 °F)
3. Ambient temperature : 32.2 °C (90 °F)
4. Gas superheated to : 32.2 °C (90 °F)
5. Liquid subcooled to : 32.2 °C (90 °F)

Motor Type

1. RSIR : Resistance Start Induction Run
2. RSCR : Resistance Start Capacitor Run
3. CSIR : Capacitor Start Induction Run
4. CSR : Capacitor Start Capacitor Run

Compressor Cooling

1. ST : Static Cooling
2. OC : Oil Cooling
3. FC : Fan Cooling

R134a HBP

100V 50 / 60Hz

Remark (*) means under development mode

Series	Model	Displacement [cc/rev]	Consumption Power [W]	Cooling Capacity			Efficiency			Motor Type	Cooling Type	Net Weight [kg]	Oil Qty. [cc]
				kcal/h	Watt	Btu/h	EFF	COP	EER				
							kcal/Wh	W/W	Btu/Wh				
Y	HFH7Y	2.65	132	200	233	794	1.52	1.76	6.01	RSIR	ST	6.7	230
			160	235	273	933	1.47	1.71	5.83				
YE	HBH23YE	7.03	280	560	651	2222	2.00	2.33	7.94	CSR	OC/FC	9.3	290
			350	680	791	2698	1.94	2.26	7.71				
	HCH27YE	8.70	390	685	797	2718	1.76	2.04	6.97	CSIR	OC/FC	9.5	290
			470	820	954	3254	1.74	2.03	6.92				
DM	DM99HHB0	9.92	410	850	989	3373	2.07	2.41	8.23	CSR	FC	9.7	290
			486	990	1151	3929	2.04	2.37	8.08				

R134a HBP

110-115V 60Hz

Remark (*) means under development mode

Series	Model	Displacement [cc/rev]	Consumption Power [W]	Cooling Capacity			Efficiency			Motor Type	Cooling Type	Net Weight [kg]	Oil Qty. [cc]
				kcal/h	Watt	Btu/h	EFF	COP	EER				
							kcal/Wh	W/W	Btu/Wh				
WX	WX35HHF1W	3.50	220	310	361	1230	1.41	1.64	5.59	RSIR	ST	5.9	180
Y	HFH9Y-1	3.43	168	300	349	1190	1.79	2.08	7.09	RSIR	ST	6.7	230
	HFH11Y-1	4.51	233	415	483	1647	1.78	2.07	7.07	RSIR	ST	7.0	230
	HCH11Y-1	4.51	230	415	483	1647	1.80	2.10	7.16	CSIR	ST	7.0	230
JE	HFH15JE-1	5.12	275	475	552	1885	1.73	2.01	6.85	RSIR	ST	7.7	230
	HFH17JE-1	5.55	290	520	605	2064	1.79	2.09	7.12	RSIR	ST	7.7	230
	HFH19JE-1	5.84	300	540	628	2143	1.80	2.09	7.14	RSIR	ST	8.2	230
YE	HCH21YE-1	6.73	344	655	762	2599	1.90	2.21	7.56	CSIR	ST/OC/FC	9.0	290
	HCH23YE-1	7.03	350	680	791	2698	1.94	2.26	7.71	CSIR	ST/OC/FC	9.3	290
	HCH25YE-1	7.68	395	750	872	2976	1.90	2.21	7.53	CSIR	ST/OC/FC	9.5	290
	HCH27YE-1	8.69	470	820	953	3254	1.74	2.03	6.92	CSIR	ST/OC/FC	9.5	180
YG	HCH30YG-1	9.92	550	945	1099	3750	1.72	2.00	6.82	CSIR	ST/OC/FC	9.5	180

Test Condition(ASHRAE) HBP

1. Evaporating temperature : 7.2 °C (45 °F)
2. Condensing temperature : 54.4 °C (130 °F)
3. Ambient temperature : 35.0 °C (95 °F)
4. Gas superheated to : 46.1 °C (115 °F)
5. Liquid subcooled to : 35.0 °C (95 °F)

Motor Type

1. RSIR : Resistance Start Induction Run
2. RSCR : Resistance Start Capacitor Run
3. CSIR : Capacitor Start Induction Run
4. CSR : Capacitor Start Capacitor Run

Compressor Cooling

1. ST : Static Cooling
2. OC : Oil Cooling
3. FC : Fan Cooling

R134a HBP

220V 60Hz

Remark (*) means developing model

Series	Model	Displacement [cc/rev]	Consumption Power [W]	Cooling Capacity			Efficiency			Motor Type	Cooling Type	Net Weight [kg]	Oil Qty. [cc]
				kcal/h	Watt	Btu/h	EFF	COP	EER				
							kcal/Wh	W/W	Btu/Wh				
WX	WX24HHS4W	2.54	152	220	256	873	1.45	1.68	5.74	RSIR	ST	5.9	180
	WX30HHS4W	3.06	186	265	308	1052	1.42	1.66	5.65	RSIR	ST	5.9	180
	WX35HHS4W	3.50	208	310	361	1230	1.49	1.73	5.91	RSIR	ST	6.3	180
	WX35HHS4WF	3.50	208	310	361	1230	1.49	1.73	5.91	RSIR	ST	6.3	180
	WX35HHS4WP	3.50	208	310	361	1230	1.49	1.73	5.91	RSIR	ST	6.3	180
Y	HPH9Y-4	3.43	170	300	349	1190	1.76	2.05	7.00	RSCR	ST	6.7	230
JE	HPH13JE-4	4.62	218	445	518	1766	2.04	2.37	8.10	RSCR	OC	7.0	230
JX	JX46HHS4	4.62	237	455	529	1806	1.92	2.23	7.62	RSIR	ST/FC	8.0	230
YX	YX58HHP4	5.80	260	680	791	2698	2.62	3.04	10.38	RSCR	ST/FC	9.8	290
YE	HDH25YE-4	7.68	367	750	872	2976	2.04	2.38	8.11	CSR	ST/OC/FC	9.5	290
	HSH28YE-4	8.69	463	830	965	3294	1.79	2.08	7.11	RSIR	ST/OC/FC	9.5	290
	HDH28YE-4-K	8.69	467	830	965	3294	1.78	2.07	7.05	CSR	ST/OC/FC	9.5	290
	HPH28YE-4-K	8.69	471	830	965	3294	1.76	2.05	6.99	RSCR	ST/OC/FC	9.5	290
	HGH30YE-4	9.92	535	920	1070	3651	1.72	2.00	6.82	CSIR	ST/OC/FC	9.5	290
	HKH30YE-4	9.92	540	920	1070	3651	1.70	1.98	6.76	CSIR	ST/OC/FC	9.5	290
YG	HKH30YG-4	9.92	545	950	1105	3770	1.74	2.03	6.92	CSIR	ST/OC/FC	9.5	290
DH	DH90HHP4	8.93	490	900	1047	3571	1.84	2.14	7.29	RSIR	FC	10.4	290
	DH99HHP4	9.92	510	950	1105	3770	1.86	2.17	7.39	RSIR	FC	10.4	290
DM	DM90HHS4	8.93	510	900	1047	3571	1.76	2.05	7.00	RSIR	FC	9.7	290
	DM99HHS4	9.92	533	950	1105	3770	1.78	2.07	7.07	RSIR	FC	9.7	290

R134a HBP

220-240V 50Hz

Remark (*) means developing model

Series	Model	Displacement [cc/rev]	Consumption Power [W]	Cooling Capacity			Efficiency			Motor Type	Cooling Type	Net Weight [kg]	Oil Qty. [cc]
				kcal/h	Watt	Btu/h	EFF	COP	EER				
							kcal/Wh	W/W	Btu/Wh				
WX	WX35HHS5W	3.51	188	260	302	1032	1.38	1.61	5.49	RSIR	ST	6.3	180
Y	HSH9Y-5	3.43	157	230	267	913	1.46	1.70	5.81	RSIR	ST	6.7	230
	HSH11Y-5	4.51	201	330	384	1310	1.64	1.91	6.52	RSIR	ST	7.0	230
JE	HSH15JE-5	5.12	210	400	465	1587	1.90	2.22	7.56	RSIR	ST	7.7	230
	HSH17JE-5	5.55	247	430	500	1706	1.74	2.02	6.91	RSIR	ST	7.7	230
	HSH19JE-5	5.84	247	450	523	1786	1.82	2.12	7.23	RSIR	ST	8.2	230
YE	HGH23YE-5	7.03	300	590	686	2341	1.97	2.29	7.80	CSIR	OC/FC	9.3	290
	HGH25YE-5	7.68	335	630	733	2500	1.88	2.19	7.46	CSIR	OC/FC	9.5	290
	HSH25YE-5	7.68	326	630	733	2500	1.93	2.25	7.67	RSIR	OC/FC	9.5	290
	HKH27YE-5	8.69	370	710	826	2817	1.92	2.23	7.61	CSIR	OC/FC	9.5	290
	HSH27YE-5	8.69	377	710	826	2817	1.88	2.19	7.47	RSIR	OC/FC	9.5	290
	HSH30YE-5	9.92	426	780	907	3095	1.83	2.13	7.27	RSIR	OC/FC	9.5	290
YG	HKH30YG-5	9.92	470	800	930	3175	1.70	1.98	6.75	CSIR	OC/FC	9.5	290
RM	RM99HHG5	9.92	435	840	977	3333	1.93	2.25	7.66	CSIR	FC	9.7	290
DH	DH120HHG5	12.0	600	1030	1198	4087	1.72	2.00	6.81	CSIR	FC	9.7	290
DM	DM90HHS5	8.93	380	760	884	3016	2.00	2.33	7.94	RSIR	FC	9.7	290
	DM99HHG5	9.92	435	840	977	3333	1.93	2.25	7.66	CSIR	FC	9.7	290
	DM99HHK5	9.92	435	840	977	3333	1.93	2.25	7.66	CSIR	FC	9.7	290
	DM99HHS5	9.92	430	840	977	3333	1.95	2.27	7.75	RSIR	FC	9.7	290

Test Condition(ASHRAE) HBP

1. Evaporating temperature : 7.2 °C (45 °F)
2. Condensing temperature : 54.4 °C (130 °F)
3. Ambient temperature : 35.0 °C (95 °F)
4. Gas superheated to : 46.1 °C (115 °F)
5. Liquid subcooled to : 35.0 °C (95 °F)

Motor Type

1. RSIR : Resistance Start Induction Run
2. RSCR : Resistance Start Capacitor Run
3. CSIR : Capacitor Start Induction Run
4. CSR : Capacitor Start Capacitor Run

Compressor Cooling

1. ST : Static Cooling
2. OC : Oil Cooling
3. FC : Fan Cooling

R134a LBP

110V 50Hz

Remark (*) means under development mode

Series	Model	Displacement [cc/rev]	Consumption Power [W]	Cooling Capacity			Efficiency			Motor Type	Cooling Type	Net Weight [kg]	Oil Qty. [cc]
				kcal/h	Watt	Btu/h	EFF	COP	EER				
							kcal/Wh	W/W	Btu/Wh				
DS	DS25LHF9	2.54	68	50	58	198	0.74	0.86	2.92	RSIR	ST	6.0	180
JE	HEL19JE-9	5.84	135	135	157	536	1.00	1.16	3.97	RSCR	ST/FC	8.2	230
YG	HEL23YG-9	7.03	160	160	186	635	1.00	1.16	3.97	RSCR	ST/OC/FC	9.3	290
	HFL25YG-9A	7.68	165	180	209	714	1.09	1.27	4.33	RSIR	ST/OC/FC	9.3	290
	* HCL27YG-9	8.69	230	205	238	814	0.89	1.04	3.54	CSIR	ST/OC/FC	9.5	290
	HBL30YG-9	9.92	284	235	273	933	0.83	0.96	3.28	CSR	ST/OC/FC	9.5	290

Test Condition(ASHRAE) LBP

1. Evaporating temperature : -23.3 °C (-10 °F)
2. Condensing temperature : 54.4 °C (130 °F)
3. Ambient temperature : 32.2 °C (90 °F)
4. Gas superheated to : 32.2 °C (90 °F)
5. Liquid subcooled to : 32.2 °C (90 °F)

Motor Type

1. RSIR : Resistance Start Induction Run
2. RSCR : Resistance Start Capacitor Run
3. CSIR : Capacitor Start Induction Run
4. CSR : Capacitor Start Capacitor Run

Compressor Cooling

1. ST : Static Cooling
2. OC : Oil Cooling
3. FC : Fan Cooling

R134a LBP

110V 60Hz

Remark (*) means under development mode

Series	Model	Displacement [cc/rev]	Consumption Power [W]	Cooling Capacity			Efficiency			Motor Type	Cooling Type	Net Weight [kg]	Oil Qty. [cc]
				kcal/h	Watt	Btu/h	EFF	COP	EER				
							kcal/Wh	W/W	Btu/Wh				
Y	HEL11Y-3	4.51	104	95	110	377	0.91	1.06	3.62	RSCR	ST	6.7	230
JE	HEL13JE-3	4.62	114	120	140	476	1.05	1.22	4.18	RSCR	ST/FC	7.4	230
	HEL15JE-3	5.12	128	135	157	536	1.05	1.23	4.19	RSCR	ST/FC	7.7	230
	HEL19JE-3	5.84	144	155	180	615	1.08	1.25	4.27	RSCR	ST/FC	8.2	230
	JX	JX51LHE3	5.12	132	150	174	595	1.14	1.32	4.51	RSCR	ST/FC	8.3
	JX58LHE3	5.84	143	170	198	675	1.19	1.38	4.72	RSCR	ST/FC	8.3	230
YH	HEL26YH-3	8.25	195	235	273	933	1.21	1.40	4.78	RSCR	ST/FC	9.2	290
YX	YX58LHE3	5.84	137	175	204	694	1.28	1.49	5.07	RSCR	ST/FC	9.5	290
YG	HEL21YG-3	6.73	166	185	215	734	1.11	1.30	4.42	RSCR	ST/OC/FC	9.0	290
	HCL23YG-3	7.03	180	200	233	794	1.11	1.29	4.41	CSIR	ST/OC/FC	9.3	290
	HEL23YG-3	7.03	179	200	233	794	1.12	1.30	4.43	RSCR	ST/OC/FC	9.3	290
	HBL25YG-3	7.68	197	215	250	853	1.09	1.27	4.33	CSR	ST/OC/FC	9.5	290
	HBL27YG-3	8.69	246	250	291	992	1.02	1.18	4.03	CSR	ST/OC/FC	9.5	290
YE	HBL23YE-3	7.03	181	190	221	754	1.05	1.22	4.17	CSR	ST/OC/FC	9.3	290
	HCL23YE-3	7.03	193	190	221	754	0.98	1.14	3.91	CSIR	ST/OC/FC	9.3	290
	HBL27YE-3	8.69	238	240	279	952	1.01	1.17	4.00	CSR	ST/OC/FC	9.5	290

Test Condition(ASHRAE) LBP

1. Evaporating temperature : -23.3 °C (-10 °F)
2. Condensing temperature : 54.4 °C (130 °F)
3. Ambient temperature : 32.2 °C (90 °F)
4. Gas superheated to : 32.2 °C (90 °F)
5. Liquid subcooled to : 32.2 °C (90 °F)

Motor Type

1. RSIR : Resistance Start Induction Run
2. RSCR : Resistance Start Capacitor Run
3. CSIR : Capacitor Start Induction Run
4. CSR : Capacitor Start Capacitor Run

Compressor Cooling

1. ST : Static Cooling
2. OC : Oil Cooling
3. FC : Fan Cooling

R134a LBP

110-115V 60Hz

Remark (*) means under development model

Series	Model	Displacement [cc/rev]	Consumption Power [W]	Cooling Capacity			Efficiency			Motor Type	Cooling Type	Net Weight [kg]	Oil Qty. [cc]
				kcal/h	Watt	Btu/h	EFF	COP	EER				
							kcal/Wh	W/W	Btu/Wh				
DS	DS22LHF1	2.18	55	45	52	179	0.82	0.95	3.25	RSIR	ST	6.0	180
	DS25LHF1	2.54	71	60	70	238	0.85	0.98	3.35	RSIR	ST	6.0	180
	DS30LHF1	3.06	85	70	81	278	0.82	0.96	3.27	RSIR	ST	6.0	180
WX	WX24LHF1	2.54	71	50	58	198	0.70	0.82	2.79	RSIR	ST	5.9	180
	WX24LHF1T	2.54	76	50	58	198	0.66	0.76	2.61	RSIR	ST	5.9	180
	WX24LHF1TF	2.54	75	50	58	198	0.67	0.78	2.65	RSIR	ST	5.9	180
	WX24LHF1W-K	2.54	79	50	58	198	0.63	0.74	2.51	RSIR	ST	5.9	180
	WX30LHF1	3.06	83	65	76	258	0.78	0.91	3.11	RSIR	ST	5.9	180
	WX30LHF1T	3.06	103	65	76	258	0.63	0.73	2.50	RSIR	ST	5.9	180
	WX30LHF1W-K	3.06	96	65	76	258	0.68	0.79	2.69	RSIR	ST	5.9	180
Y	HFL5Y-1	2.29	68	45	52	179	0.66	0.77	2.63	RSIR	ST	6.7	230
	HFL7Y-1	2.65	87	60	70	238	0.69	0.80	2.74	RSIR	ST	6.7	230
	HEL9Y-1	3.43	77	60	70	238	0.78	0.91	3.09	RSCR	ST	6.7	230
	HFL9Y-1	3.43	86	60	70	238	0.70	0.81	2.77	RSIR	ST	6.7	230
	HFL11Y-1	4.51	125	95	110	377	0.76	0.88	3.02	RSIR	ST	6.7	230
JE	HEL13JE-1	4.62	115	120	140	476	1.04	1.21	4.14	RSCR	ST/FC	7.4	230
	HFL13JE-1	4.62	121	120	140	476	0.99	1.15	3.94	RSIR	ST/FC	7.4	230
	HFL15JE-1	5.12	147	135	157	536	0.92	1.07	3.64	RSIR	ST/FC	7.7	230
	HEL17JE-1	5.55	138	145	169	575	1.05	1.22	4.17	RSCR	ST/FC	7.7	230
	HFL17JE-1	5.55	153	145	169	575	0.95	1.10	3.76	RSIR	ST/FC	7.7	230
	HEL19JE-1	5.84	144	155	180	615	1.08	1.25	4.27	RSCR	ST/FC	8.2	230
	HFL19JE-1	5.84	181	155	180	615	0.86	1.00	3.40	RSIR	ST/FC	8.2	230
JX	JX46LHF1	4.62	129	128	149	508	0.99	1.15	3.94	RSIR	ST/FC	8.0	230
	JX51LHN1	5.12	149	142	165	563	0.95	1.11	3.78	CSIR	ST/FC	8.3	230
	JX55LHE1	5.50	142	157	183	623	1.11	1.29	4.39	RSCR	ST/FC	8.3	230
	JX58LHC1	5.80	163	170	198	675	1.04	1.21	4.14	CSIR	ST/FC	8.3	230
	JX58LHE1	5.80	140	170	198	675	1.21	1.41	4.82	RSCR	ST/FC	8.3	230
	JX58LHF1	5.80	147	170	198	675	1.16	1.34	4.59	RSIR	ST/FC	8.3	230
YH	HEL15YH-1	5.12	112	140	163	556	1.25	1.45	4.96	RSCR	ST/OC/FC	9.2	290
	HEL17YH-1	5.55	125	155	180	615	1.24	1.44	4.92	RSCR	ST/OC/FC	9.2	290
	HEL19YH-1	5.84	136	172	200	683	1.26	1.47	5.02	RSCR	ST/OC/FC	9.2	290
	HEL21YH-1	6.73	162	193	224	766	1.19	1.39	4.73	RSCR	ST/OC/FC	9.5	290
YX	YX51LHE1	5.12	117	146	170	579	1.25	1.45	4.95	RSCR	ST/OC/FC	9.0	290
	YX58LHE1	5.84	132	168	195	667	1.27	1.48	5.05	RSCR	ST/OC/FC	9.8	290
YG	HEL21YG-1	6.73	166	185	215	734	1.11	1.30	4.42	RSCR	ST/OC/FC	9.0	290
	HEL23YG-1	7.03	178	200	233	794	1.12	1.31	4.46	RSCR	ST/OC/FC	9.5	290
	HBL27YG-1	8.69	245	250	291	992	1.02	1.19	4.05	CSR	ST/OC/FC	9.5	290
YE	HBL23YE-1	7.03	180	190	221	754	1.06	1.23	4.19	CSR	ST/OC/FC	9.3	290
	HCL23YE-1	7.03	186	190	221	754	1.02	1.19	4.05	CSIR	ST/OC/FC	9.3	290
	HBL25YE-1	7.68	194	211	245	837	1.09	1.26	4.32	CSR	ST/OC/FC	9.3	290
	HEL25YE-1	7.68	209	208	242	825	1.00	1.16	3.95	RSCR	ST/OC/FC	9.5	290
	HBL27YE-1	8.69	237	240	279	952	1.01	1.18	4.02	CSR	ST/OC/FC	9.5	290
	HCL30YE-1	9.92	270	270	314	1071	1.00	1.16	3.97	CSIR	ST/OC/FC	9.5	290

Test Condition(ASHRAE) LBP

1. Evaporating temperature : -23.3 °C (-10 °F)
2. Condensing temperature : 54.4 °C (130 °F)
3. Ambient temperature : 32.2 °C (90 °F)
4. Gas superheated to : 32.2 °C (90 °F)
5. Liquid subcooled to : 32.2 °C (90 °F)

Motor Type

1. RSIR : Resistance Start Induction Run
2. RSCR : Resistance Start Capacitor Run
3. CSIR : Capacitor Start Induction Run
4. CSR : Capacitor Start Capacitor Run

Compressor Cooling

1. ST : Static Cooling
2. OC : Oil Cooling
3. FC : Fan Cooling

R134a LBP

127V 60Hz

Remark (*) means under development model

Series	Model	Displacement [cc/rev]	Consumption Power [W]	Cooling Capacity			Efficiency			Motor Type	Cooling Type	Net Weight [kg]	Oil Qty. [cc]
				kcal/h	Watt	Btu/h	EFF	COP	EER				
							kcal/Wh	W/W	Btu/Wh				
DS	DS25LHF2	2.54	82	60	70	238	0.73	0.85	2.90	RSIR	ST	6.0	180
WX	WX24LHF2	2.54	69	50	58	198	0.72	0.84	2.88	RSIR	ST	5.9	180
	WX24LHF2T	2.54	90	50	58	198	0.56	0.65	2.20	RSIR	ST	5.9	180
	WX30LHF2	3.06	85	68	79	270	0.80	0.93	3.17	RSIR	ST	5.9	180
Y	HFL7Y-2	2.65	85	60	70	238	0.71	0.82	2.80	RSIR	ST	6.7	230
	HFL11Y-2	4.51	105	95	110	377	0.90	1.05	3.59	RSIR	ST	6.7	230
JE	HFL15JE-2	5.12	148	135	157	536	0.91	1.06	3.62	RSIR	ST/FC	7.7	230
	HFL19JE-2	5.84	186	155	180	615	0.83	0.97	3.31	RSIR	ST/FC	8.2	230
JX	JX46LHF2	4.60	115	126	147	500	1.10	1.27	4.35	RSIR	ST/FC	8.0	230
	JX51LHF2	5.12	132	150	174	595	1.14	1.32	4.51	RSIR	ST/FC	8.3	230
	JX51LHE2	5.12	130	145	169	575	1.12	1.30	4.43	RSCR	ST/FC	8.3	230
	JX58LHE2	5.84	142	170	198	675	1.20	1.39	4.75	RSCR	ST/FC	8.3	230
	JX58LHF2	5.84	148	170	198	675	1.15	1.34	4.56	RSIR	ST/FC	8.3	230
YX	YX58LHE2	5.84	140	175	204	694	1.25	1.45	4.96	RSCR	OC/FC	9.5	290
YG	HCL25YG-2	7.68	220	215	250	853	0.98	1.14	3.88	CSIR	OC/FC	9.5	290
	HCL27YG-2	8.69	264	250	291	992	0.95	1.10	3.76	CSIR	OC/FC	9.5	290
YE	HCL21YE-2	6.73	163	180	209	714	1.10	1.28	4.38	CSIR	OC/FC	9.0	290
	HBL23YE-2	7.03	176	190	221	754	1.08	1.26	4.28	CSR	OC/FC	9.3	290
	HBL25YE-2	7.68	208	222	258	881	1.07	1.24	4.24	CSR	OC/FC	9.5	290
	HFL27YE-2	8.69	265	240	279	952	0.91	1.05	3.59	RSIR	OC/FC	9.5	290
	HBL27YE-2	8.69	232	240	279	952	1.03	1.20	4.11	CSR	OC/FC	9.5	290

Test Condition(ASHRAE) LBP

1. Evaporating temperature : -23.3 °C (-10 °F)
2. Condensing temperature : 54.4 °C (130 °F)
3. Ambient temperature : 32.2 °C (90 °F)
4. Gas superheated to : 32.2 °C (90 °F)
5. Liquid subcooled to : 32.2 °C (90 °F)

Motor Type

1. RSIR : Resistance Start Induction Run
2. RSCR : Resistance Start Capacitor Run
3. CSIR : Capacitor Start Induction Run
4. CSR : Capacitor Start Capacitor Run

Compressor Cooling

1. ST : Static Cooling
2. OC : Oil Cooling
3. FC : Fan Cooling

R134a LBP

220V 60Hz

Remark (*) means under development model

Series	Model	Displacement [cc/rev]	Consumption Power [W]	Cooling Capacity			Efficiency			Motor Type	Cooling Type	Net Weight [kg]	Oil Qty. [cc]
				kcal/h	Watt	Btu/h	EFF	COP	EER				
							kcal/Wh	W/W	Btu/Wh				
DS	DS22LHS4	2.18	55	45	52	179	0.82	0.95	3.25	RSIR	ST	6.0	180
	DS25LHS8	2.54	63	50	58	198	0.79	0.92	3.15	RSIR	ST	6.0	180
			69	60	70	238	0.87	1.01	3.45	RSIR	ST	6.0	180
	DS25LHP8-K	2.54	75	50	58	198	0.67	0.78	2.65	RSCR	ST	6.0	180
			80	60	70	238	0.75	0.87	2.98	RSCR	ST	6.0	180
	DS25LHS4	2.54	69	60	70	238	0.87	1.01	3.45	RSIR	ST	6.0	180
	DS30LHS4	3.06	85	70	81	278	0.82	0.96	3.27	RSIR	ST	6.0	180
	DS30LHP4-K	3.06	88	70	81	278	0.80	0.93	3.16	RSCR	ST	6.0	180
DS35LHP4-K	3.5	92	80	93	317	0.87	1.01	3.45	RSCR	ST	6.0	180	
WX	WX20LHS4T	2.01	66	35	41	139	0.53	0.62	2.10	RSIR	ST	5.9	180
	WX24LHP4	2.54	62	50	58	198	0.81	0.94	3.20	RSCR	ST	5.9	180
	WX24LHP4T	2.54	69	50	58	198	0.72	0.84	2.88	RSCR	ST	5.9	180
	WX24LHP4T-K	2.54	85	45	52	179	0.53	0.62	2.10	RSCR	ST	5.9	180
	WX24LHS4	2.54	69	50	58	198	0.72	0.84	2.88	RSIR	ST	5.9	180
	WX24LHS4T	2.54	69	45	52	179	0.65	0.76	2.59	RSIR	ST	5.9	180
	WX24LHS4TP	2.54	75	50	58	198	0.67	0.78	2.65	RSIR	ST	5.9	180
	WX24LHS4TB	2.54	75	50	58	198	0.67	0.78	2.65	RSIR	ST	5.9	180
	WX24LHS4TF	2.54	75	50	58	198	0.67	0.78	2.65	RSIR	ST	5.9	180
	WX24LHS4W	2.54	65	50	58	198	0.77	0.89	3.05	RSIR	ST	5.9	180
	WX24LHP4W	2.54	62	50	58	198	0.81	0.94	3.20	RSCR	ST	5.9	180
	WX24LHS4W-K	2.54	78	50	58	198	0.64	0.75	2.54	RSIR	ST	5.9	180
	WX24LHP4W-K	2.54	82	50	58	198	0.61	0.71	2.42	RSCR	ST	5.9	180
	WX24LHT4W-K	2.54	85	50	58	198	0.59	0.68	2.33	RSIR	ST	5.9	180
	WX24LHP4W-K	2.54	82	50	58	198	0.61	0.71	2.42	RSCR	ST	5.9	180
	WX30LHP4	3.06	82	70	81	278	0.85	0.99	3.39	RSCR	ST	5.9	180
	WX30LHS4	3.06	84	70	81	278	0.83	0.97	3.31	RSIR	ST	5.9	180
	WX30LHS4T	3.06	90	70	81	278	0.78	0.90	3.09	RSIR	ST	5.9	180
	WX30LHS4W-K	3.06	100	65	76	258	0.65	0.76	2.58	RSIR	ST	5.9	180
	WX30LHP4W-K	3.06	90	65	76	258	0.72	0.84	2.87	RSCR	ST	5.9	180
	WX30LHS8	3.06	86	60	70	238	0.70	0.81	2.77	RSIR	ST	5.9	180
84			70	81	278	0.83	0.97	3.31	RSIR	ST	5.9	180	
WX35LHS4W	3.51	105	80	93	317	0.76	0.89	3.02	RSIR	ST	6.3	180	
Y	HSL5Y-4	2.29	67	50	58	198	0.75	0.87	2.96	RSIR	ST	6.3	230
	HSL5Y-4P	2.29	78	50	58	198	0.64	0.75	2.54	RSIR	ST	6.3	230
	HSL7Y-4	2.65	80	60	70	238	0.75	0.87	2.98	RSIR	ST	6.7	230
	HSL7Y-4P	2.65	80	60	70	238	0.75	0.87	2.98	RSIR	ST	6.7	230
	HSL9Y-4	3.43	93	70	81	278	0.75	0.88	2.99	RSIR	ST	6.7	230
	HSL9Y-4A	3.43	85	70	81	278	0.82	0.96	3.27	RSIR	ST	6.7	230
	HPL11Y-4	4.51	105	95	110	377	0.90	1.05	3.59	RSCR	ST	6.7	230
	HSL11Y-4	4.51	123	95	110	377	0.77	0.90	3.06	RSIR	ST	6.7	230
	HSL11Y-4A	4.51	108	95	110	377	0.88	1.02	3.49	RSIR	ST	6.7	230

R134a LBP

220V 60Hz

Remark (*) means under development model

Series	Model	Displacement [cc/rev]	Consumption Power [W]	Cooling Capacity			Efficiency			Motor Type	Cooling Type	Net Weight [kg]	Oil Qty. [cc]
				kcal/h	Watt	Btu/h	EFF	COP	EER				
							kcal/Wh	W/W	Btu/Wh				
JE	HSL13JE-4	4.62	124	120	140	476	0.97	1.13	3.84	RSIR	ST/FC	7.7	230
	HDL15JE-4	5.1	122	135	157	536	1.11	1.29	4.39	CSR	ST/FC	7.2	230
	HKL15JE-4	5.12	137	135	157	536	0.99	1.15	3.91	CSIR	ST/FC	7.2	230
	HPL15JE-4	5.12	130	135	157	536	1.04	1.21	4.12	RSCR	ST/FC	7.7	230
	HSL15JE-4	5.12	137	135	157	536	0.99	1.15	3.91	RSIR	ST/FC	7.7	230
	HSL15JE-4C	5.12	137	135	157	536	0.99	1.15	3.91	RSIR	ST/FC	7.7	230
	HPL17JE-4	5.55	136	145	169	575	1.07	1.24	4.23	RSCR	ST/FC	7.7	230
	HPL17JE-4A	5.55	128	145	169	575	1.13	1.32	4.50	RSCR	ST/FC	8.0	230
	HPL19JE-4	5.84	146	155	180	615	1.06	1.23	4.21	RSCR	ST/FC	8.2	230
	HSL19JE-4	5.84	151	155	180	615	1.03	1.19	4.07	RSIR	ST/FC	8.2	230
JX	JX41LHP4	4.09	105	105	122	417	1.00	1.16	3.97	RSCR	ST/FC	7.6	230
	JX41LHP4-K	4.09	104	103	120	409	0.99	1.15	3.93	RSCR	ST/FC	7.9	230
	JX41LHS4	4.09	112	104	121	413	0.93	1.08	3.68	RSIR	ST/FC	7.6	230
	JX46LHP4	4.62	110	128	149	508	1.16	1.35	4.62	RSCR	ST/FC	8.0	230
	JX46LHP4-K	4.62	117	127	148	504	1.09	1.26	4.31	RSCR	ST/FC	8.0	230
	JX46LHS4	4.62	124	131	152	520	1.06	1.23	4.19	RSIR	ST/FC	8.0	230
	JX46LHT4	4.62	112	120	140	476	1.07	1.25	4.25	RSIR	ST/FC	8.0	230
	JX51LHP4	5.12	124	150	174	595	1.21	1.41	4.80	RSCR	ST/FC	8.2	230
	JX51LHS4	5.12	136	150	174	595	1.10	1.28	4.38	RSIR	ST/FC	8.2	230
	JX55LHP4	5.5	143	157	183	623	1.10	1.28	4.36	RSCR	ST/FC	8.2	230
	JX58LHK4	5.84	161	170	198	675	1.06	1.23	4.19	CSIR	ST/FC	8.2	230
	JX58LHP4	5.84	139	170	198	675	1.22	1.42	4.85	RSCR	ST/FC	8.2	230
	JX58LHP4-K	5.85	155	170	198	675	1.10	1.28	4.35	RSCR	ST/FC	8.2	230
JX58LHS4	5.84	150	170	198	675	1.13	1.32	4.50	RSIR	ST/FC	8.2	230	
YH	HPL15YH-4	5.12	122	135	157	536	1.11	1.29	4.39	RSCR	ST/OC/FC	8.9	290
	HPL17YH-4	5.55	131	148	172	587	1.13	1.31	4.48	RSCR	ST/OC/FC	8.9	290
	HPL19YH-4	5.84	137	170	198	675	1.24	1.44	4.92	RSCR	ST/OC/FC	9.5	290
	HDL21YH-4	6.72	156	189	220	750	1.21	1.41	4.81	CSR	ST/OC/FC	9.5	290
	HPL21YH-4	6.73	155	188	219	746	1.21	1.41	4.81	RSCR	ST/OC/FC	9.5	290
	HPL23YH-4	7.03	165	201	234	798	1.22	1.42	4.83	RSCR	ST/OC/FC	9.5	290
	HPL26YH-4	8.25	205	235	273	933	1.15	1.33	4.55	RSCR	ST/OC/FC	9.5	290
YX	YX46LHP4	4.62	104	125	145	496	1.20	1.40	4.77	RSCR	ST/OC/FC	8.8	290
	YX51LHP4	5.12	120	150	174	595	1.25	1.45	4.96	RSCR	ST/OC/FC	8.8	290
	YX51LHP4-K	5.12	128	144	168	572	1.12	1.31	4.46	RSCR	ST/OC/FC	8.8	290
	YX58LHP4	5.84	133	172	200	683	1.29	1.50	5.13	RSCR	ST/OC/FC	9.8	290
YG	HPL21YG-4	6.73	175	185	215	734	1.06	1.23	4.20	RSCR	ST/OC/FC	9.0	290
	HPL27YG-4A	8.69	232	250	291	992	1.08	1.25	4.28	RSCR	ST/OC/FC	9.5	290
	HPL30YG-4	9.92	247	283	329	1123	1.15	1.33	4.55	RSCR	ST/OC/FC	9.5	290

R134a LBP

220V 60Hz

Remark (*) means under development model

Series	Model	Displacement [cc/rev]	Consumption Power [W]	Cooling Capacity			Efficiency			Motor Type	Cooling Type	Net Weight [kg]	Oil Qty. [cc]
				kcal/h	Watt	Btu/h	EFF	COP	EER				
							kcal/Wh	W/W	Btu/Wh				
YE	HSL21YE-4	6.73	180	180	209	714	1.00	1.16	3.97	RSIR	ST/OC/FC	9.0	290
	HPL21YE-4	6.73	165	180	209	714	1.09	1.27	4.33	RSCR	ST/OC/FC	9.0	290
	HKL23YE-4	7.03	190	190	221	754	1.00	1.16	3.97	CSIR	ST/OC/FC	9.3	290
	HPL23YE-4	7.03	177	190	221	754	1.07	1.25	4.26	RSCR	ST/OC/FC	9.3	290
	HKL25YE-4	7.68	204	210	244	833	1.03	1.20	4.09	CSIR	ST/OC/FC	9.5	290
	HPL25YE-4	7.68	192	210	244	833	1.09	1.27	4.34	RSCR	ST/OC/FC	9.5	290
	HSL25YE-4	7.68	207	217	252	861	1.05	1.22	4.16	RSIR	ST/OC/FC	9.5	290
	HKL27YE-4	8.69	218	240	279	952	1.10	1.28	4.37	CSIR	ST/OC/FC	9.5	290
	HDL27YE-4-K	8.69	235	240	279	952	1.02	1.19	4.05	CSR	ST/OC/FC	9.5	290
	HKL27YE-4-K	8.69	259	240	279	952	0.93	1.08	3.68	CSIR	ST/OC/FC	9.5	290
	HKL27YE-4-KD	8.69	259	240	279	952	0.93	1.08	3.68	CSIR	ST/OC/FC	9.5	290
	HPL27YE-4	8.69	230	240	279	952	1.04	1.21	4.14	RSCR	ST/OC/FC	9.5	290
	HKL30YE-4	9.92	269	273	317	1083	1.01	1.18	4.03	CSIR	ST/OC/FC	9.5	290
DH	DH70LHP4	7.03	155	207	241	821	1.34	1.55	5.30	RSCR	FC	10.4	290
	DH80LHP4	7.89	174	230	267	913	1.32	1.54	5.25	RSCR	FC	10.4	290
	DH90LHP4	8.93	202	273	317	1083	1.35	1.57	5.36	RSCR	FC	10.4	290
	DH99LHP4	9.92	229	283	329	1123	1.24	1.44	4.90	RSCR	FC	10.4	290
	DH120LHK4	12.0	314	343	399	1361	1.09	1.27	4.33	CSIR	FC	10.4	290
	DH120LHD4-K	12.0	303	340	395	1349	1.12	1.31	4.45	CSR	FC	10.1	290
	DH120LHG4	12.0	324	340	395	1349	1.05	1.22	4.16	CSIR	FC	10.4	290
	DH126LHG4	12.6	329	348	405	1381	1.06	1.23	4.20	CSIR	FC	10.4	290
DM	DM99LHK4	9.92	253	286	333	1135	1.13	1.31	4.49	CSIR	FC	9.7	290
	DM99LHD4	9.92	239	294	342	1167	1.23	1.43	4.88	CSR	FC	9.7	290
	DM99LHP4	9.92	238	290	337	1151	1.22	1.42	4.84	RSCR	FC	9.7	290

Test Condition(ASHRAE) LBP

1. Evaporating temperature : -23.3 °C (-10 °F)
2. Condensing temperature : 54.4 °C (130 °F)
3. Ambient temperature : 32.2 °C (90 °F)
4. Gas superheated to : 32.2 °C (90 °F)
5. Liquid subcooled to : 32.2 °C (90 °F)

Motor Type

1. RSIR : Resistance Start Induction Run
2. RSCR : Resistance Start Capacitor Run
3. CSIR : Capacitor Start Induction Run
4. CSR : Capacitor Start Capacitor Run

Compressor Cooling

1. ST : Static Cooling
2. OC : Oil Cooling
3. FC : Fan Cooling

R134a LBP

220-240V 50Hz

Remark (*) means under development model

Series	Model	Displacement [cc/rev]	Consumption Power [W]	Cooling Capacity			Efficiency			Motor Type	Cooling Type	Net Weight [kg]	Oil Qty. [cc]	
				kcal/h	Watt	Btu/h	EFF	COP	EER					
							kcal/Wh	W/W	Btu/Wh					
DS	DS25LHS8	2.54	63	50	58	198	0.79	0.92	3.15	RSIR	ST	6.0	180	
			69	60	70	238	0.87	1.01	3.45					
	DS25LHP8-K	2.54	63	41	48	163	0.65	0.76	2.58	RSCR	ST	6.0	180	
			68	53	62	210	0.78	0.91	3.09					
	DS30LHP5-K	3.06	78	60	70	238	0.77	0.89	3.05	RSCR	ST	6.0	180	
WX	WX20LHS5T	2.01	58	29	34	115	0.50	0.58	1.98	RSIR	ST	5.9	180	
	WX24LHS5W-K	2.54	66	41	48	163	0.62	0.72	2.47	RSIR	ST	6.1	180	
	WX24LHS5	2.54	66	40	47	159	0.61	0.70	2.41	RSIR	ST	5.9	180	
	WX24LHS5T	2.54	64	40	47	159	0.63	0.73	2.48	RSIR	ST	5.9	180	
	WX24LHS5T-K	2.54	75	40	47	159	0.53	0.62	2.12	RSIR	ST	5.9	180	
	WX24LHS8	2.54	66	40	47	159	0.61	0.70	2.41	RSIR	ST	5.9	180	
			63	50	58	198	0.79	0.92	3.15					
	WX30LHS8	3.06	86	60	70	238	0.70	0.81	2.77	RSIR	ST	5.9	180	
				84	70	81	278	0.83	0.97	3.31				
	WX30LHS5	3.06	86	60	70	238	0.70	0.81	2.77	RSIR	ST	5.9	180	
	WX30LHS5T	3.06	88	59	69	234	0.67	0.78	2.66	RSIR	ST	5.9	180	
	WX30LHS5W-K	3.06	88	55	64	218	0.63	0.73	2.48	RSIR	ST	6.1	180	
	WX30LHT5W	3.06	75	52	60	206	0.69	0.81	2.75	RSIR	ST	5.9	180	
	WX30LHT5W-K	3.06	101	53	62	210	0.52	0.61	2.08	RSIR	ST	6.1	180	
	WX35LHS5W-K	3.50	98	65	76	258	0.66	0.77	2.63	RSIR	ST	5.9	180	
	WX35LHT5W	3.50	99	64	74	254	0.65	0.75	2.57	RSIR	ST	5.9	180	
Y	HSL5Y-5P	2.29	64	35	41	139	0.55	0.64	2.17	RSIR	ST	6.7	230	
	HPL7Y-5	2.65	62	50	58	198	0.81	0.94	3.20	RSCR	ST	6.7	230	
	HSL7Y-5	2.65	74	48	56	190	0.65	0.75	2.57	RSIR	ST	6.7	230	
	HSL9Y-5	3.43	81	58	67	230	0.72	0.83	2.84	RSIR	ST	6.7	230	
	HSL11Y-5	4.51	109	80	93	317	0.73	0.85	2.91	RSIR	ST	6.7	230	
	HSL11Y-5-K	4.51	121	84	98	333	0.69	0.81	2.75	RSIR	ST	7.0	230	
	HSL11Y-5-L	4.51	149	80	93	317	0.54	0.62	2.13	RSIR	ST	6.6	230	
	HPL11Y-5-K	4.51	109	80	93	317	0.73	0.85	2.91	RSCR	ST	6.6	230	
JE	HPL13JE-5	4.62	97	93	108	369	0.96	1.12	3.80	RSCR	ST/FC	7.4	230	
	HPL15JE-5	5.12	107	107	124	425	1.00	1.16	3.97	RSCR	ST/FC	7.7	230	
	HSL15JE-5	5.12	114	108	126	429	0.95	1.10	3.76	RSIR	ST/FC	7.7	230	
	HSL15JE-5C	5.12	115	108	126	429	0.94	1.09	3.73	RSIR	ST/FC	7.8	230	
	HSL17JE-5	5.55	129	126	147	500	0.98	1.14	3.88	RSIR	ST/FC	7.7	230	
	HPL19JE-5	5.84	124	134	156	532	1.08	1.26	4.29	RSCR	ST/FC	8.2	230	
	HSL19JE-5	5.84	133	130	151	516	0.98	1.14	3.88	RSIR	ST/FC	8.2	230	
	HSL19JE-5A	5.84	141	135	157	536	0.96	1.11	3.80	RSIR	ST/FC	7.8	230	
JX	JX41LHP5-K	4.09	95	88	102	349	0.93	1.08	3.68	RSCR	ST/FC	7.9	230	
	JX41LHS5	4.09	101	89	104	353	0.88	1.02	3.50	RSIR	ST/FC	7.6	230	
	JX46LHS5	4.6	90	100	116	397	1.11	1.29	4.41	RSIR	ST/FC	8.0	230	
	JX51LHS5-K	5.12	134	114	133	452	0.85	0.99	3.38	RSIR	ST/FC	8.0	230	
	JX51LHS5	5.12	137	121	141	480	0.88	1.03	3.50	RSIR	ST/FC	8.2	230	
	JX51LHT5	5.12	121	115	134	456	0.95	1.11	3.77	RSIR	ST/FC	8.2	230	
	JX55LHP5-K	5.55	131	128	149	508	0.98	1.14	3.88	RSCR	ST/FC	7.7	230	
	JX55LHS5-K	5.55	137	125	146	497	0.91	1.06	3.63	RSIR	ST/FC	7.7	230	
	JX58LHK5	5.84	139	141	164	560	1.01	1.18	4.03	CSIR	ST/FC	8.2	230	
	JX58LHP5	5.84	120	140	163	556	1.17	1.36	4.63	RSCR	ST/FC	8.2	230	
	JX58LHP5-K	5.84	134	140	163	556	1.04	1.22	4.15	RSCR	ST/FC	7.4	230	
	JX58LHS5	5.84	139	141	164	560	1.01	1.18	4.03	RSIR	ST/FC	8.2	230	
	JX58LHS5-K	5.84	145	140	163	556	0.97	1.12	3.83	RSIR	ST/FC	7.4	230	
	JX58LHS5A	5.84	150	140	163	556	0.93	1.09	3.70	RSIR	ST/FC	7.4	230	

Remark (*) means under development model

Series	Model	Displacement [cc/rev]	Consumption Power [W]	Cooling Capacity			Efficiency			Motor Type	Cooling Type	Net Weight [kg]	Oil Qty. [cc]
				kcal/h	Watt	Btu/h	EFF	COP	EER				
							kcal/Wh	W/W	Btu/Wh				
YH	HPL17YH-5	5.55	108	129	150	512	1.19	1.39	4.74	RSCR	ST/OC/FC	9.5	290
	HPL19YH-5	5.84	115	136	158	540	1.18	1.38	4.69	RSCR	ST/OC/FC	9.5	290
	HPL21YH-5	6.73	129	152	177	603	1.18	1.37	4.68	RSCR	ST/OC/FC	9.5	290
	HPL23YH-5	7.03	139	166	193	659	1.19	1.39	4.74	RSCR	ST/OC/FC	9.5	290
	HPL25YH-5	7.96	155	194	226	770	1.25	1.46	4.97	RSCR	ST/OC/FC	9.5	290
	HPL25YH-5-K	7.96	161	188	219	746	1.17	1.36	4.63	RSCR	ST/OC/FC	9.5	290
	HPL26YH-5	8.25	157	192	223	762	1.22	1.42	4.85	RSCR	ST/OC/FC	9.5	290
	HPL26YH-5-K	8.25	174	200	233	794	1.15	1.34	4.56	RSCR	ST/OC/FC	9.5	290
	HPL30YH-5	9.92	199	229	266	909	1.15	1.34	4.57	RSCR	ST/OC/FC	9.5	290
YX	YX51LHS5	5.1	99	122	142	484	1.23	1.43	4.89	RSIR	ST/OC/FC	9.0	290
	YX58LHP5	5.84	112	141	164	560	1.26	1.46	5.00	RSCR	ST/OC/FC	9.8	290
YG	HPL25YG1-5	7.68	153	180	209	714	1.18	1.37	4.67	RSCR	ST/OC/FC	9.5	290
	HPL25YG2-5	7.68	153	180	209	714	1.18	1.37	4.67	RSCR	ST/OC/FC	9.5	290
	HPL27YG1-5	8.69	175	206	240	817	1.18	1.37	4.67	RSCR	ST/OC/FC	9.5	290
	HPL30YG-5	9.92	207	235	273	933	1.14	1.32	4.51	RSCR	ST/OC/FC	9.5	290
	HPL30YG-5A	9.92	208	228	265	905	1.10	1.27	4.35	RSCR	ST/OC/FC	9.5	290
YE	HPL21YE-5-K	6.73	155	148	172	587	0.95	1.11	3.79	RSCR	ST/OC/FC	9.0	290
	HPL21YE-5-L	6.73	150	152	177	603	1.01	1.18	4.02	RSCR	ST/OC/FC	8.9	290
	HSL21YE-5	6.73	149	151	176	599	1.01	1.18	4.02	RSIR	ST/OC/FC	9.0	290
	HPL23YE-5	7.03	146	166	193	659	1.14	1.32	4.51	RSCR	ST/OC/FC	9.5	290
	HPL23YE-5-K	7.03	157	162	188	643	1.03	1.20	4.09	RSCR	ST/OC/FC	9.0	290
	HSL23YE-5	7.03	161	155	180	615	0.96	1.12	3.82	RSIR	ST/OC/FC	9.3	290
	HKL25YE-5	7.68	186	177	206	702	0.95	1.11	3.78	CSIR	ST/OC/FC	9.5	290
	HPL25YE-5-K	7.68	171	175	203	694	1.02	1.19	4.05	RSCR	ST/OC/FC	9.0	290
	HPL25YE-5-L	7.68	169	180	209	714	1.07	1.24	4.23	RSCR	ST/OC/FC	9.0	290
	HSL25YE-5	7.68	176	174	202	690	0.99	1.15	3.92	RSIR	ST/OC/FC	9.5	290
	HKL27YE-5	8.69	200	200	233	794	1.00	1.16	3.97	CSIR	ST/OC/FC	9.3	290
	HPL27YE-5	8.69	180	204	237	810	1.13	1.32	4.50	RSCR	ST/OC/FC	9.5	290
	HPL27YE-5-K	8.69	196	199	231	790	1.02	1.18	4.03	RSCR	ST/OC/FC	9.0	290
	HSL27YE-5	8.69	196	197	229	782	1.01	1.17	3.99	RSIR	ST/OC/FC	9.5	290
	HSL27YE-5A	8.69	193	195	227	774	1.01	1.18	4.01	RSIR	ST/OC/FC	9.5	290
	HKL30YE-5	9.92	241	236	274	937	0.98	1.14	3.89	CSIR	ST/OC/FC	9.5	290
	HPL30YE-5	9.92	211	228	265	905	1.08	1.26	4.29	RSCR	ST/OC/FC	9.5	290
	HPL30YE-5-K	9.92	207	221	257	876	1.06	1.24	4.22	RSCR	ST/OC/FC	9.0	290
	HSL30YE-5	9.92	253	230	267	913	0.91	1.06	3.61	RSIR	ST/OC/FC	9.5	290
DH	DH70LHP5	7.03	124	161	187	639	1.30	1.51	5.15	RSCR	FC	10.4	290
	DH80LHP5	7.89	143	189	220	750	1.32	1.54	5.24	RSCR	FC	10.4	290
	DH90LHK5	8.93	175	205	238	814	1.17	1.36	4.65	CSIR	FC	10.4	290
	DH90LHP5	8.93	157	205	238	814	1.31	1.52	5.18	RSCR	FC	10.4	290
	DH120LHG5	12.0	266	270	314	1071	1.02	1.18	4.03	CSIR	FC	10.4	290
	DH126LHG5	12.6	275	290	337	1151	1.05	1.23	4.18	CSIR	FC	10.4	290
DM	DM80LHP5	7.89	152	184	214	730	1.21	1.41	4.80	RSCR	FC	9.7	290

Test Condition(ASHRAE) LBP

1. Evaporating temperature : -23.3 °C (-10 °F)
2. Condensing temperature : 54.4 °C (130 °F)
3. Ambient temperature : 32.2 °C (90 °F)
4. Gas superheated to : 32.2 °C (90 °F)
5. Liquid subcooled to : 32.2 °C (90 °F)

Motor Type

1. RSIR : Resistance Start Induction Run
2. RSCR : Resistance Start Capacitor Run
3. CSIR : Capacitor Start Induction Run
4. CSR : Capacitor Start Capacitor Run

Compressor Cooling

1. ST : Static Cooling
2. OC : Oil Cooling
3. FC : Fan Cooling

R600a LBP

110V 60Hz

Remark (*) means under development model

Series	Model	Displacement [cc/rev]	Consumption Power [W]	Cooling Capacity			Efficiency			Motor Type	Cooling Type	Net Weight [kg]	Oil Qty. [cc]
				kcal/h	Watt	Btu/h	EFF kcal/Wh	COP W/W	EER Btu/Wh				
WX	* WX35LIE3-K	3.50	60	51	59	202	0.85	0.99	3.37	RSCR	ST	5.9	180

R600a LBP

220V 60Hz

Remark (*) means under development model

Series	Model	Displacement [cc/rev]	Consumption Power [W]	Cooling Capacity			Efficiency			Motor Type	Cooling Type	Net Weight [kg]	Oil Qty. [cc]
				kcal/h	Watt	Btu/h	EFF kcal/Wh	COP W/W	EER Btu/Wh				
WX	WX35LIP4	3.50	57	51	59	202	0.89	1.04	3.55	RSCR	ST	5.9	180
	WX35LIS4	3.50	61	51	59	202	0.84	0.97	3.32	RSIR	ST	5.9	180
JX	JX51LIS4	5.12	75	80	93	317	1.07	1.24	4.23	RSIR	ST/FC	8.2	180
	JX58LIS4	5.84	86	92	107	365	1.07	1.24	4.25	RSIR	ST/FC	8.2	180

R600a LBP

220-240V 50Hz

Remark (*) means under development model

Series	Model	Displacement [cc/rev]	Consumption Power [W]	Cooling Capacity			Efficiency			Motor Type	Cooling Type	Net Weight [kg]	Oil Qty. [cc]
				kcal/h	Watt	Btu/h	EFF kcal/Wh	COP W/W	EER Btu/Wh				
JX	JX46LIP5	4.62	57	59	69	234	1.04	1.20	4.11	RSCR	FC	8.6	230
DH	DH80LIP5	7.89	83	104	121	413	1.26	1.47	5.01	RSCR	FC	10.4	290
	DH90LIP5	8.96	97	122	141	482	1.26	1.46	5.00	RSCR	FC	10.4	290
	DH99LIP5	9.92	106	141	164	558	1.33	1.55	5.28	RSCR	FC	10.4	290
	DH108LIP5	10.80	118	146	170	579	1.23	1.44	4.90	RSCR	FC	10.4	290
	DH114LIP5	11.40	125	152	176	602	1.21	1.41	4.81	RSCR	FC	10.4	290
	DH120LIP5	11.90	134	166	193	659	1.24	1.45	4.93	RSCR	FC	10.4	290
	DH126LIP5	12.60	147	181	211	718	1.23	1.43	4.89	RSCR	FC	10.4	290
	DH132LIP5	13.20	142	183	213	726	1.29	1.50	5.11	RSCR	FC	10.4	290
	DH144LIP5	14.40	170	205	239	814	1.21	1.41	4.80	RSCR	FC	10.4	290
	DH152LIP5	15.20	168	218	254	865	1.30	1.51	5.15	RSCR	FC	10.4	290

Test Condition(ASHRAE) LBP

1. Evaporating temperature : -23.3 °C (-10 °F)
2. Condensing temperature : 54.4 °C (130 °F)
3. Ambient temperature : 32.2 °C (90 °F)
4. Gas superheated to : 32.2 °C (90 °F)
5. Liquid subcooled to : 32.2 °C (90 °F)

Motor Type

1. RSIR : Resistance Start Induction Run
2. RSCR : Resistance Start Capacitor Run
3. CSIR : Capacitor Start Induction Run
4. CSR : Capacitor Start Capacitor Run

Compressor Cooling

1. ST : Static Cooling
2. OC : Oil Cooling
3. FC : Fan Cooling

Appearance

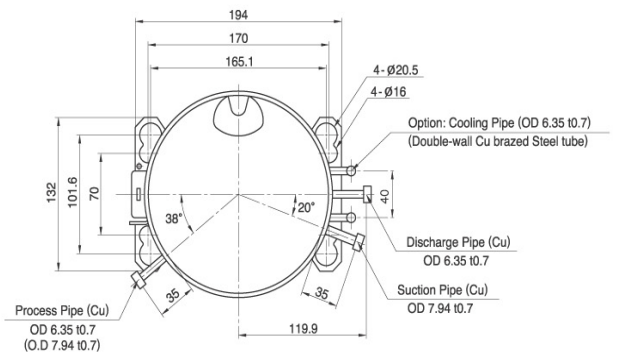
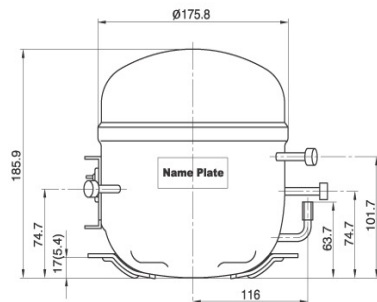
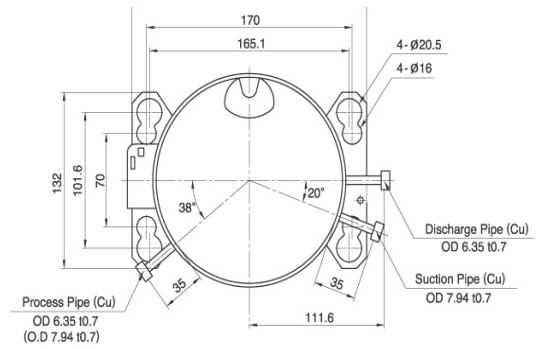
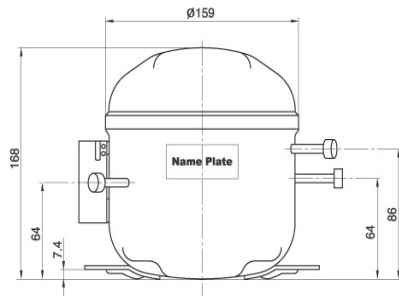
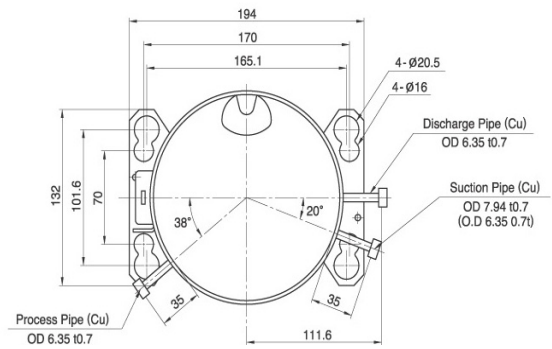
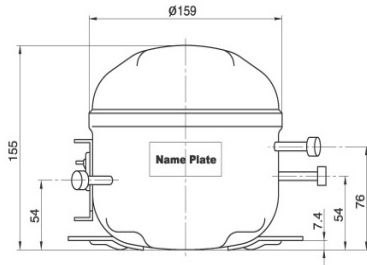
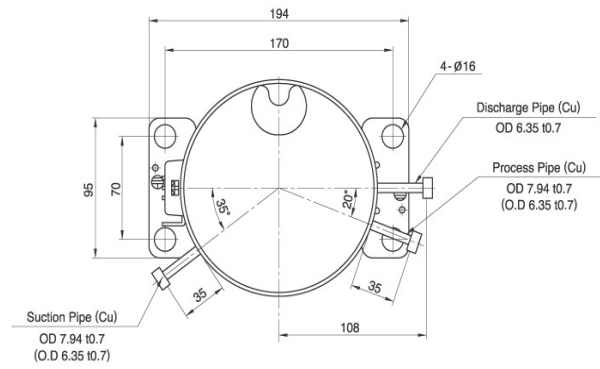
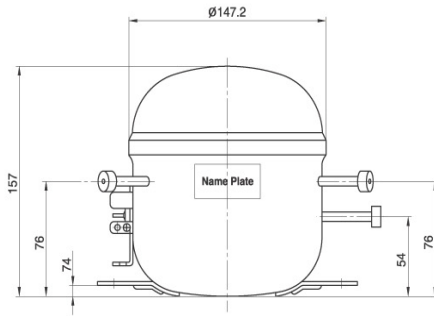

Appearance

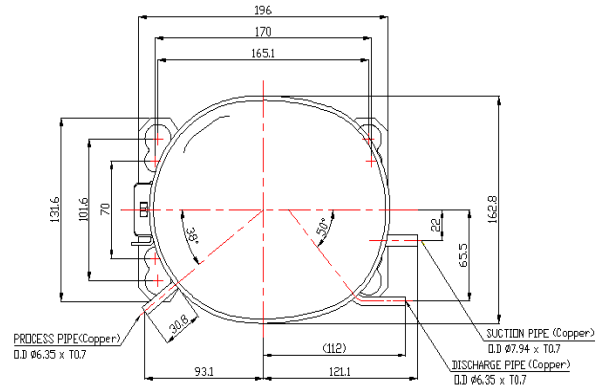
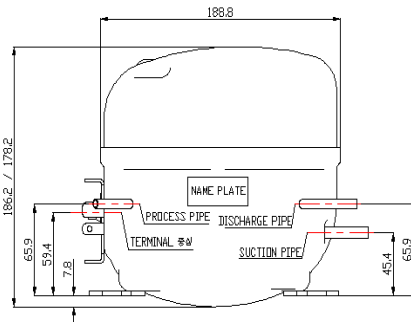
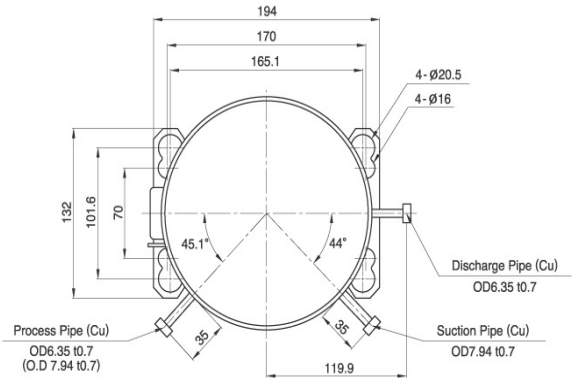
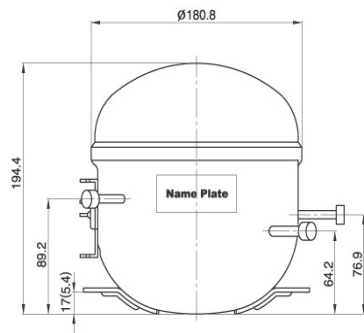
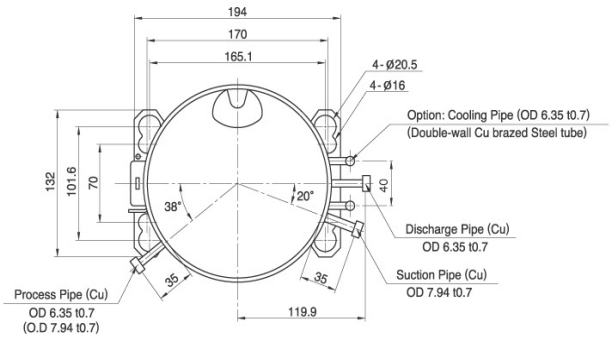
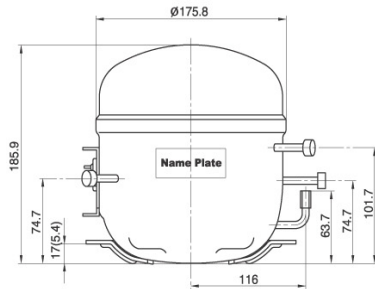

Pipe(Tube) Size

PIPE	O.D	t(mm)	I.D	material	Remark	
Suction Pipe	Φ 7.94	0.7	Φ 6.54	copper	DAEWOO Standard	
		0.9	Φ 6.14	copper		
Discharge Pipe	Φ 6.35	0.7	Φ 4.95	copper	DAEWOO Standard	
		0.9	Φ 4.55	copper		
Process Pipe	Φ 6.35	0.7	Φ 4.95	copper	DAEWOO Standard	
		Φ 7.94	0.7	Φ 6.54	copper	WX-Series Standard
			0.9	Φ 6.14	copper	
Cooling Pipe	Φ 6.35	0.7	Φ 4.95	copper		

Assembly Diagram

1. PTC Relay Type

Wiring Diagram

1-1. Relay_Cover , Can Type (Single)_Capacitor

Motor Type	RSIR	RSCR	CSIR	CSR
Running Capacitor	X	○	X	○
Starting Capacitor	X	X	○	○

1) General Type

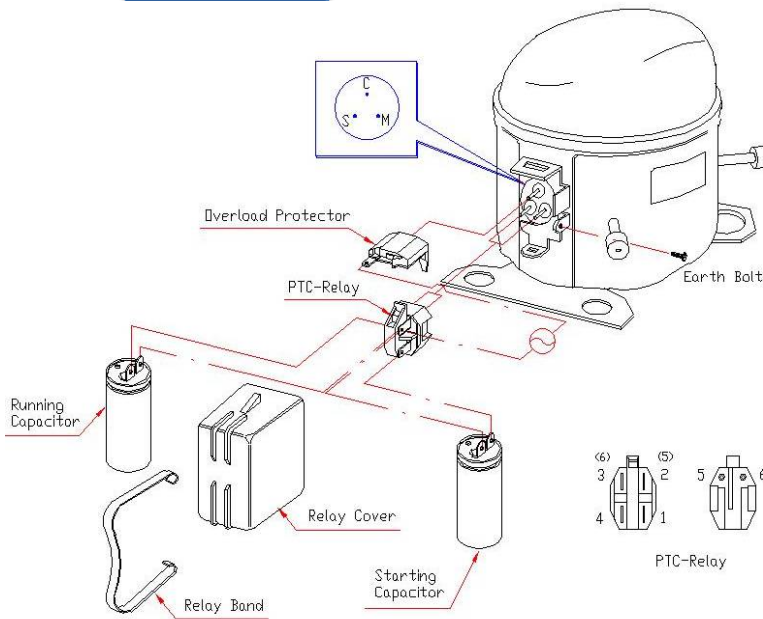

RSIR / RSCR

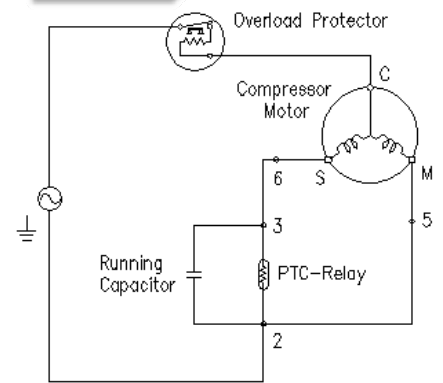

2) Cable clamp Type

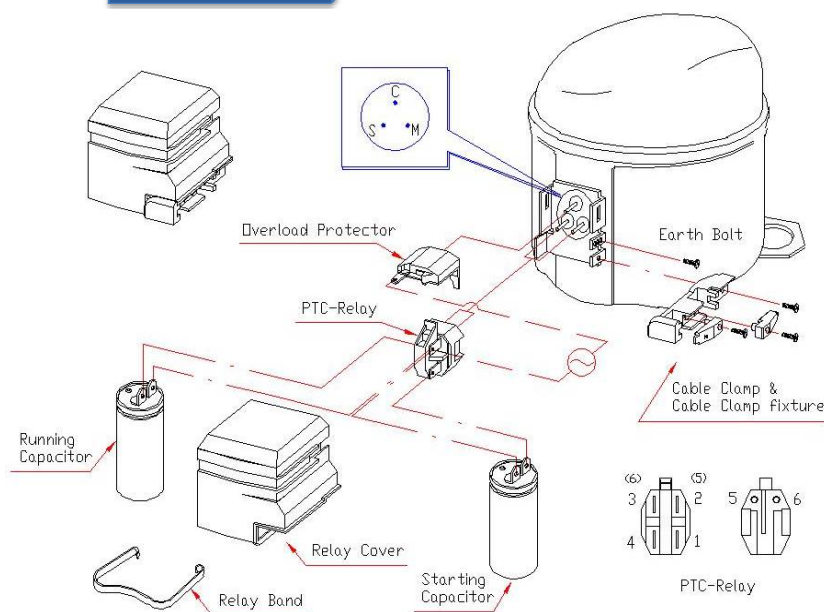

CSIR / CSR

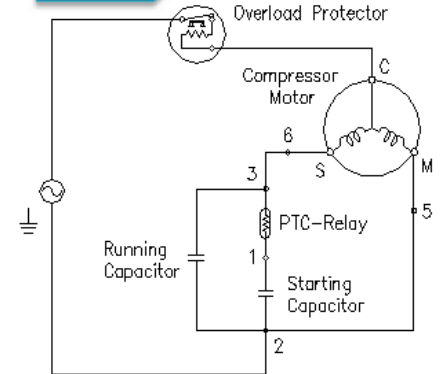

1-2. Relay_Cover , Can Type (Dual)_Capacitor

Wiring Diagram

Motor Type	RSIR	RSCR	CSIR	CSR
Running Capacitor	X	○	X	○
Starting Capacitor	X	X	○	○

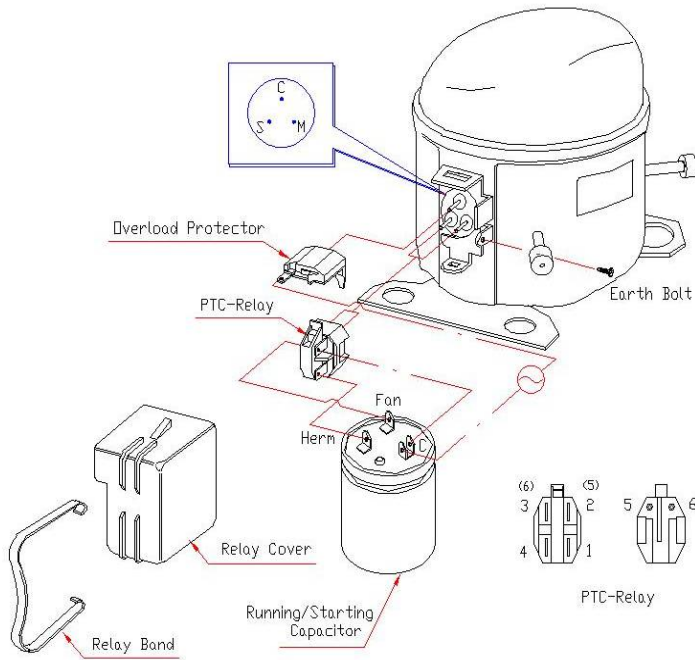

CSR

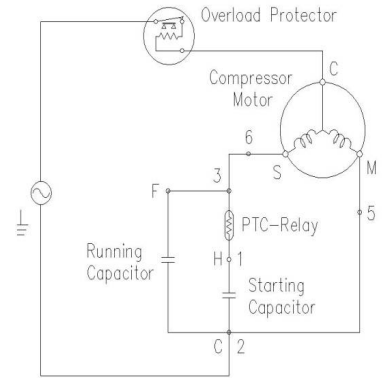

1-3. Relay_Cover , Rectangular Type_Capacitor

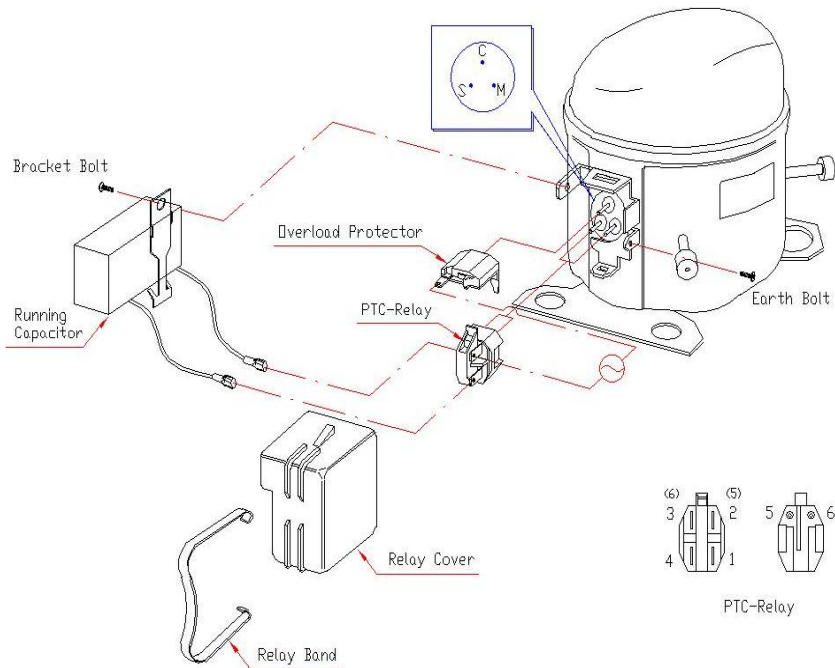

RSCR

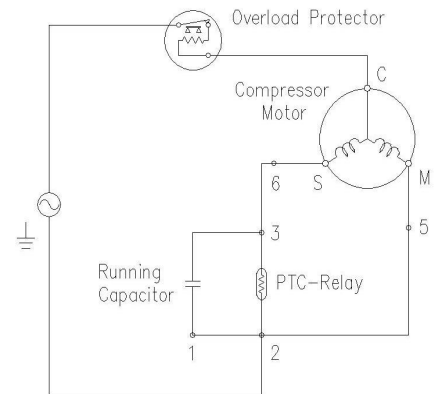

1-4. Terminal_Board

Wiring Diagram

Motor Type	RSIR	RSCR	CSIR	CSR
Running Capacitor	X	○	X	○
Starting Capacitor	X	X	○	○

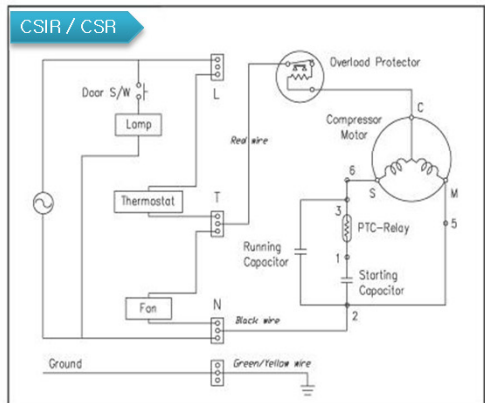
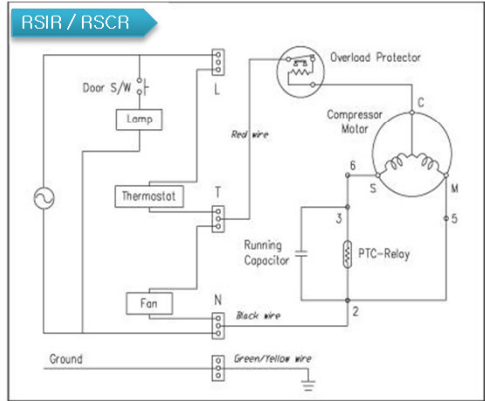
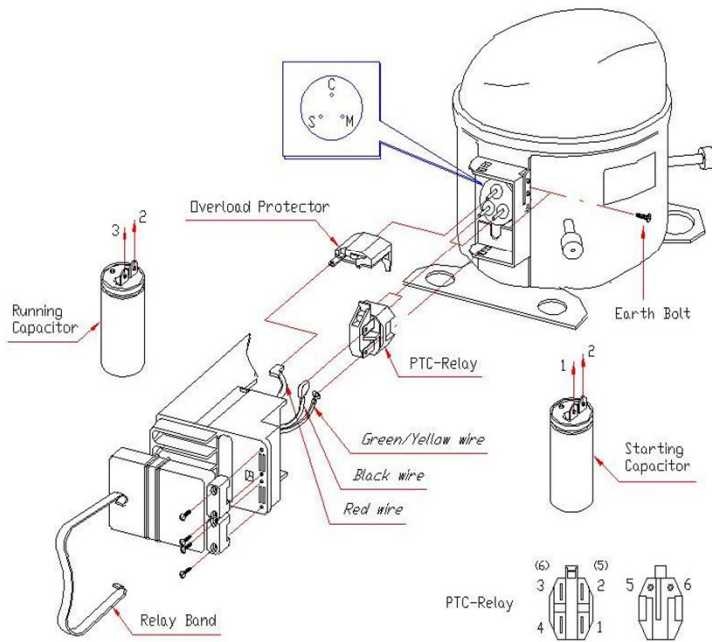

2. Current Relay Type

Wiring Diagram

2-1. General Type

Motor Type	RSIR	CSIR
Running Capacitor	X	X
Starting Capacitor	X	O

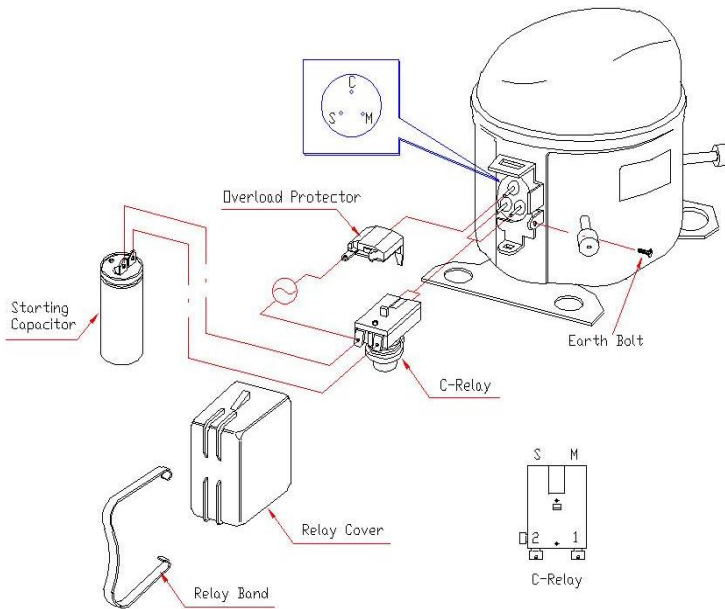

RSIR / CSIR

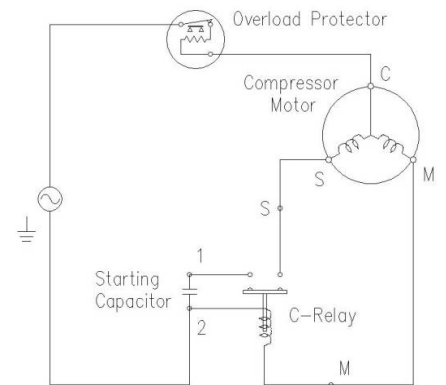

2-2. Capacitor_Bracket Type

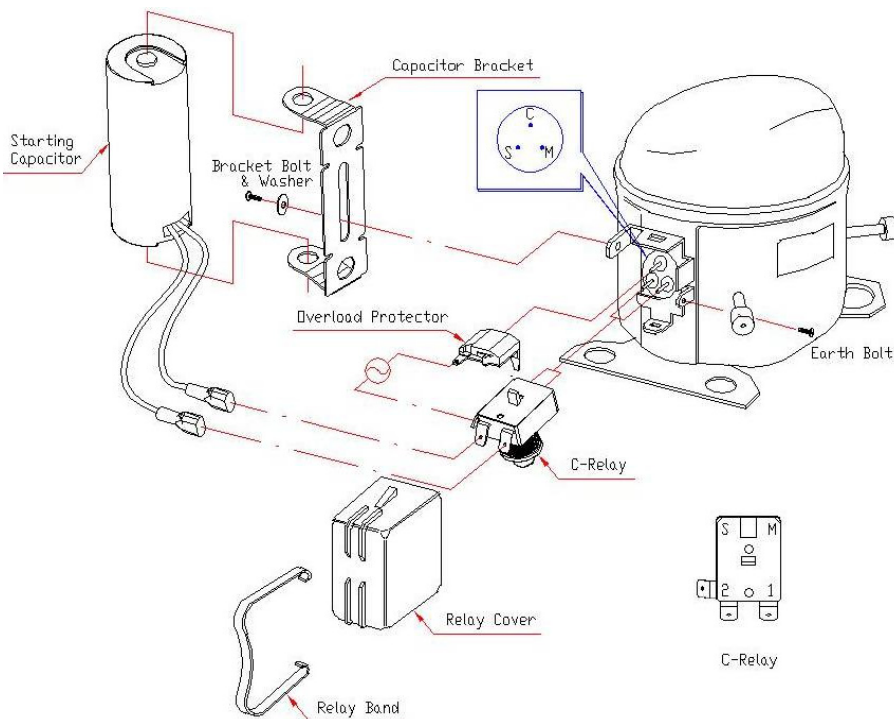

CSIR

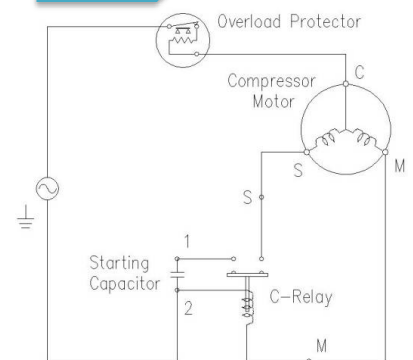

2-3. Sensata Current Relay

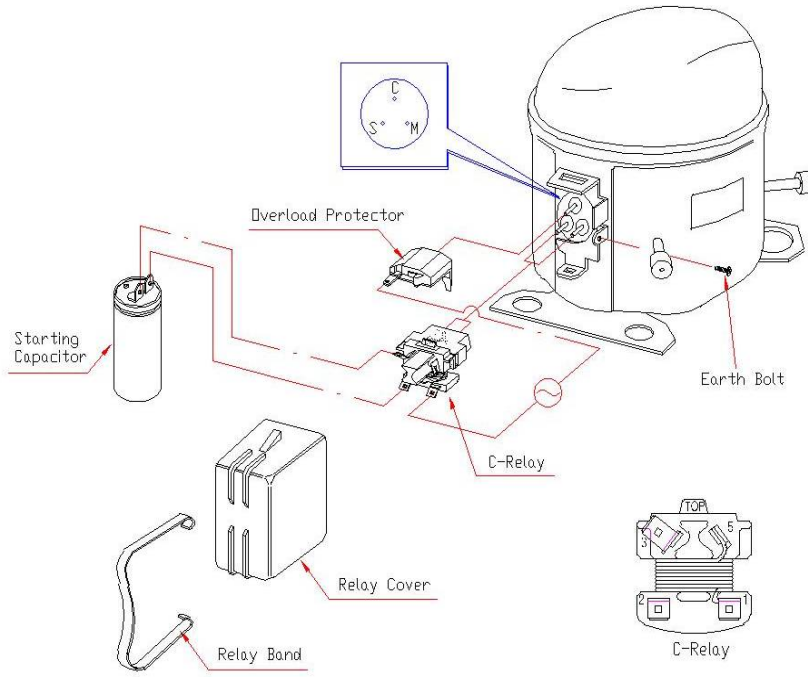

Wiring Diagram

Motor Type	RSIR	CSIR
Running Capacitor	X	X
Starting Capacitor	X	O

RSIR / CSIR

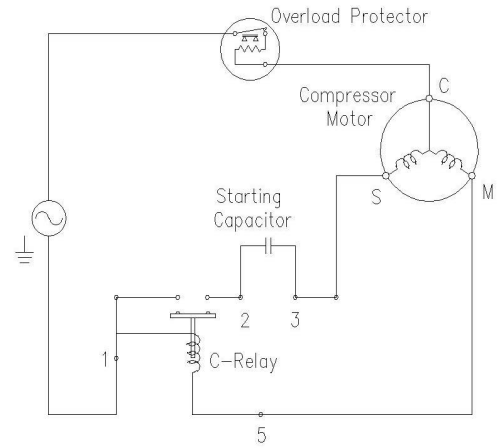

3. Combo Relay Type

Wiring Diagram

3-1. 11SP

Motor Type	RSIR	RSCR	CSIR	CSR
Running Capacitor	X	○	X	○
Starting Capacitor	X	X	○	○

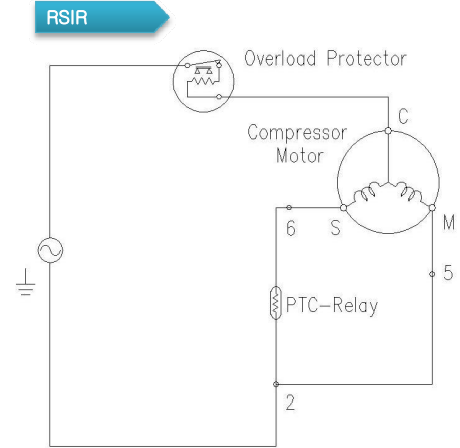
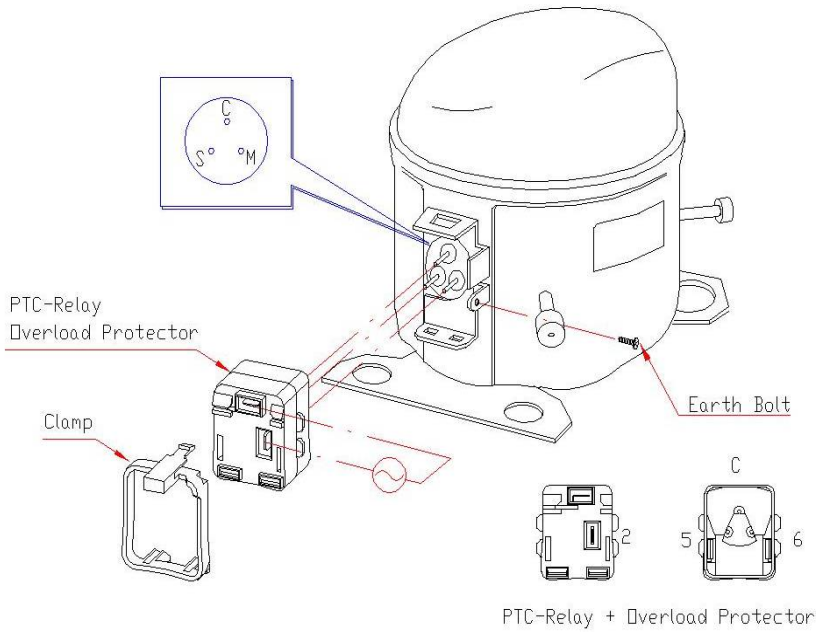

3-2. 12SP

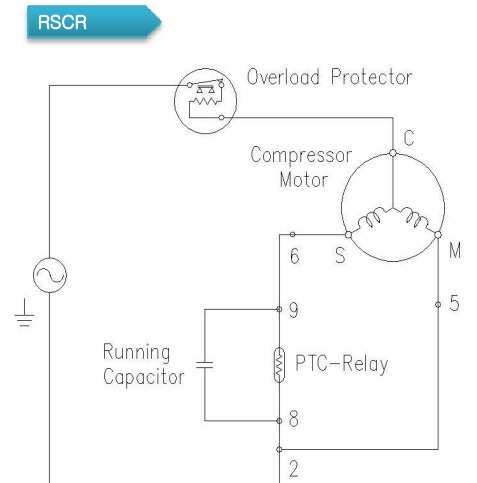
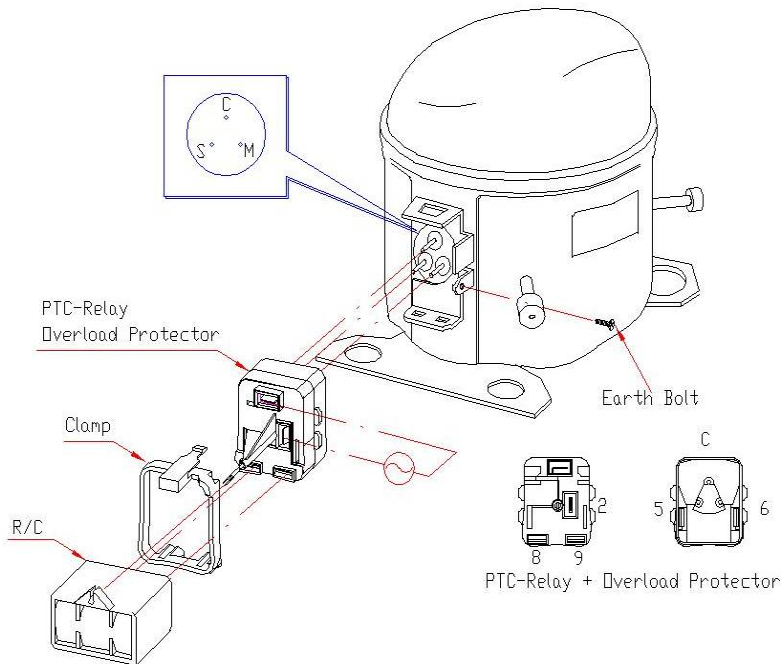

3-3. MSC 1

Wiring Diagram

Motor Type	RSIR	RSCR	CSIR	CSR
Running Capacitor	X	○	X	○
Starting Capacitor	X	X	○	○

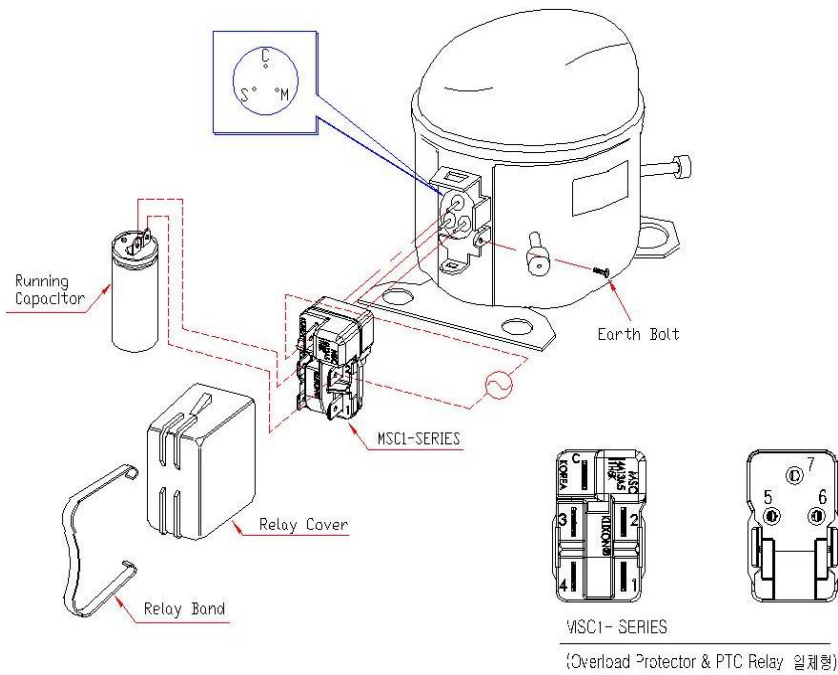

RSIR / RSCR

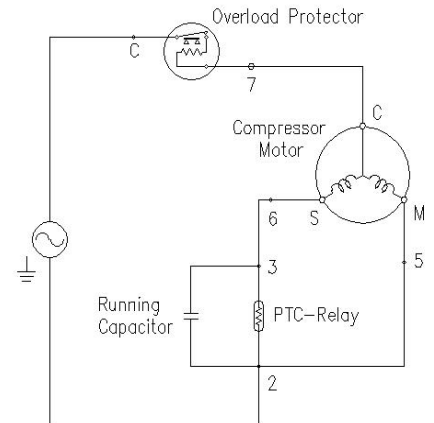

3-4. MSC-CF

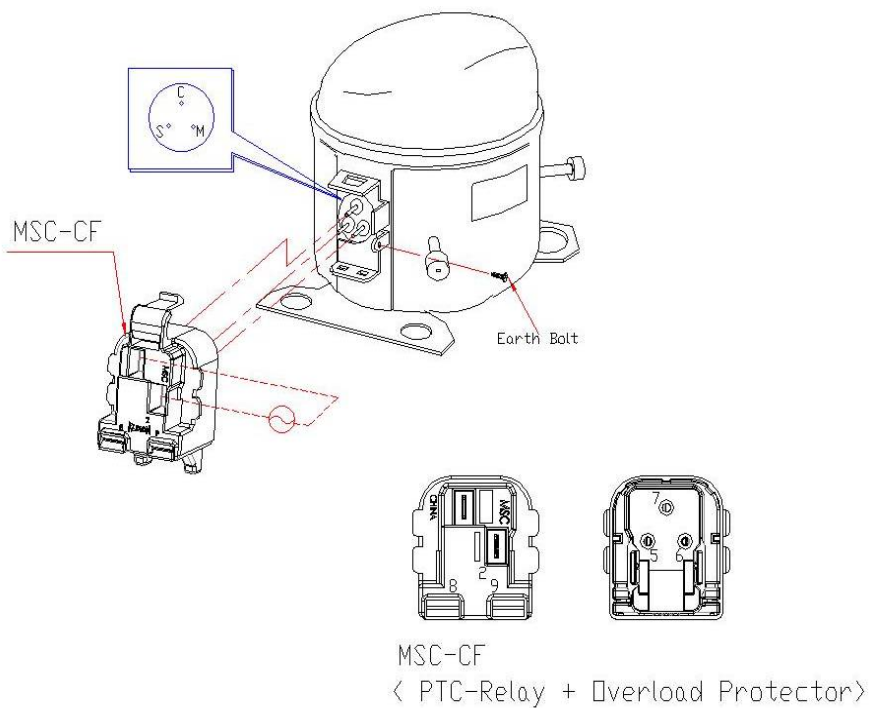

RSIR

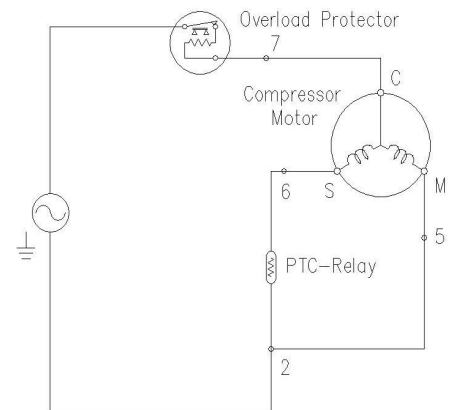

Mounting Accessory

Mounting Accessories

Bolt-Nut Type	Snap-On Type
BN54, BN74, BN170	S54, S74, S170

Comp Base

Series	H[mm]
DS, WX, Y	7.4
JE, JX	
YH, YX, YG, YE, DM, DH	17(5.4)
NW	7.8

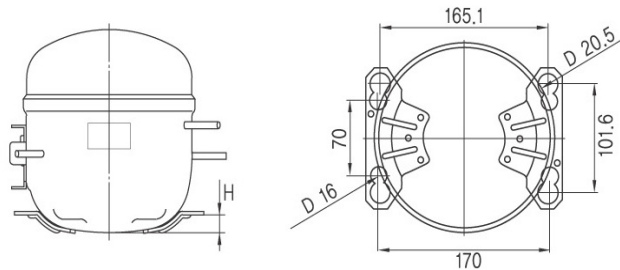

Mounting Accessory & Comp Base

Compressor Series	Type of Mounting Accessory	Comp Base		
		H[mm]	Hole Size	Position of Holes
YH, YX, YG, YE DM, DH	BN54, S54	5.4	Φ16	70 X 170
	BN170, S170	17		
DS, WX, Y, JE, JX	BN74, S74	7.4	Φ16 (Φ20.5)	70 X 170 (101.6 X 165.1)
NW		7.8		

Mounting Accessory & Comp Base

BN54	S54	BN74, S74	BN170, S170

Packing

1pc Box Size

Compressor Series	L1 [mm]	W1 [mm]	H1 [mm]
DS, WX, Y	219	233	170
JE, JX	219	233	190
YH, YX, YG, YE, DM, DH, NW	219	246	206

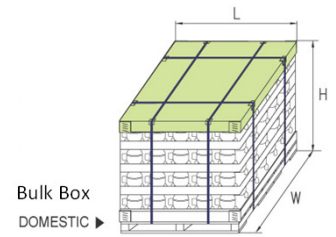
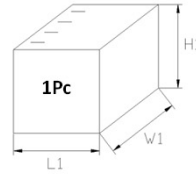

Bulk Box Size

Compressor Series	Bulk Box No	L [mm]	W [mm]	H [mm]
DS, WX, Y	①	1,162	988	978
JE, JX	②	1,162	988	847
YH, YX, YG, YE, DH, NW	③	1,162	1,040	937

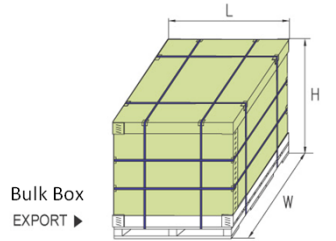

Compressor Quantity

Compressor Series	Bulk Box No	Comp Quantity / Bulk Box	Bulk Box Quantity / Container(20ft)	Comp Quantity / Container(20ft)	Remark
DS, WX	①	140	21	2,940	
Y	②	120	21	2,520	
JE, JX	③	96	21	1,920	
YH, YX, YG, YE,	④	96	20	1,920	
DH, NW	⑤	96 / 72	20	1,680	

Application Guide

1. Refrigerant R-12 (CCl ₂ F ₂) Purity ≥ 99.95% R-134a (CH ₂ F-CF ₃) Purity ≥ 99.5% R-600a (CH(CH ₃) ₂) Purity ≥ 99.5%		6. Suction gas temperature Similar range of super-heating with the ambient temperature(at the suction pipe 150mm location)	11. Moisture content 150mg max. in refrigeration system with a recommended drier
2. Evaporating temperature LBP -35℃ ~ -15℃ HBP(R-134a) -5℃ ~ 10℃		7. Shell temperature LBP : 100℃ max. in 43℃ test room HBP : 100℃ max. in 32℃ test room	12. Operating period ratio (On Period) / (On Period + Off Period) ≤ 65%
3. Condensing temperature LBP 60℃ max. 70℃ max. at peak load HBP(R-134a) 60℃ max. in 43℃ test room		8. Operating voltage LBP : Rated voltage ± 15% HBP : Rated voltage ± 10%	13. On period / Off period 5 minutes min.(On) / 5 minutes min.(Off)
4. Discharge gas temperature 120℃ max. in 43℃ test room		9. The amount of refrigerant charge Recommended amount based on the equalized cycle pressure	13. Evacuation of the refrigeration system Less than 0.5 torr
5. Motor winding temperature 120℃ max. in 43℃ test room Cu Winding temperature(T ₂) $T_2 = (R_2 / R_1) \times (234.5 + T_1) - 234.5$ Al Winding temperature(T ₂) $T_2 = (R_2 / R_1) \times (225 + T_1) - 225$ T ₁ : The room temperature R ₁ : The resistance at the beginning of the test R ₂ : The resistance at the end of the test		10. The amount of oil charge The compressors are supplied with proper oil charge	14. Installation Compressors should be installed in vertical direction within 5° inclination



CERTIFICATE



UL DQS Inc.
Management Systems Solutions

hereby certifies that the company

DAEWOO ELECTRONICS CORP.

Refrigerator Division
Washing Machine Division
Microwave Oven Division

981-1, Jangduk-Dong,
Kwangsan-Gu,
Kwangju 506-251 Korea

Compressor Division

988-1, Jangduk-Dong,
Kwangsan-Gu,
Kwangju 506-251 Korea

has implemented and maintains a **Quality Management System.**

Scope:

The design and manufacture of refrigerators including Kimchi refrigerator, washing machines and compressors.

The design and management of outsourced microwave oven manufacture.

Through an audit, documented in a report, it was verified that the management system fulfills the requirements of the following standard:

ISO 9001 : 2008

Certificate registration no. 20000665 QM08, 20000668 QM08

Date of certification 2010-08-09

Valid until 2013-08-08

Ganesh Rao
President

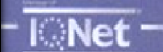

All design and specification are given as general information only and subject to change without prior notice for product improvement
2012. 09. 11

DAEWOO ELECTRONICS COMPRESSOR R&D TEAM Copy right reserved

