

COMMERCIAL REFRIGERATION COMPRESSORS



Emerson At-a-Glance

- Founded In 1890
- Presence In More Than 150 Countries (Manufacturing And Sales)
- 255 Manufacturing Locations, 165 Outside The U.S.
- FORTUNE 500 List Of America's Largest Corporations

Our Driving Force:

Vision

Emerson Climate Technologies, with our partners, will provide global solutions to improve human comfort, safeguard food and protect the environment.

Mission

To become the industry's steward and trusted partner by:

- Becoming an incredibly easy company to do business with through eBusiness and a culture of customer service
- Expanding our technology leadership position
- Using our broad capabilities in products and services to develop unique, high-value integrated solutions
- Being the best value provider for products and services
- Maintaining a work environment where our people and their ideas flourish





Headquarters in St. Louis, Mo.



Computer Aided Engineering Facility at Karad, India



Manufacturing Plant at Atit, India

About Emerson Climate Technologies (India) Limited

Emerson is a global Company that brings together technology and engineering to provide innovative solutions for our customers in a wide range of industrial, commercial and consumer markets. Our priority is to design, produce and deliver products, systems and solutions that make people's lives better.

Emerson Climate Technologies (India) Limited is offering innovative, energy efficient, environment friendly and reliable compressors to a broad range of customers across India and overseas, for the last four decades.

Fractional and Integral Horse Power compressors provide perfect cooling, creating value for its users. The compressors are manufactured in Atit Plant, which has state-of-the-art facilities and acclaimed to have “Gold Rating” under Emerson's Plant Technology Franchise Standards.

The performance of the compressors is optimized using CAE facilities. The components are sourced internationally and have been subjected to stringent Qualification Standards of Emerson Climate Technologies. The performance of compressors is validated by testing in a suitable appliance at an ambient of 46°C.

The countrywide Sales and Service network of Emerson Climate Technologies (India) Limited is positioned to provide prompt service to our Customers.



Product Approvals*



*For majority of the models.

Copeland Reciprocating Compressors

Partner For All Your Cooling Needs With Energy Efficient And Rugged Designs

FHP Applications

Low Back Pressure

- Chest Freezers
- Softy Machines
- Ice Cube Machine
- Centrifuge, Low Temp Baths
- Blood / Plasma Storage

Commercial Back Pressure

- Chest Coolers
- Display Cabinets
- Visi Coolers

High Back Pressure

- Water Coolers
- Air Dryers, Panel Coolers
- Oil Coolers



KCE 1/6 to 1/2 HP R22, R134a



KCN 1/6 to 1/2 HP R134a, R404A



KCJ 1/4 to 1HP R22, R134a, R404A



IHP Applications

Showcase

- Multi Deck
- Cabinet
- Island Freezer
- Cold Rooms
- Small Flake Ice Machines
- Environmental Chamber
- Clean Air Room
- Water Chiller
- Bulk Milk Cooler



KCJ 1 to 1 ¼ HP R22, R404A



CR6/KCM 1.3 to 3 ½ HP, R22, R134a, R404A

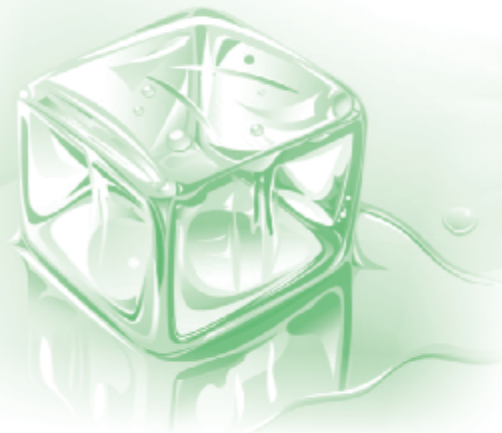

CRKQM 3 ½ to 5HP R22

KCX Series Compressor Nomenclature

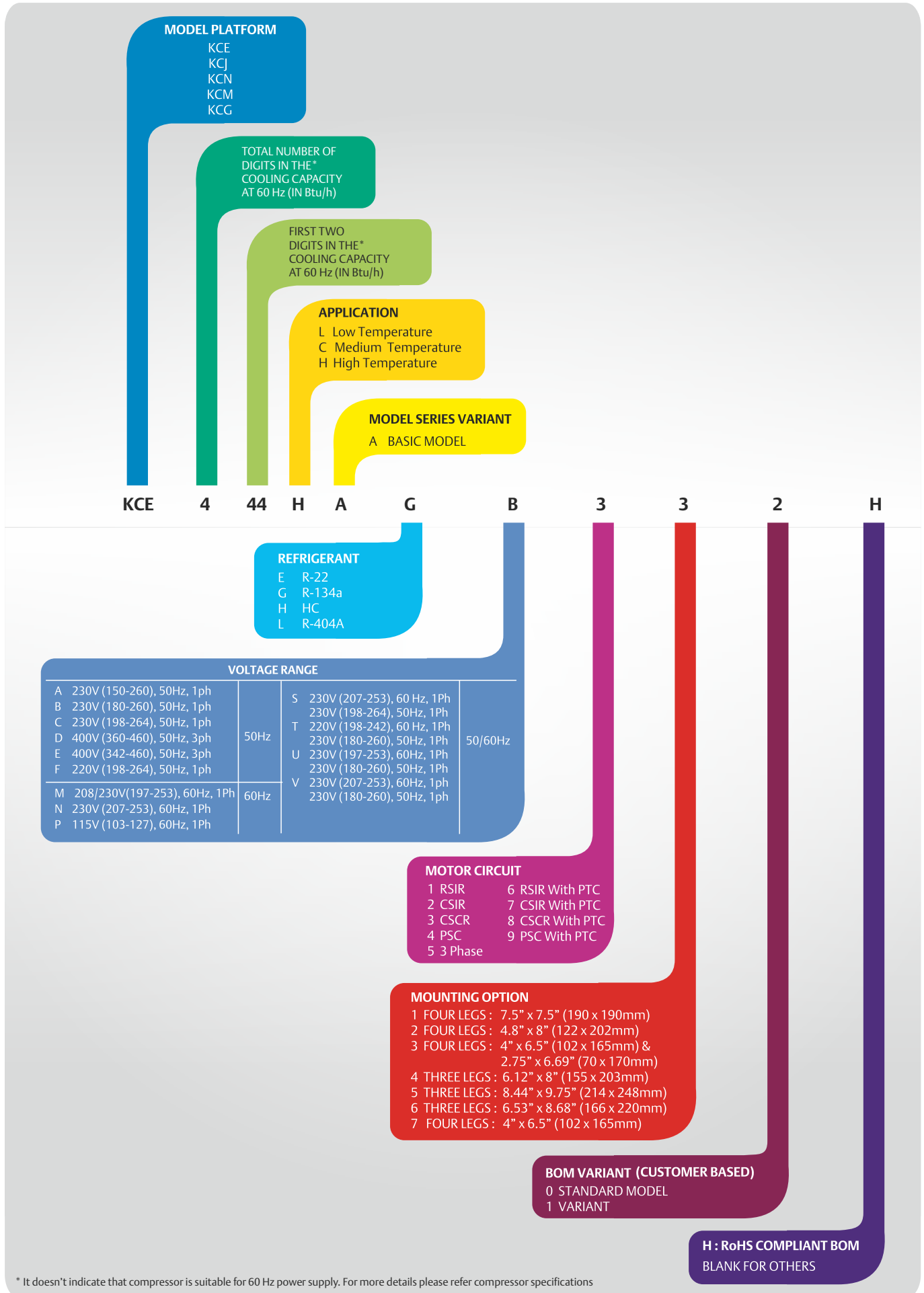

* It doesn't indicate that compressor is suitable for 60 Hz power supply. For more details please refer compressor specifications

CR Series Compressor Nomenclature

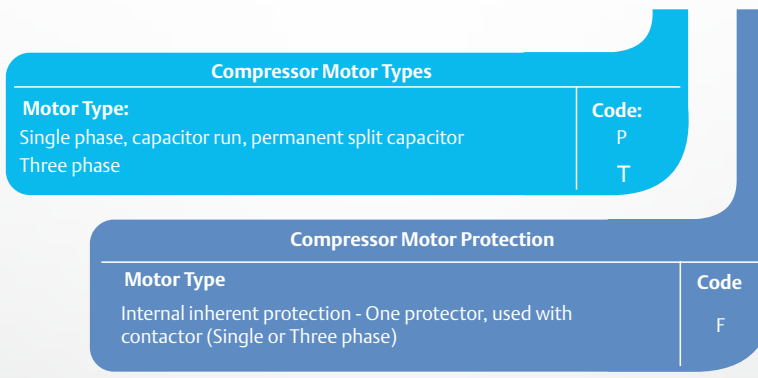
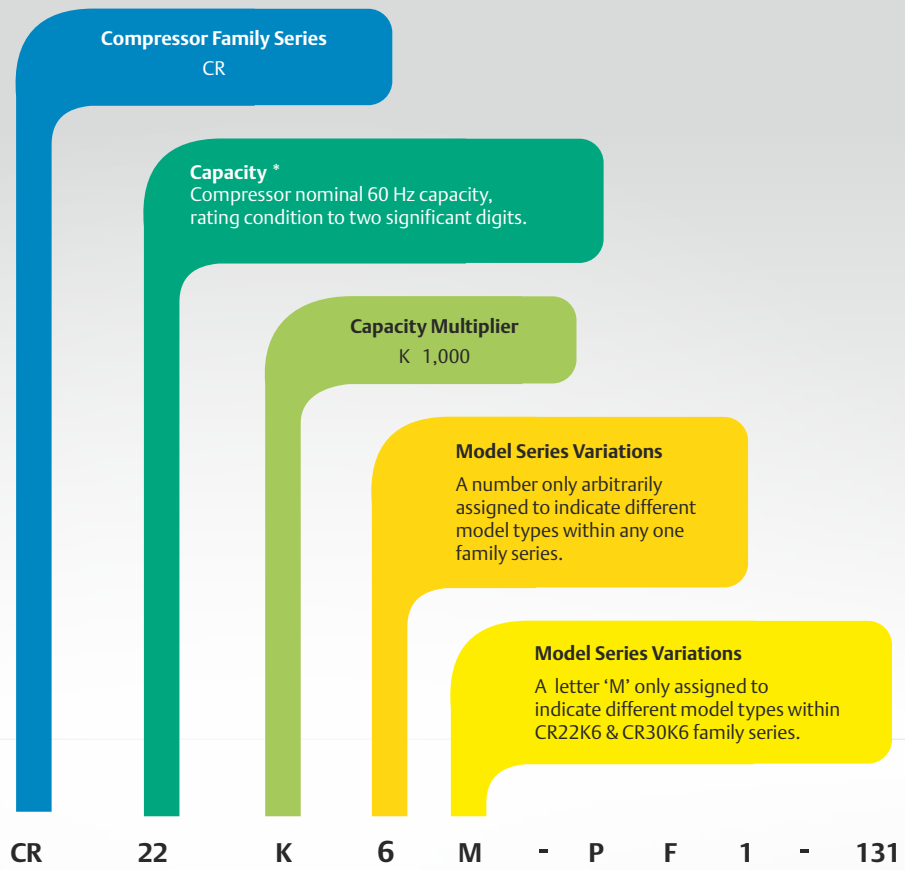

Electrical Codes

50Hz		60Hz		Code
Nominal Voltage & Phase	Operating Voltage Range	Nominal Voltage & Phase	Operating Voltage Range	
220-1	198-264	-	-	Z
230-1	180-260	-	-	1
400-3	340-460	-	-	5
400-3	360-460	-	-	6
400-3	342-462	-	-	M
400-3	342-462	-	-	D
		208/230-1	197-253	V

BOM Data

* Used for nomenclature purpose only. Refer specification for 60 Hz model selection.

Performance Nominals And Specifications

R22

High Temperature

Model	Hz	Displacement (CC/rev)	Performance at ASRE/T Rated Condition				Refrigeration Capacity (Watts) #						
			Capacity		Power	Current	Evap. Temp. / Cond. Temp. (°C)	-17.8	-15	-10	-5	0	5
			Btu/hr	W	W	A							
R22, 1Phase													
KCE443HAE	50	8.00	3,603	1,055	460	2.10	43.3	-	-	-	692	894	1,125
							54.4	-	-	-	543	731	919
KCE461HAE	50	11.50	5,102	1,494	625	2.90	43.3	-	-	-	1,047	1,323	1,649
	60		6,103	1,787	740	3.30	54.4	-	-	-	840	1,082	1,347
KCJ511HAE	50	18.27	9,150	2,681	1,020	4.70	43.3	-	-	-	1,246	1,574	1,964
	60		10,505	3,076	1,175	5.30	54.4	-	-	-	1,001	1,289	1,605
KCJ513HAE	50	25.91	12,806	3,750	1,440	6.80	43.3	1,605	1,732	1,981	2,422	3,065	3,772
	60		14,507	4,248	1,720	7.96	54.4	1,306	1,419	1,681	2,067	2,573	3,220
CR22K6M-PF1	50	40.80	18,963	5,553	1,750	7.80	43.3	1,830	2,001	2,258	2,761	3,494	4,301
							54.4	1,489	1,618	1,917	2,357	2,933	3,671
CR30K6M-PF1	50	51.47	24,870	7,283	2,350	11.00	43.3	1,421	1,909	2,803	3,740	4,783	6,017
							54.4	-	-	2,065	2,912	3,822	4,881
CR36K6-PFZ	50	59.65	30,051	8,800	2,720	13.60	43.3	2,021	2,559	3,666	4,946	6,340	7,916
							54.4	-	-	2,734	3,915	5,162	6,572
CR42K6-PFZ	50	72.08	36,103	10,572	3,240	15.40	43.3	2,412	3,120	4,526	5,965	7,563	9,366
							54.4	-	-	3,264	4,774	6,220	7,847
CR47KQM-PFZ	50	82.74	41,752	12,226	3,950	20.00	43.3	3,203	3,882	5,300	7,018	9,014	11,282
	60		48,729	14,269	4,650	22.00	54.4	2,842	3,992	6,091	8,285	10,560	12,932
CR47KQM-PFV	60						43.3	4,248	5,406	7,489	9,732	12,311	15,179
							54.4	-	-	6,004	8,034	10,261	1,2720
R22, 3 Phase													
CR22K6M-TFM	50	40.80	18,254	5,345	1,750	3.20	43.3	1,574	1,906	2,649	3,571	4,666	5,952
							54.4	-	-	1,930	2,733	3,690	4,805
CR30K6M-TFM	50	51.47	24,307	7,118	2,275	4.20	43.3	2,050	2,647	3,697	4,857	6,132	7,638
							54.4	-	-	2,773	3,787	4,893	6,224
CR36K6-TF6	50	59.66	29,844	8,739	2,680	4.90	43.3	2,556	3,222	4,496	5,931	7,515	9,301
							54.4	-	-	3,405	4,744	6,188	7,796
CR42K6-TF5	50	72.09	35,077	10,272	3,300	6.10	43.3	3,382	4,014	5,367	6,979	8,823	10,977
							54.4	-	-	4,231	5,594	7,227	9,114
CR47KQM-TFD	50	78.78	40,692	11,916	3,825	6.90	43.3	4,583	5,325	6,756	8,387	10,227	12,522
	60		48,379	14,167	4,550	6.80	54.4	-	-	5,722	7,239	8,986	10,791
CR53KQM-TFD	50	88.28	45,816	13,416	4,350	7.70	43.3	5,534	6,431	8,170	10,148	12,351	15,110
	60		54,326	15,908	5,200	7.50	54.4	-	-	6,901	8,746	10,883	13,028
CR57KQM-TFD	50	94.61	48,995	14,347	4,650	8.30	43.3	5,805	6,785	8,682	10,860	13,321	16,304
	60		58,425	17,108	5,550	8.10	54.4	-	-	7,405	9,380	11,660	14,216
CR62KQM-TFD	50	101.92	52,789	15,458	5,100	8.80	43.3	4,450	5,551	7,517	9,767	12,568	15,370
	60		62,832	18,399	6,075	8.70	54.4	-	-	7,405	9,380	11,660	14,216
KCG572HAE	50	133.22	59,814	17,515	6,100	10.20	43.3	5,805	6,785	8,682	10,860	13,321	16,304
								54.4	-	-	6,822	9,340	12,353
							43.3	5,860	6,878	8,695	10,794	13,442	16,089
							54.4	-	-	7,416	9,375	11,714	14,052
							43.3	7,091	8,320	10,516	13,061	16,283	19,506
							54.4	-	-	8,964	11,294	14,022	16,750
							43.3	-	-	-	12,104	15,577	19,779
							54.4	-	-	-	8,875	12,008	15,756



		Mechanical Specification			Electrical Specification								
10	12.8	Oil Charge(cc)	Cooling Type (CFM)	Net Wt. (Kg.)	LRA (A)	Voltage Range(V)	Motor Type	Fig No.	Start Capacitor (Mfd)	Run Capacitor (Mfd)	Relay		OLP
											Potential / PTC	Current	
1,503	1,706	310	Fan 350	11.80	13	180-260	PSC / CSCR*	1/4	40/60	10	LT85002 or HLR3800-4L3C-2	-	KAT0072/K3 or MRA12309-12103
1,222	1,441												
2,016	2,250	510	Fan 350	13.40	17	180-260	PSC / CSCR*	1/4	60/80*	15	LT85003* or HLR3800-4L3C-3	-	KAT0733/B2 or KAT0159/B2
1,693	1,912												
2,399	2,678												
2,025	2,275												
3,750	4,265	905	Fan 350	21.50	25	180-260	PSC / CSCR*	1/4	80/100*	25	LT85002* or HLR3800-4L3C-2	-	Internal
3,135	3,618												
4,350	4,947												
3,636	4,196												
4,869	5,435	890	Fan 350	22.50	30	198-264	PSC / CSCR*	1/4	80/100*	36	AC85001* or HLR3800-6H3C-1	-	Internal
4,337	4,858												
5,551	6,195												
4,944	5,538												
7,501	8,529	1,330	Fan 400	29.80	54	180-260	PSC / CSCR*	1/4	80/100*	36	AC85004	-	Internal
6,182	7,059												
9,640	10,735	1,330	Fan 400	32.50	72	180-260	PSC / CSCR	1/4	150/200	45	AC85001	-	Internal
8,116	9,088												
11,398	12,735	1,330	Fan 400	34.90	85	198-264	CSCR	4	130/156	40 or 45	AC85004	-	Internal
9,640	10,853												
13,712	15,294	1,330	Fan 400	34.90	104	198-264	CSCR	4	189/227	60 or 65	AC85005	-	Internal
11,573	12,912												
15,763	17,023	1,330	Fan 400	36.00	110	198-264	CSCR	4	189/227	60	AC85005	-	Internal
13,331	14,679												
18,400	20,363												
15,617	1,728												
7,354	8,235	1,330	Fan 400	29.50	20	342-462	3 Ph	-	-	-	-	-	Internal
6,036	6,794												
9,464	10,706	1,330	Fan 400	30.00	28	342-462	3 Ph	-	-	-	-	-	Internal
7,823	8,941												
11,280	12,559	1,330	Fan 400	31.00	41	360-460	3 Ph	-	-	-	-	-	Internal
9,552	10,647												
13,478	15,088	1,330	Fan 400	32.70	45	340-460	3 Ph	-	-	-	-	-	Internal
11,280	12,735												
15,038	16,639	1,330	Fan 400	36.20	60	342-462	3 Ph	-	-	-	-	-	Internal
13,198	14,630												
18,142	20,076												
15,994	17,723												
19,718	21,856	1,330	Fan 400	36.20	61	342-462	3 Ph	-	-	-	-	-	Internal
17,469	19,191												
19,718	21,856												
17,469	19,191												
18,492	20,380	1,330	Fan 400	36.20	61	342-462	3 Ph	-	-	-	-	-	Internal
16,695	17,393												
21,845	24,129												
18,712	20,732												
19,190	21,126	1,330	Fan 400	36.20	55	342-462	3 Ph	-	-	-	-	-	Internal
16,911	18,740												
21,747	22,570												
20,315	22,681												
24,495	27,588	2,250	Fan 420	51.40	55	360-460	3 Ph	-	-	-	-	-	Internal
20,158	22,941												

* These are optional

Note

Model	Return Gas Temperature (°C)	Subcooled Liquid Temperature (°C)
KCE, KCN, KCJ	35	46.1
CR, KCM, KCG	18.3	46.1
KCM475LAL, 515LAL	32	46.1

Performance Nominals And Specifications

R134a High Temperature

Model	Hz	Displacement (CC/rev)	Performance at ASRE/T Rated Condition				Refrigeration Capacity (Watts) #						
			Capacity		Power	Current	Evap. Temp. / Cond. Temp. (°C)	-17.8	-15	-10	-5	0	5
			Btu/hr	W	W	A							
R134a, 1Phase													
KCE419HAG	50	5.79	1,588	465	245	1.40	43.3	184	219	271	322	457	558
	60		1,861	545	282	1.50	54.4	144	166	213	262	322	415
KCE425HAG	50	7.58	2,145	628	360	2.30	43.3	215	257	317	384	476	608
	60		2,438	714	380	2.20	54.4	169	194	250	306	377	486
KCE432HAG	50	9.42	2,691	788	375	2.75	43.3	259	289	347	417	517	669
	60		3,227	945	470	2.75	54.4	192	229	280	337	419	547
KCE444HAG	50	12.05	3,678	1,077	450	2.00	43.3	294	329	395	474	588	761
	60		4,276	1,252	535	2.20	54.4	219	260	318	383	476	622
KCJ444HAG	50	12.58	3,702	1,084	450	2.80	43.3	213	287	417	547	675	832
	60		4,276	1,252	535	2.20	54.4	138	201	315	427	539	676
KCN463HAG	50	15.33	5,252	1,538	615	2.70	43.3	256	344	500	656	810	997
	60		6,304	1,846	810	3.65	54.4	166	241	378	513	647	811
KCJ467HAG	50	18.27	5,604	1,641	675	3.90	43.3	412	480	596	737	931	1,176
	60		6,704	1,963	820	4.10	54.4	294	373	489	611	771	962
KCJ498HAG	50	25.91	8,203	2,402	975	5.90	43.3	479	558	694	858	1,084	1,368
	60		9,255	2,710	1,120	6.10	54.4	342	434	569	711	897	1,120
KCM511CAL	50	40.80	11,275	3,302	1,125	5.30	43.3	365	414	523	665	876	1,198
	60		13,227	3,945	1,270	5.70	54.4	282	340	444	552	703	939
KCM514CAL	50	51.47	15,273	4,472	1,515	7.50	43.3	-	-	-	1,111	1,343	1,644
	60		17,273	5,163	1,710	8.10	54.4	-	-	-	966	1,175	1,424
KCM519CAL	50	59.65	18,655	5,463	1,800	9.75	43.3	-	-	-	1,236	1,534	1,929
	60		21,320	6,243	2,030	10.30	54.4	-	-	-	1,069	1,342	1,670
KCM522CAL	50	72.08	21,320	6,243	2,030	9.80	43.3	527	638	864	1,132	1,430	1,780
	60		24,320	7,243	2,330	10.40	54.4	414	498	681	910	1,170	1,483
KCM519CAL	50	59.65	18,655	5,463	1,800	9.75	43.3	627	759	1,029	1,347	1,702	2,119
	60		21,320	6,243	2,030	10.30	54.4	492	592	811	1,083	1,393	1,765
KCM522CAL	50	72.08	21,320	6,243	2,030	9.80	43.3	1,115	1,185	1,355	1,627	2,049	2,567
	60		24,320	7,243	2,330	10.40	54.4	909	978	1,101	1,333	1,688	2,149
KCM511CAL	50	40.80	11,275	3,302	1,125	5.30	43.3	1,267	1,347	1,540	1,849	2,328	2,917
	60		13,227	3,945	1,270	5.70	54.4	1,025	1,103	1,251	1,515	1,918	2,442
KCM514CAL	50	51.47	15,273	4,472	1,515	7.50	43.3	864	1,114	1,606	2,209	2,942	3,807
	60		17,273	5,163	1,710	8.10	54.4	551	775	1,211	1,734	2,370	3,074
KCM519CAL	50	59.65	18,655	5,463	1,800	9.75	43.3	1,019	1,336	1,981	2,763	3,657	4,737
	60		21,320	6,243	2,030	10.30	54.4	608	884	1,437	2,116	2,930	3,800
KCM522CAL	50	72.08	21,320	6,243	2,030	9.80	43.3	1,172	1,571	2,358	3,299	4,409	5,771
	60		24,320	7,243	2,330	10.40	54.4	699	1,029	1,706	2,544	3,432	4,335
KCM519CAL	50	59.65	18,655	5,463	1,800	9.75	43.3	1,442	1,876	2,739	3,788	5,041	6,530
	60		21,320	6,243	2,030	9.80	54.4	939	1,310	2,058	2,985	4,090	5,406
R134a, 3 Phase													
KCM519CAL	50	59.65	18,655	5,463	1,800	9.75	43.3	1,172	1,571	2,358	3,299	4,409	5,771
							54.4	699	1,029	1,706	2,544	3,432	4,335
KCM522CAL	50	72.08	21,320	6,243	2,030	9.80	43.3	1,442	1,876	2,739	3,788	5,041	6,530
							54.4	939	1,310	2,058	2,985	4,090	5,406





		Mechanical Specification			Electrical Specification															
10	12.8	Oil Charge(cc)	Cooling Type (CFM)	Net Wt. (Kg.)	LRA (A)	Voltage Range(V)	Motor Type	Fig No.	Start Capacitor (Mfd)	Run Capacitor (Mfd)	Relay		OLP							
											Potential / PTC	Current								
677	800	310	Fan 350	10.20	12	180-260	RSIR	3	-	-	-	KARP3627	TAE19/H3							
557	662				11	207-253														
792	936																			
652	774																			
891	1,059	310	Fan 350	10.80	13	180-260	CSIR	6	40/60	-	-	KARP4241	KAT0072/H3 or MRA12309-12101							
741	891				207-253															
1,013	1,204																			
843	1,014																			
1,157	1,388	310	Fan 350	11.80	12.5	180-260	CSIR	6	40/60	-	-	KARP4241 / MTRP4241	KAT0072/H3 or MRA12309-12101							
984	1,188				207-253															
1,388	1,664																			
1,180	1,424																			
1,573	1,876	310	Fan 350	11.80	13	180-260	CSCR	4	40/60	10	LT85002 OR HLR3800-4I3C-2	-	KAT0072/H3							
1,283	1,535				207-253															
1,830	2,183																			
1,493	1,786																			
1,658	2,018	890	Fan 350	20.20	17	180-260	CSIR	6	80/100	-	-	KARP4841 / MTRP4841	KAT0159/B2							
1,286	1,568																			
2,027	2,312																			
1,749	1,974																			
2,392	2,728	380	Fan 350	11.50	14	180-260	CSCR	4	80/100	15	LT85002 or HLR3800-4L3C-2	-	KAT0463/B2 / MRA12308-12102							
2,064	2,329				197-253															
2,206	2,494																			
1,878	2,147																			
2,626	2,968	890	Fan 350	21.00	23	180-260	CSIR	6	80/100	-	-	KARP-5641 / MTRP-5641 MTRP5941	KAT0733/B2							
2,247	2,569				198-242															
3,182	3,596																			
2,708	3,108																			
3,616	4,086	890	Fan 350	21.50	32	198-264	CSIR	5	80/100	-	AC85001 or HLR3800-6H3C-1	-	KAT0163 / B2							
3,077	3,518				207-253															
4,831	5,570																			
4,033	4,703																			
6,059	7,044	1,330	Fan 400	32.50	72	180-260	CSCR	4	150/200	45	AC85001 / HLR3800-6H3C-1	-	Internal							
5,055	5,890																			
7,450	8,541																			
6,199	7,204																			
8,292	9,600	1,330	Fan 400	34.90	85	180-260	CSCR	4	130/156	40	AC85004 / 3ARR3 CT3P5 / RVA-3F6D	-	Internal							
6,994	8,148				104	180-260								CSCR	4	189/227	60	AC85005 / 3ARR3C T24S5 / RVA-3AG 6D	-	Internal
7,450	8,541																			
6,199	7,204																			
8,292	9,600	1,330	Fan 400	37.00	45	342-460	3 Ph	-	-	-	-	Internal								
6,994	8,148																			
7,450	8,541																			
6,199	7,204																			
8,292	9,600	1,330	Fan 400	37.00	45	342-460	3 Ph	-	-	-	-	Internal								
6,994	8,148																			
7,450	8,541																			
6,199	7,204																			

Permitted Evaporating Temperature Range in °C

Model	Refrigerant	High Temperature	Medium Temperature	Low Temperature
KCJ, KCE, KCN, KCM	R134a	-17.8 to 12.8*	-17.8 to 12.9	-28.8 to -6.7**
KCG, CR, KCJ, KCE	R22	-6.7 to 12.8	N.A.	N.A.
KCN, KCJ, KCM	R404A	N.A.	-17.8 to 10.0	-40.0 to -6.7

* Except KCN463HAG / KCJ498HAG : -6.7 °C to 12.8 °C

** Except KCN : -37 °C to -6.7 °C

Note : Condensing temperature range for all models except CR = 37.8°C to 60°C and for CR please refer individual model specification.

Performance Nominals And Specifications

R134a

R404A

Medium Temperature

Model	Hz	Displacement (CC/rev)	Performance at ASRE/T Rated Condition				Refrigeration Capacity (Watts) #						
			Capacity		Power	Current	Evap. Temp. / Cond. Temp. (°C)	-17.8	-15	-10	-5	0	5
			Btu/hr	W	W	A							
R134a, 1Phase													
KCN413CAG	50	6.15	1,079	316	180	0.80	43.3	268	301	355	424	518	613
	60		1,240	363	205	0.80	54.4	235	243	289	355	446	538
KCN416CAG	50	7.31	1,342	393	220	1.00	43.3	307	346	408	486	594	704
	60		1,540	451	250	1.10	54.4	270	279	331	407	512	618
	50		43.3	284	328	409	511	627	763				
	60		43.3	236	271	342	431	535	655				
	50		43.3	326	377	470	588	721	876				
	60		54.4	271	312	393	496	615	753				
R404A, 1Phase													
KCJ422CAL	50	8.00	1,800	527	400	2.40	43.3	405	472	603	754	922	1,108
							54.4	290	346	451	582	736	899
KCJ438CAL	50	11.50	3,203	938	625	3.70	43.3	639	745	952	1,189	1,455	1,749
							54.4	459	545	712	919	1,161	1,418
KCJ461CAL	50	18.27	5,102	1,494	925	4.10	43.3	1,147	1,338	1,709	2,134	2,612	3,139
							54.4	824	979	1,279	1,649	2,085	2,545
KCJ484CAL	50	25.91	7,004	2,051	1,250	6.20	43.3	1,571	1,833	2,341	2,924	3,579	4,287
							54.4	1,128	1,341	1,752	2,259	2,856	3,487
KCM511CAL	50	40.80	8,975	2,628	1,385	6.30	43.3	-	2,022	2,812	3,788	4,945	6,284
							54.4	-	-	2,063	2,870	3,826	4,966
KCM514CAL	50	51.47	11,947	3,498	1,840	8.70	43.3	-	2,666	3,675	4,927	6,389	8,079
							54.4	-	-	2,772	3,834	5,054	6,493
KCM519CAL	50	59.65	16,025	4,692	2,360	12.30	43.3	-	3,780	4,998	6,480	8,204	10,203
							54.4	-	-	3,806	5,039	6,485	8,194
KCM522CAL	50	72.08	18,205	5,331	2,600	12.00	43.3	-	4,600	5,900	7,490	9,393	11,770
							54.4	-	-	4,331	5,756	7,471	9,608
R404A, 3 Phase													
KCM511CAL	50	40.80	9,484	2,777	1,380	2.40	43.3	-	1,904	3,219	4,217	5,347	6,438
							54.4	-	-	2,171	3,069	3,988	5,153
KCM514CAL	50	51.47	13,051	3,822	1,865	3.50	43.3	-	2,824	4,685	6,087	7,524	9,028
							54.4	-	-	3,088	4,315	5,754	7,144
KCM519CAL	50	59.65	15,776	4,620	2,325	4.70	43.3	-	3,692	4,922	6,368	8,107	10,113
							54.4	-	-	3,729	4,950	6,381	8,104
KCM522CAL	50	72.08	18,275	5,352	2,600	5.20	43.3	-	4,600	5,900	7,490	9,393	11,770
							54.4	-	-	4,330	5,756	7,471	9,500

		Mechanical Specification				Electrical Specification							
10	12.8	Oil Charge(cc)	Cooling Type (CFM)	Net Wt. (Kg.)	LRA (A)	Voltage Range(V)	Motor Type	Fig No.	Start Capacitor (Mfd)	Run Capacitor (Mfd)	Relay		OLP
											Potential / PTC	Current	
759	-	340	Fan 350	9.70	8	180-260	CSCR	4	40/60	6	PTC-8EA19D7	-	KAT0411/ H3
656	-					207-253							
871	-												
754	-												
914	-												
794	-	340	Fan 350	9.70	10	180-260	CSCR	4	40/60	6	PTC-8EA19D7	-	KAT0413 / H3 or MRA 12390-12101
1,051	-					207-253							
912	-												
1,385	-	890	Fan 350	20.00	16	180-260	CSIR	6	80/100	-	-	KARP4741	KAT0463 / B2
1,146	-												
2,185	-	890	Fan 350	21.50	24	180-260	CSIR	6	80/100	-	-	KARP5641 / MTRP5641	T0732/B9
1,808	-												
3,922	-	890	Fan 350	21.50	25	180-260	CSCR	4	80/100	25	LT85002 or HLR3800-413C-2	-	Internal
3,246	-												
5,373	-	890	Fan 350	22.50	37	180-260	CSCR	4	80/100	25	AC85001 OR HLR3800-6H3C-1	-	Internal
4,448	-												
7,823	8,647	1,330	Fan 400	29.80	54	180-260	CSCR	4	80/100	36	AC85004	-	Internal
6,241	6,912												
10,064	10,971	1,330	Fan 400	32.50	72	180-260	CSCR	4	150/200	45	AC85001 or HLR3800-6H3C-1	-	Internal
8,204	8,971												
12,511	13,588	1,330	Fan 400	34.90	85	180-260	CSCR	4	120/150	45	AC85004 or 3ARR3CT3P5 or RVA-3F6	-	Internal
10,174	11,076												
14,562	15,792	1,330	Fan 400	34.90	104	180-260	CSCR	4	120/150	60	AC85005 or 3ARR3CT2455 or RVA-3AG 6D	-	Internal
11,822	12,774												
7,471	7,684	1,330	Fan 400	29.50	20	342-462	3 Ph	-	-	-	-	-	Internal
6,206	6,630												
10,943	11,903	1,330	Fan 400	30.00	28	342-462	3 Ph	-	-	-	-	-	Internal
9,082	9,963												
12,432	13,449	1,330	Fan 400	31.00	41	342-460	3 Ph	-	-	-	-	-	Internal
10,086	10,943												
14,561	15,792	1,330	Fan 400	32.70	45	342-460	3 Ph	-	-	-	-	-	Internal
11,822	12,774												

Notes

- Electrical rating is 230 V, 50 Hz and 230 V, 60 Hz for single phase models and, 400 V, 50 Hz for three phase models.
- Operating voltage range signifies the range of voltage for which the compressor can start and run up to 43° Cambient.
- Cooling capacity and power consumption are nominal values at specified rating conditions and subject to ±5% variation.
- Direct air flow on glass terminal cover should be avoided.
- Compressors with CSIR, CSCR circuit and three phase models may be used with thermostatic expansion valve.
- Compressors with RSIR Circuit must use capillary tube only.
- All compressors use two pole motors.
- Compressors for specific applications are rated for IS-10617 Part I and Part III-1983.
- All run capacitor should have a rating of 440 VAC and start capacitor 275 VAC surge, unless otherwise specified by Emerson Climate Technologies (India) Limited.

Performance Nominals And Specifications

R134a

R404A

Low Temperature

Model	Hz	Displacement (CC/rev)	Performance at ASRE/T Rated Condition				Refrigeration Capacity (Watts) #						
			Capacity		Power	Current	Evap. Temp. / Cond. Temp. (°C)	-37.2	-35	-30	-25	-20	-15
			Btu/hr	W	W	A							
R134a, 1 Phase													
KCN372LAG	50	7.31	601	176	159	1.34	43.3	80	94	130	181	246	321
							54.4	76	86	115	162	223	294
KCN396LAG	50	9.00	803	235	205	1.85	43.3	-	115	174	247	323	403
							54.4	-	107	157	215	276	343
KCN411LAG	50	11.10	963	282	245	2.10	43.3	-	135	207	297	396	515
							54.4	-	106	177	255	348	467
KCJ412LAG	50	16.35	1,028	301	280	2.75	43.3	-	-	-	358	500	683
							54.4	-	-	-	260	405	583
KCN415LAG	50	15.33	1,267	371	325	1.80	43.3	-	150	259	373	509	677
							54.4	-	112	210	328	466	625
KCJ423LAG	50	32.61	1,933	566	485	3.00	43.3	-	-	-	661	943	1,267
							54.4	-	-	-	486	740	1,016
R404A, 1 Phase													
KCN414LAL	50	7.31	1,150	337	325	2.30	43.3	166	198	263	354	458	578
							54.4	137	159	222	307	399	506
KCN418LAL	50	9.00	1,455	426	385	2.00	43.3	205	257	354	470	607	759
							54.4	178	203	276	385	504	637
KCN422LAL	50	11.10	1,834	537	455	2.20	43.3	256	321	443	588	759	949
							54.4	225	255	348	486	635	802
KCN430LAL	50	15.33	2,575	754	580	4.40	43.3	364	454	626	831	1,074	1,342
							54.4	317	359	489	682	892	1,127
KCJ430LAL	50	16.35	2,435	713	580	3.20	43.3	304	389	550	747	977	1,232
							54.4	222	293	460	647	865	1,125
KCJ450LAL	50	32.64	4,118	1,206	1,000	5.50	43.3	416	591	934	13,25	1,771	2,235
							54.4	273	438	727	1,079	1,512	1,992
KCM475LAL	50	51.47	5,703	1,670	1,250	6.80	43.3	876	1,068	1,490	1,880	2,514	3,298
							54.4	-	-	1,114	1,529	2,205	2,974
R404A, 3 Phase													
KCM515LAL	50	89.68	12,506	3,662	2,460	5.10	43.3	1,933	2,344	3,238	4,057	5,044	6,242
							54.4	-	-	2,611	3,395	4,267	5,307



		Mechanical Specification			Electrical Specification								
-10	-6.7	Oil Charge(cc)	Cooling Type (CFM)	Net Wt. (Kg.)	LRA (A)	Voltage Range(V)	Motor Type	Fig No.	Start Capacitor (Mfd)	Run Capacitor (Mfd)	Relay		OLP
											Potential / PTC	Current	
404	462	340	Oil / Fan 260	10.20	10	180-260	CSIR	6	40/60	-	-	KARP-3141/ MTRP-3141 KARP3227	TAE15/H3
377	438						RSIR	3					
488	547	340	Oil / Fan 260	10.20	10	180-260	CSIR	6	40/60	-	-	KARP 4141/ MTRP 4141	TAE5M/H3
418	471												
653	750	380	Fan 350	11.50	10	180-160	CSIR	6	40/60	-	-	KARP4241/ MTRP4241	KAT0072/H3 OR MRA12309-12101
604	699												
907	1068	890	Fan 350	21.00	24	180-260	CSIR	6	80/100	-	-	MTRP 4841/ KARP4841	KAT0159/B2
802	968												
867	1,000	380	Fan 350	11.50	14	180-260	CSCR	4	80/100	10	-	KARP-4941	KAT0072/H3 or MRA-12309-12101
805	932												
1,683	2,000	890	Fan 350	22.50	30	198-264	CSCR	4	150/200	10	LT85003	-	T0732/B2 or KAT0732/B2
1,390	1,712												
727	838	340	Fan 350	10.20	16	180-260	CSIR	6	60/80	-	-	KARP- 4241	KAT0072/ H3 or MRA2309-12101
640	738												
934	1,065	380	Fan 350	11.50	14	180-260	CSCR	4	80/100	10	LT85002 or HLR3800-413C-2	-	KAT0072/B2 or MRA12309-12102 or T0072/B2
806	938												
1,168	1,331	380	Fan 350	11.50	17	180-260	CSCR	4	80/100	15	LT85003 or HLR3800-4L3C-3	-	KAT0164/ B2 OR T0164/K9
1,015	1,182												
1,652	1,883	420	Fan 350	12.50	18	180-260	CSCR	4	80/100	15	LT85003 or HLR3800-4L3C-3	-	KAT0733/ B2
1,426	1,660												
1,474	1,612	890	Fan 350	22.50	30	180-260	CSCR	4	150/200	10	LT85003 or HLR3800-4L3C-3	-	Internal
1,381	1,524												
2,698	3,003	890	Fan 350	25.00	50	180-260	CSCR	4	150/200	25	AC85005	-	Internal
2,476	2,788												
4,236	4,966	1,300	Fan 350	32.50	72	198-264	CSCR	4	150/200	25	AC 85004	-	Internal
3,785	4,386												
7,650	8,666	1,300	Fan 350	32.70	45	342-460	3 Ph	-	-	-	-	-	Internal
6,616	7,618												

ASRE/T Rating Conditions

Ambient Temperature	Evaporating Temperature	Condensing Temperature	Sub Cooled Liquid Temp	Suction Gas Temperature	Suction Pressure			Discharge Pressure		
					R134a	R22	R404A	R134a	R22	R404A
°C	°C	°C	°C	°C	psig	psig	psig	psig	psig	psig
High Temperature										
35	7.2	54.4	46.1	35	40	77	93.7	196	300	354
Medium Temperature										
35	-6.7	54.4	46.1	35	18	----	55.6	196	----	354
Low Temperature										
32	-23.3	54.4	32	32	1.9	----	24.6	196	----	354

Medium Temperature (R404A)

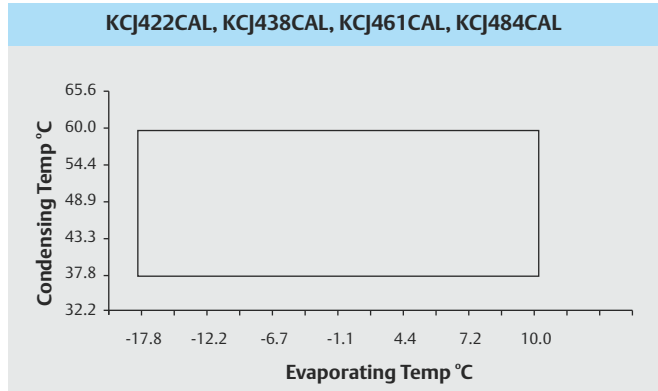
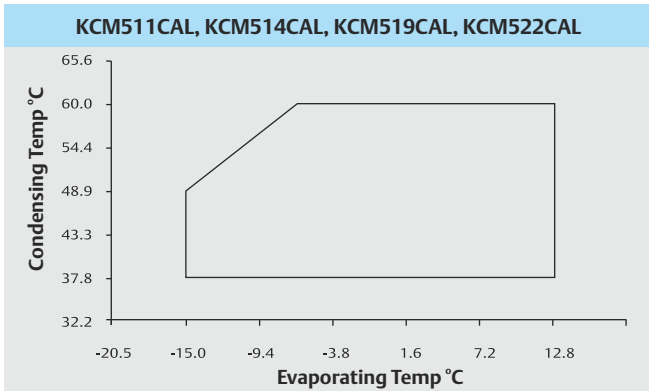

Low Temperature (R134a)

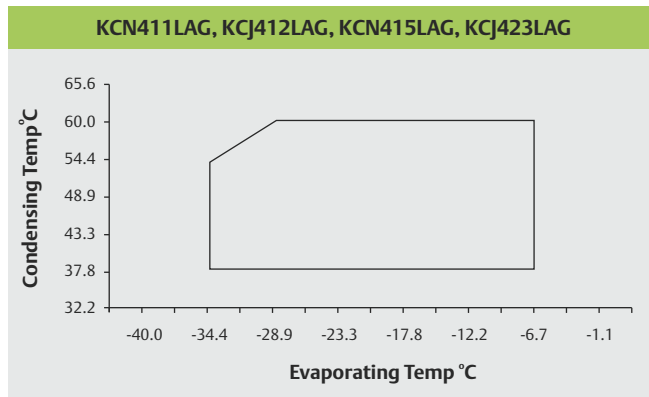
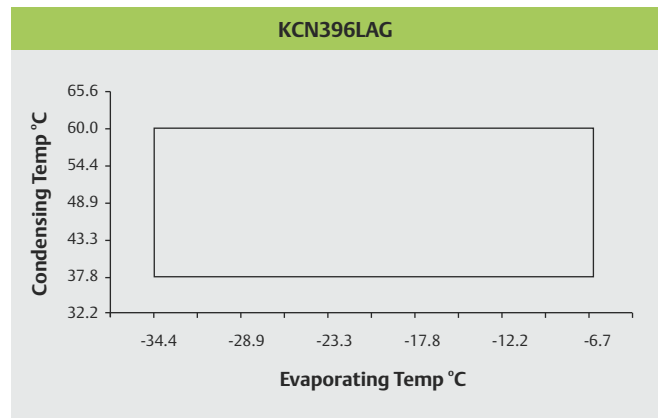
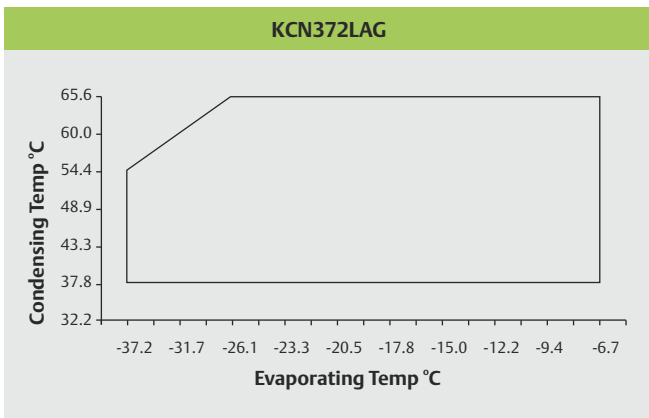

Low Temperature (R404A)

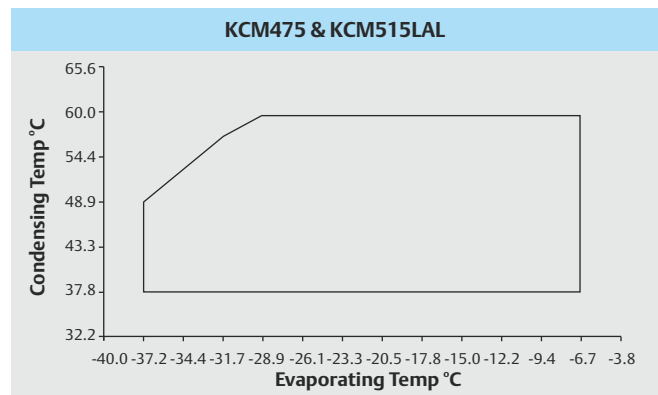
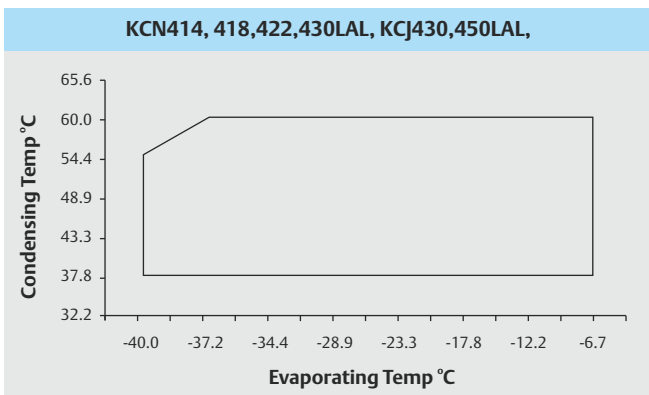

Operating Envelopes

High Temperature (R22)

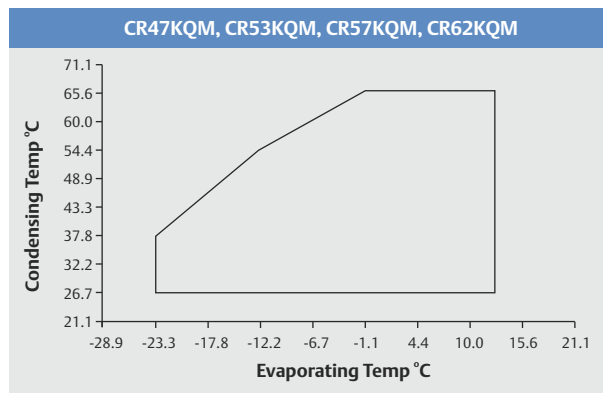
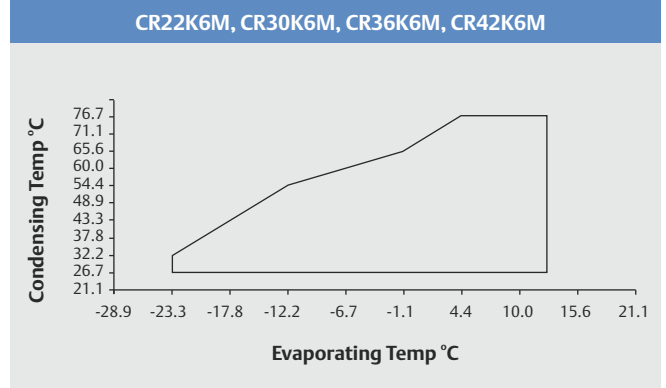
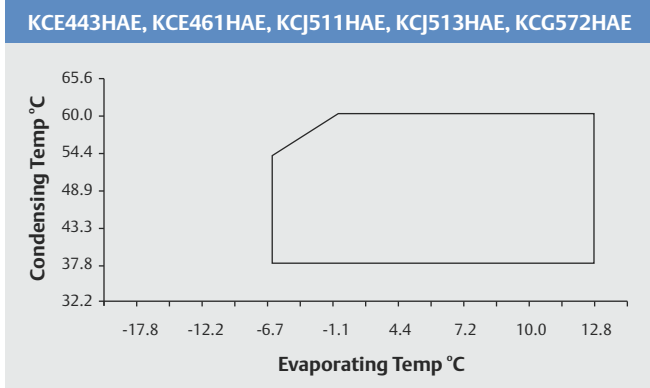

High Temperature (R134a)

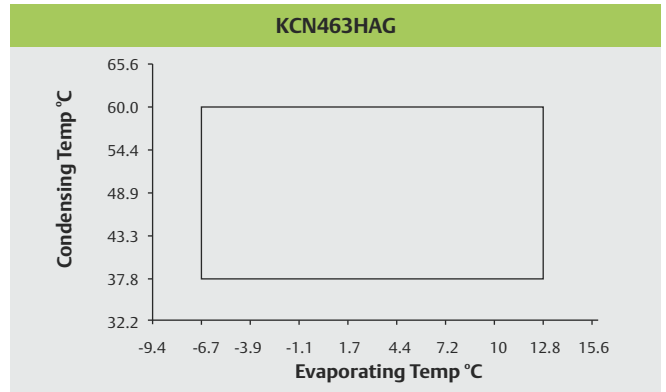
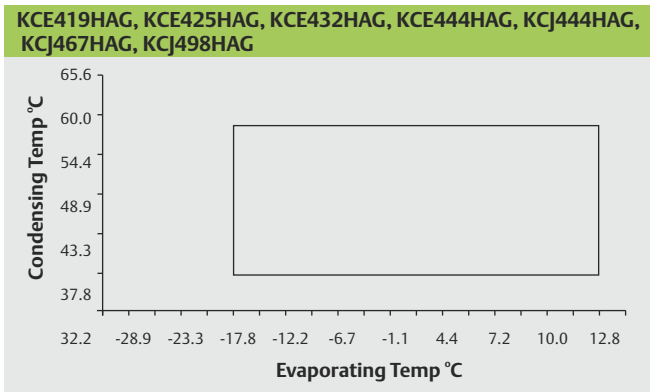

High Temperature (R134a)

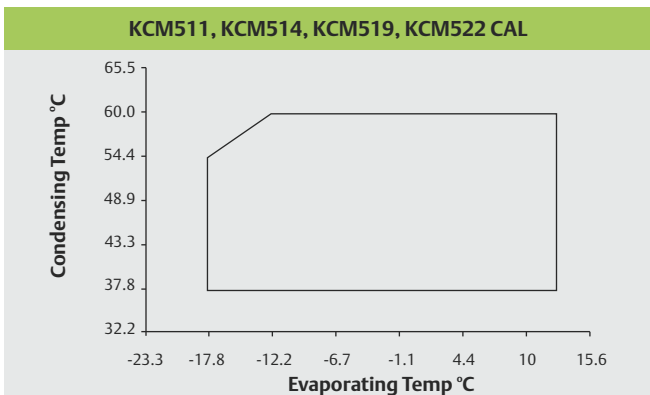

Medium Temperature (R134a)

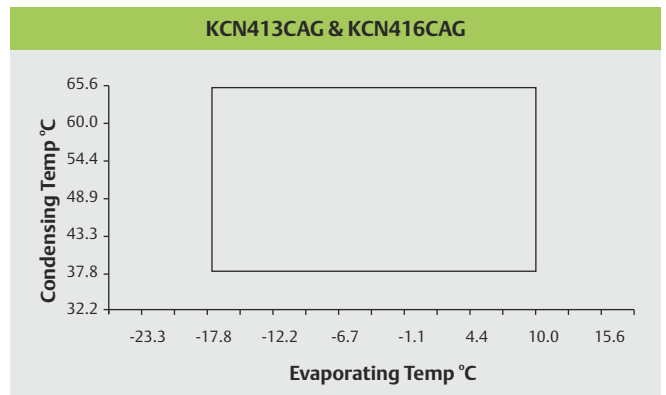

Standard BoM Data

Model	Standard*		Circuit	Suction	Mounting Option	
	Domestic	Export				
KCE419HAG	V130H	V131H	RSIR	Tube	"Dual Mounting4.00 x 6.50 & 2.75 x 6.69"	
KCE425HAG	V230H	V231H	CSIR	Tube		
KCE432HAG	S230H	S231H	CSIR	Tube		
KCE443HAE	B330H	B331H, V331H	CSCR	Tube		
KCE444HAG	B332H, S330H	V331H, S331H	CSCR	Tube		
	-	F231H, P231H	CSIR	Tube		
	S430H	-	PSC	Tube		
KCE461HAE	V470H	-	PSC	Tube		
KCE461HAE	-	V371H	CSCR	Tube		
KCN372LAG	B130H	B131H	RSIR	Tube		"Dual Mounting4.00 x 6.50 & 2.75 x 6.69"
	B230H	B231H	CSIR	Tube		
KCN396LAG	B230H	B231H	CSIR	Tube		
KCN411LAG	B230H	B231H	CSIR	Tube		
KCN413CAG	C230H	-	CSIR	Tube		
	V830H	V831H	CSCR	Tube		
KCN414LAL	B230H	B231H	CSIR	Tube		
KCN415LAG	B332H	B331H	CSCR	Tube		
KCN416CAG	V830H	V831H	CSCR	Tube		
KCN418LAL	B330H	B331H	CSCR	Tube		
KCN422LAL	B330H	B331H	CSCR	Tube		
KCN430LAL	B330H	B331H	CSCR	Tube		
KCN463HAG	U330H, U332H	U331H	CSCR	Tube		
KCJ412LAG	B220H	B221H	CSIR	Tube	4.80 x 8.00	
KCJ422CAL	B220H	B221H	CSIR	Tube		
	B222H	B223H	CSIR	Spud		
KCJ423LAG	C320H	C321H	CSCR	Tube		
KCJ430LAL	B320H	B321H	CSCR	Tube		
	B322H	B323H	CSCR	Spud		
KCJ438CAL	B220H	B221H	CSIR	Tube		
KCJ438CAL	B222H	B223H	CSIR	Tube		
KCJ444HAG	B220H	B221H	CSIR	Tube		
KCJ450LAL	B320H	B321H	CSCR	Tube		
	B322H	B323H	CSCR	Spud		
KCJ461CAL	B320H	B321H	CSCR	Tube		
	B322H	B323H	CSCR	Spud		
KCJ467HAG	T220H	T221H	CSIR	Tube		
	-	T222H	CSIR	Spud		
KCJ484CAL	B320H	B321H	CSCR	Tube		
	B322H	B323H	CSCR	Spud		
KCJ498HAG	S220H	S221H	CSIR	Tube		
	-	S222H	CSIR	Spud		
KCJ511HAE	-	U420H	PSC	Tube		
	-	U321H	CSCR	Tube		
	-	U322H	CSCR	Spud		
KCJ513HAE	S420H	-	PSC	Tube		
	-	S321H, S323H	CSCR	Tube		
	-	S322H	CSCR	Spud		
KCM475LAL	C310H	C311H	CSCR	Tube		"Square Mount7.50 x 7.50"
KCM475LAL	C313H	C312H	CSCR	Spud		
KCM511CAL	B310H	B311H	CSCR	Tube		
	B313H	B312H	CSCR	Spud		
	E510H	E511H	Three Phase	Tube		
	E513H	E512H	Three Phase	Spud		
KCM514CAL	B310H	B311H	CSCR	Tube		
	B314H	B312H	CSCR	Spud		
	E510H	E511H	Three Phase	Tube		
	E512H	E513H	Three Phase	Spud		
KCM515LAL	E510H	E511H	Three Phase	Tube		
	E513H	E512H	Three Phase	Spud		
KCM519CAL	B310H	B311H	CSCR	Tube		
	B313H	B312H	CSCR	Spud		
	E510H	E511H	Three Phase	Tube		
	E513H	E512H	Three Phase	Spud		
KCM522CAL	B310H	B311H	CSCR	Tube		
	B314H	B312H	CSCR	Spud		
	E510H	E511H	Three Phase	Tube		
	E514H	E512H	Three Phase	Spud		

* Contact Emerson Climate Technologies Representative for non standard BoM.

Standard BoM Data For CR Compressor

Model	Ordering BoM	Scope
CR22K6M-PF1	131	Standard 4 Leg Mounting, Suction & Discharge Tube, Mounting kit
CR30K6M-PF1	134	
CR22K6M-TFM	131	
CR30K6M-TFM		
CR36K6-PFZ	121	
CR42K6-PFZ		
CR36K6-TF6	101	
CR42K6-TF5	111	
CRXXKQM-TFD (47,53,57,62)	233DM	Standard 4 Leg Mounting, Suction & Discharge Spud, Crank Case Heater, Mounting kit

Dimensional Drawings

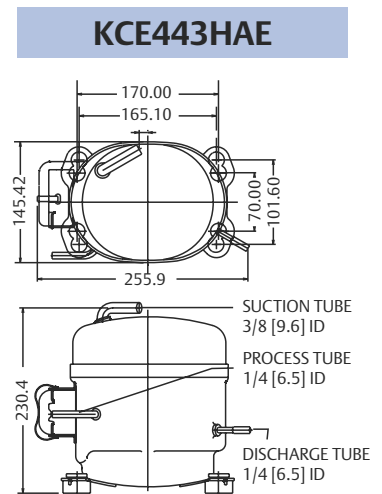
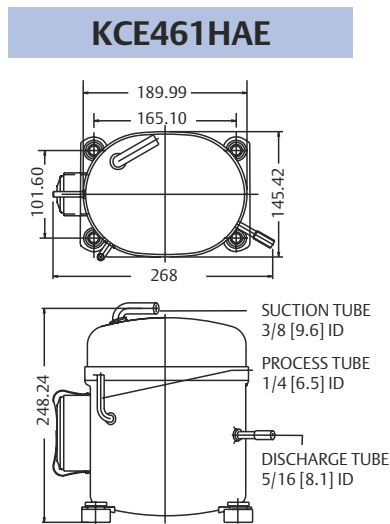
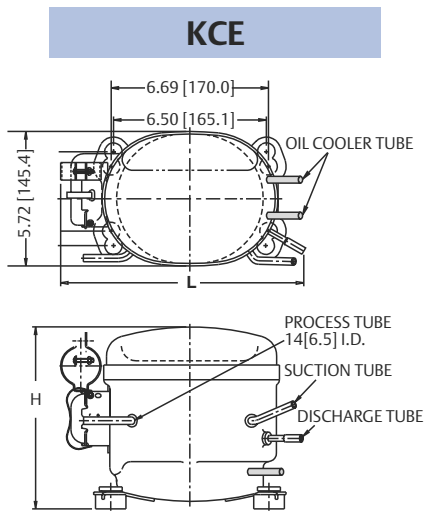

Model	Suction ID		Discharge ID		L	H	Capacitor Mounting
	Inch	mm	Inch	mm			
KCE419HAG	1/4	6.5	1/4	6.5	253	196	NO
KCE425HAG	1/4	6.5	1/4	6.5	257	196	YES
KCE432HAG	5/16	8.0	1/4	6.5	257	212	YES
KCE444HAG	5/16	8.0	1/4	6.5	253	212	NO

KCN

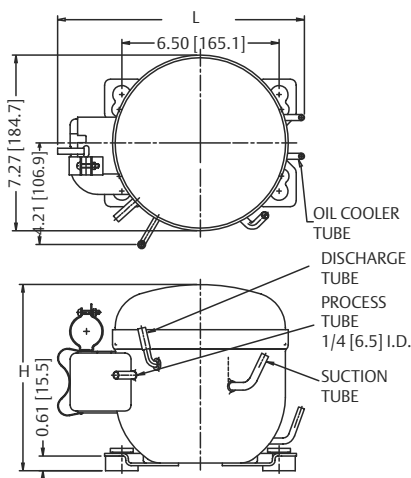

Model	Suction ID		Discharge ID		L	H	Oil Cooler Tube		Capacitor Mounting
	Inch	mm	Inch	mm			Inch	mm	
KCN372LAG	1/4	6.5	1/4	6.5	259	189	3/16	4.9	NO
KCN396LAG	1/4	6.5	1/4	6.5	259	196	3/16	4.9	YES
KCN411LAG	5/16	8.0	5/16	8.0	250	202	—	—	YES
KCN415LAG	5/16	8.0	5/16	8.0	250	202	—	—	YES
KCN463HAG	5/16	8.0	5/16	8.0	244	202	—	—	YES
KCN413CAG	1/4	6.5	1/4	6.5	244	189	—	—	YES
KCN416CAG	1/4	6.5	1/4	6.5	244	189	—	—	YES
KCN414LAL	5/16+	8.0	5/16	7.93	251	202	—	—	YES
KCN418LAL	5/16+	8.0	5/16	7.93	251	202	—	—	YES
KCN422LAL	5/16+	8.0	5/16	7.93	251	202	—	—	YES
KCN430LAL	5/16+	8.0	5/16	7.93	251	202	—	—	YES

Dimensional Drawings

KCJ430LAL

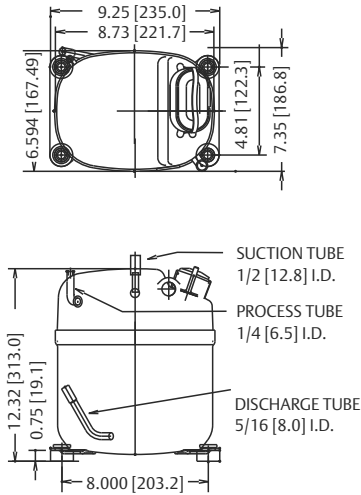

KCJ450LAL with Suction Tube

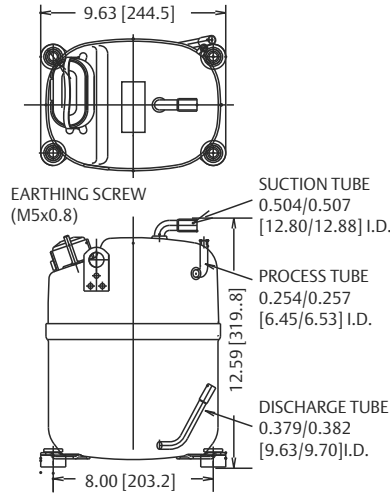

KCJ450LAL with Suction Spud

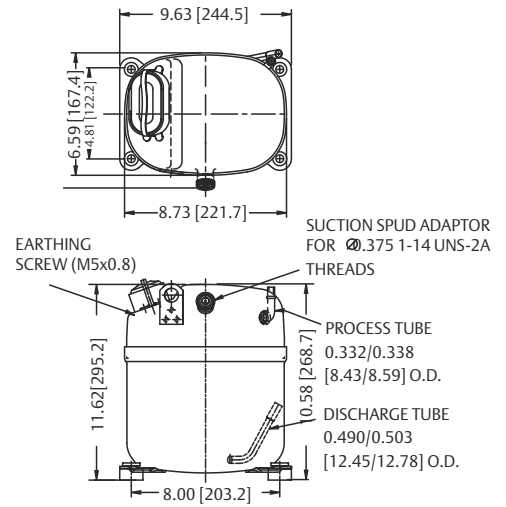

KCJ***CAL with Suction Spud

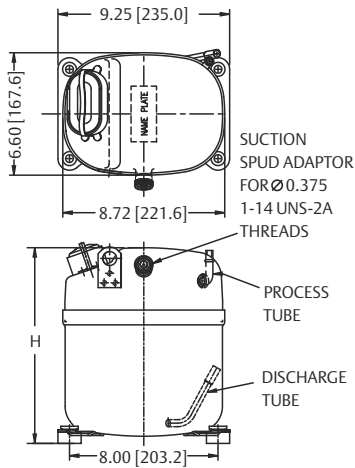

KCJ***CAL with Suction Tube

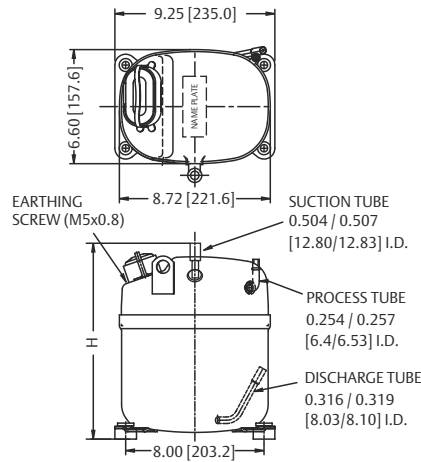

Model	With Suction Spud	With Suction Tube
	Height, (H) (mm)	
KCJ422CAL	267.9	290
KCJ438CAL	274.9	290
KCJ461CAL	286	308
KCJ484CAL	317.2	295.2

CR22K6M / CR30K6M

SQUARE MOUNT

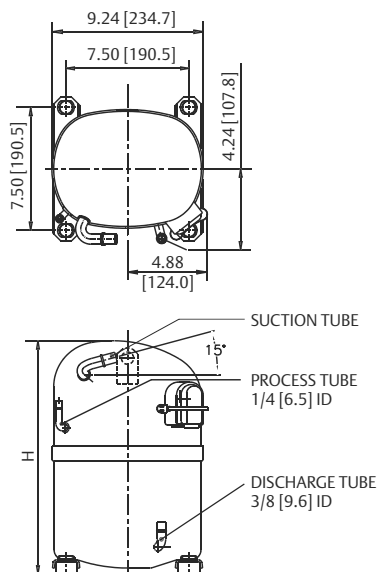

Model	Suction Tube		Height, (H)	
	inch	mm	inch	mm
CR22K6M	1/2	12.8	14.2	361
CR30K6M	5/8	15.9	14.9	381

Dimensional Drawings

CR36K6

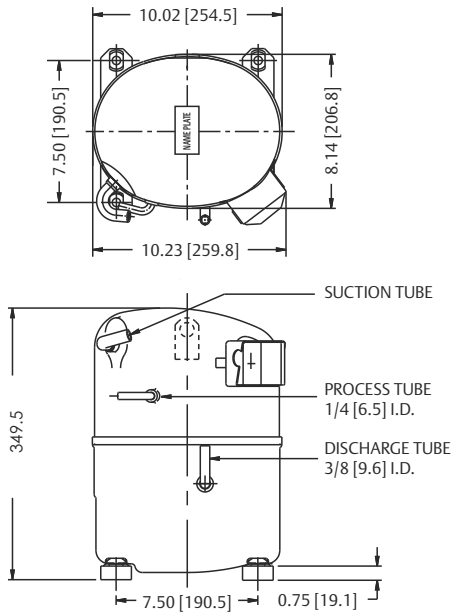

CR42K6

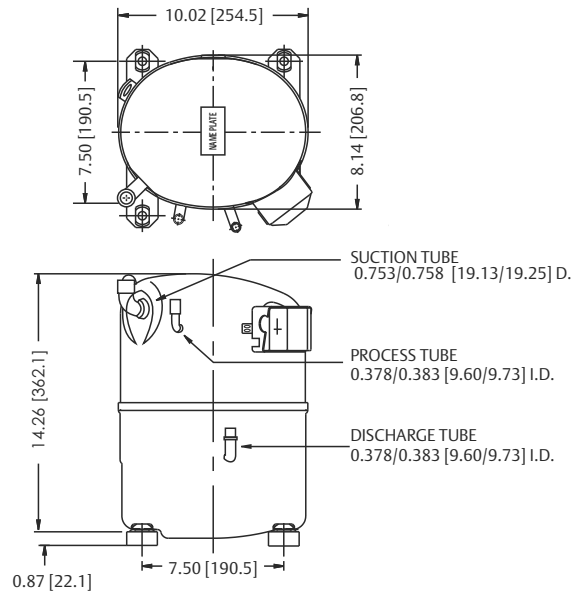

KCG572HAE

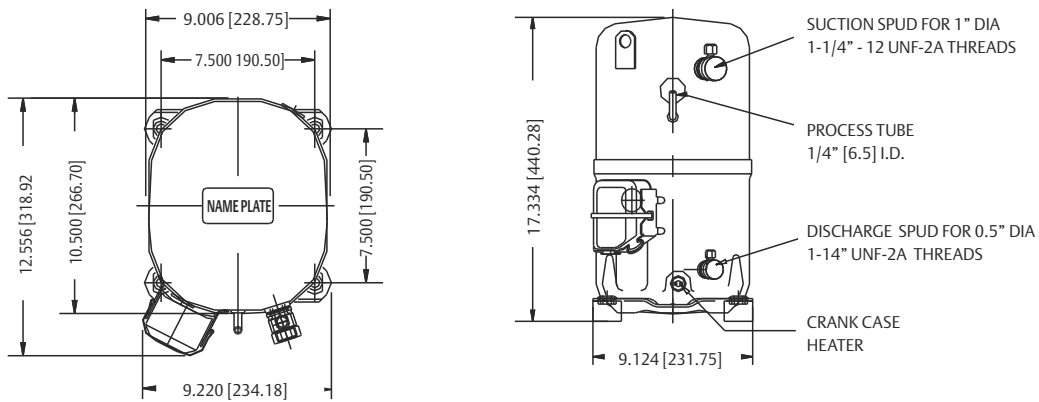

CR47, 53, 57, 62 KQM

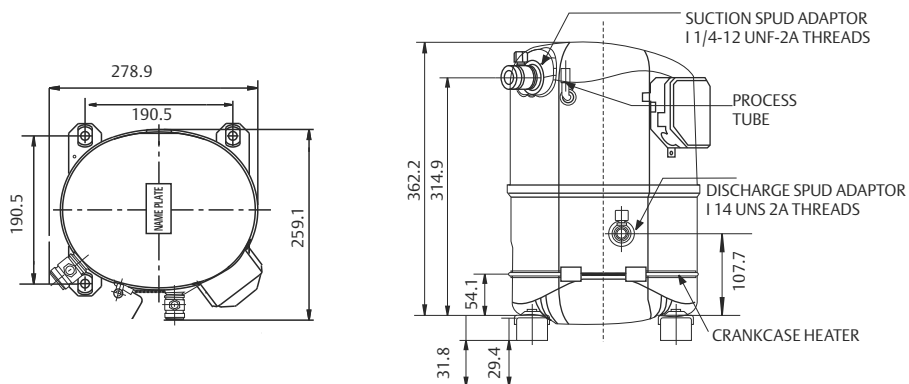

Dimensional Drawings

KCM475 LAL/511CAL/514CAL with Spud

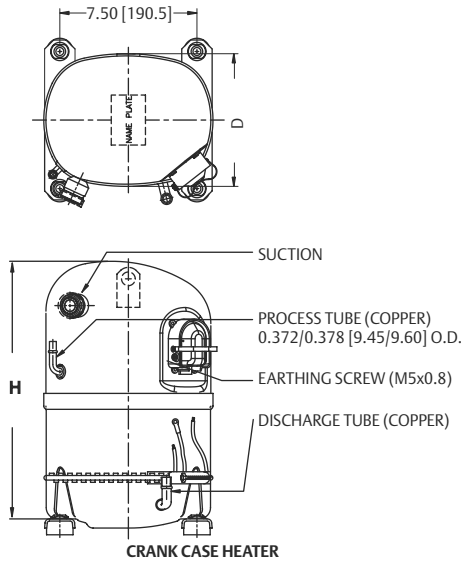

KCM475 LAL/511CAL/514CAL with Suction Tube

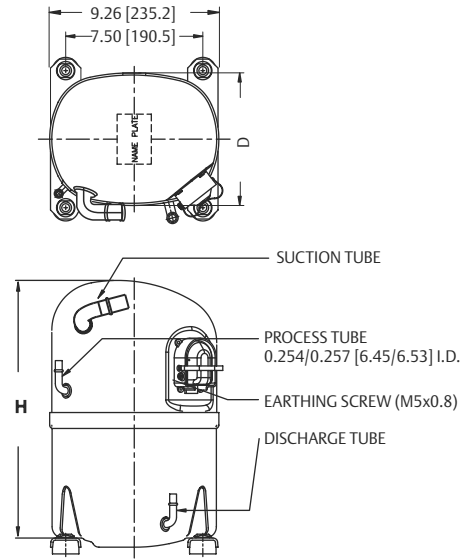

KCM515LAL/519CAL/522CAL with Spud

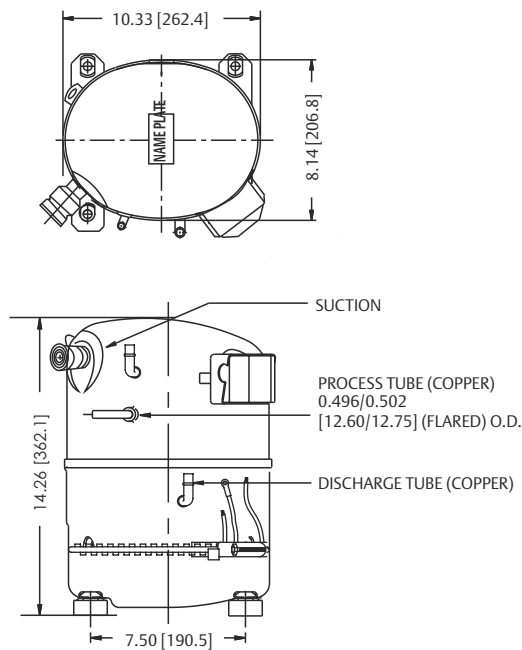

KCM515LAL/522CAL with Suction Tube

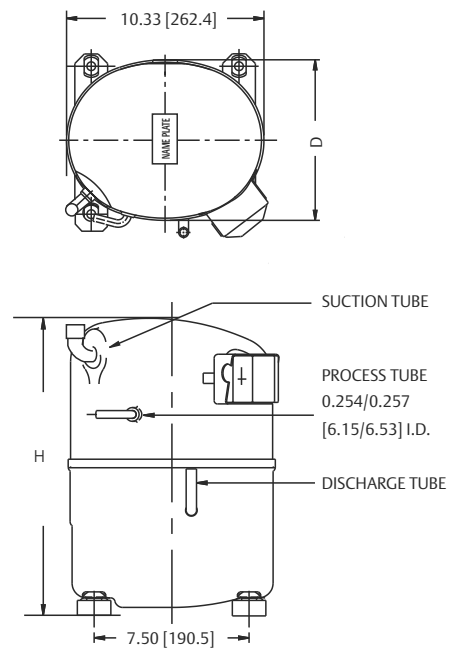

KCM519CAL

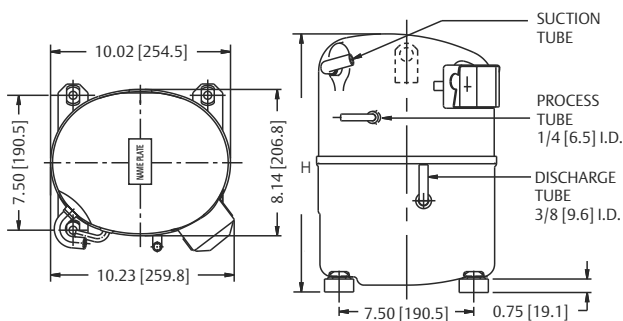

Model	Suction Spud	Suction Tube	Discharge Tube	Height, H (mm)	Depth, D (mm)
KCM475LAL	Ø0.625 11/4-12UNF	7/8"	3/8"	358	190.5
KCM511CAL	1.1/412UNF-2A Threads	5/8"	3/8"	361	184.4
KCM514CAL	1.1/412UNF-2A Threads	7/8"	3/8"	367	184.4
KCM515LAL	Ø0.625 11/4-12UNF-2A Rolled Threads	7/8"	3/8"	380	211.4
KCM519CAL	Ø0.625 11/4-12UNF Rolled Threads	7/8"	3/8"	371.5	206.8
KCM522CAL	Ø0.625 11/4-12UNF Rolled Threads	7/8"	3/8"	384.2	206.8

Wiring Diagrams

PERMANENT SPLIT CAPACITOR (PSC)

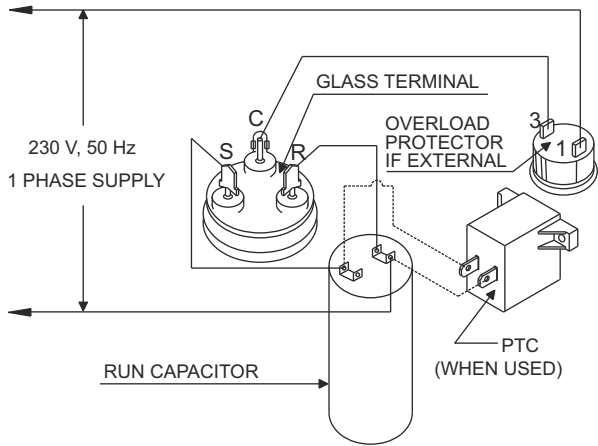

Fig. 1

CAPACITOR START INDUCTION RUN (CSIR) WITH PLUG-IN START RELAY

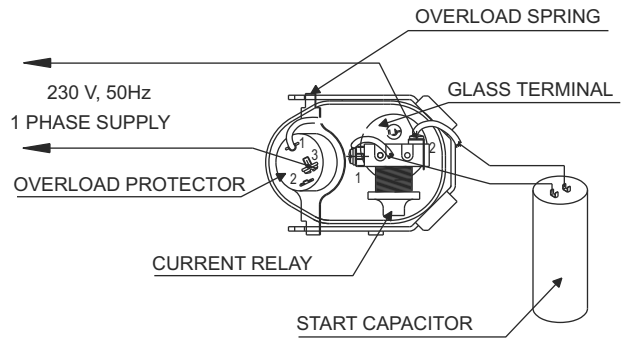

Fig. 2

RESISTANCE START INDUCTION RUN (RSIR) WITH PLUG-IN START RELAY

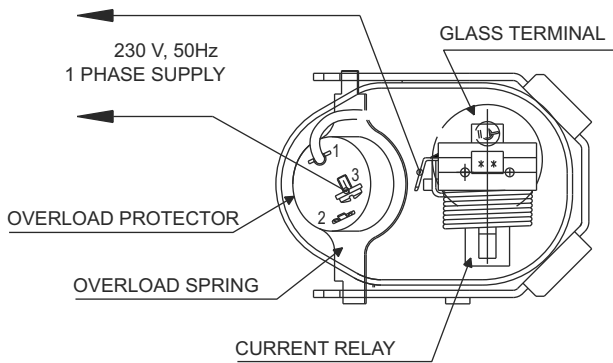

Fig. 3

CAPACITOR START CAPACITOR RUN (CSCR)

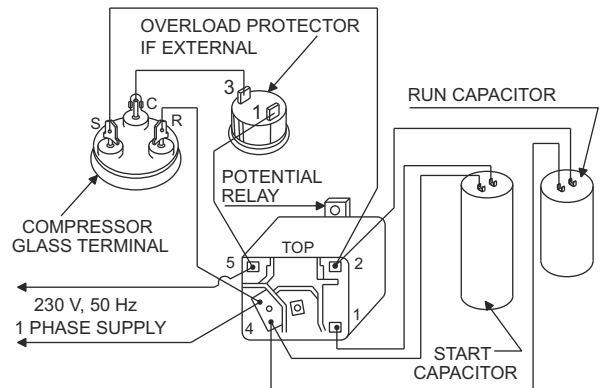

Fig. 4

CAPACITOR START INDUCTION RUN (CSIR)

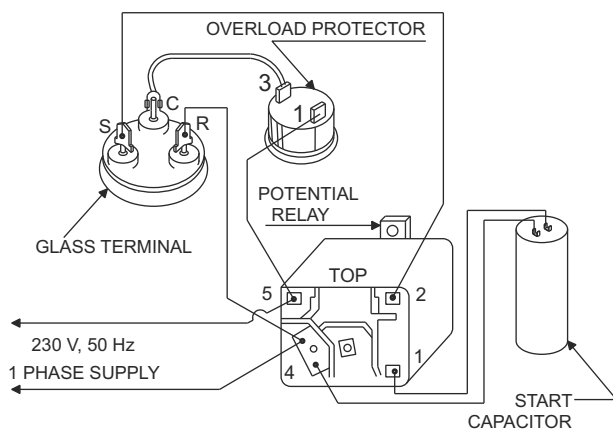

Fig. 5

CAPACITOR START INDUCTION RUN (CSIR) WITH CURRENT RELAY

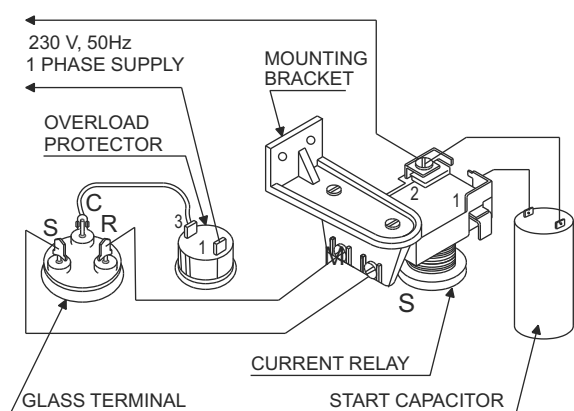

Fig. 6

Wiring Diagrams

CAPACITOR START CAPACITOR RUN (CSCR) WITH PTC

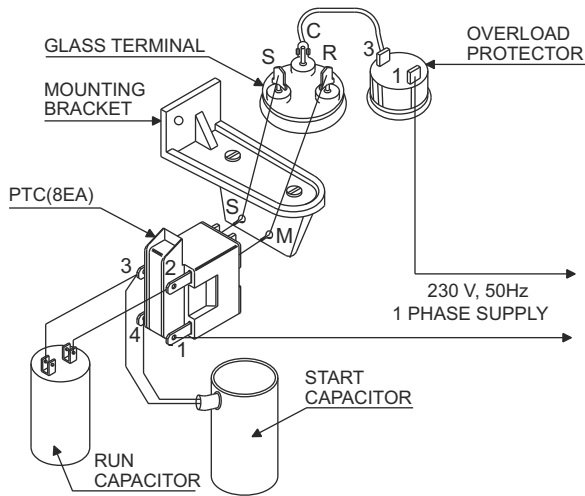

Fig. 7

CAPACITOR START CAPACITOR RUN (CSCR) WITH NTC

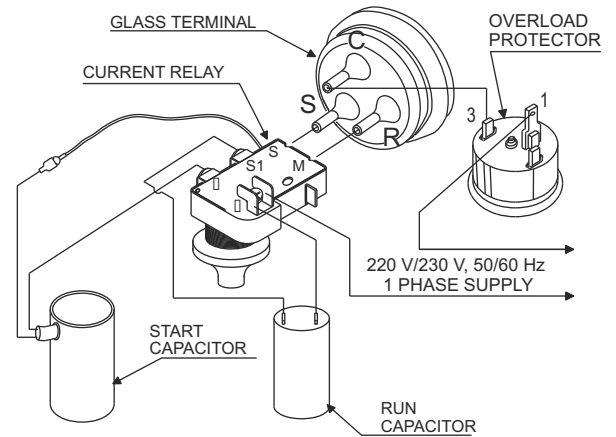

Fig. 8

Guidelines For Achieving Optimum Appliance Performance

Deep Freezer

- Evaporator circuit should be bottom to top
- Minimum 75mm PUF insulation
- Capillary to suction line heat exchanger of 6" improves the performance

Walk-in Cooler

- Proper heat load should be estimated for selecting number of systems.
- Adequate wall and floor insulation with ante room to be provided.
- Initial pull down time will range from 18 to 24 hrs.
- Hot gas defrost method should not be used.
- Use proper capacity strip heaters placed equidistant across the width of evaporator coil.

Softy Ice-cream Machine

- Pre-cooling of softy mix to 4°C should be achieved through separate refrigeration system.
- Compressor cycling should not exceed 6 cycles.

Ice Candy

- Use suction line accumulator of 3" dia x 8" height having oil return orifice.
- Evaporator feeding from bottom to top.
- Use stirrer in brine tank for brine circulation to achieve uniform brine temperature.
- Correct % mix of brine and water is important to achieve desired brine temperature.
- -20°C of brine temperature will ensure 20 minute batch time of hard candies.

Copeland Brand Products are used for several other applications. Above guidelines are apart from system design details. For details contact nearest Emerson Climate Technologies (India) Limited office.

Applications

Low Temperature

- Deep Freezer
- Refrigerator
- Ice Cube machine
- Walk-in Freezer
- Laboratory Appliance

Medium Temperature

- Bottle Cooler
- Visi Cooler
- Display Cabinet
- Pastry Cabinet
- Softy Ice Cream

High Temperature

- Water Cooler
- Oil Coolers / Panel Cooler
- Water Chiller
- Refrigerated Air Dryer
- Walk in Cooler
- Milk Cooler



Model Selection Guide *

Deep Freezer		
Hard Top (Ltr)	Glass Top (Ltr)	Model
300	200	KCN372LAG
400	300	KCN396LAG
450	300	KCN411LAG
450	300	KCJ412LAG
500	400	KCN415LAG
800	-	KCJ423LAG
1100	-	KCJ430LAL
1800	-	KCJ450LAL

Cold Room (+4° C Room Temperature)			
Room Size (cft)	R22	R134a	R404A
500	KCJ513HAE	KCM511CAL	KCJ484CAL
800	CR22K6M	KCM511CAL	KCM511CAL
1200	CR30K6M	KCM514CAL	KCM514CAL
1600	CR30K6M	KCM519CAL	KCM514CAL
2000	CR36K6	KCM522CAL	KCM519CAL
2500	CR42K6	-	KCM522CAL
3000	CR53KQM	-	-
5000	CR62KQM	-	-

Water Cooler		
Capacity (Ltr/Hr)	R22	R134a
20	-	KCE419HAG
40	-	KCE444HAG/ KCJ444HAG
60	KCE461HAE	KCN463HAG/ KCJ467HAG
100	KCJ511HAE	KCJ498HAG
150	KCJ513HAE	KCM511CAL
200	CR22K6M	KCM514CAL
300	CR30K6M	KCM522CAL

* These are preliminary guidelines. The actual compressor selection may differ from the guidelines. Please check the system details before selecting compressor model.



Water Chiller			
Flow Rate (Ltr/Hr)	R22	R134a	R404A
600	KCJ513HAE	KCM514CAL	KCJ484CAL
800	CR22K6M	KCM519CAL	KCM511CAL
1000	CR30K6M	KCM522CAL	KCM514CAL
1400	CR36K6	-	KCM519CAL
1600	CR42K6	-	KCM522CAL
2000	CR53KQM	-	-
2400	CR62KQM	-	-
2800	KCG572HAE	-	-

Water inlet temperature : 10° C
Water outlet temperature: 5° C



Bottle Cooler		
Capacity(Ltr)	R22	R134a
100-120	-	KCE419HAG
150-200	-	KCE425HAG/ KCN413CAG
220-250	-	KCE432HAG/KCN416CAG
260-350	KCE443HAE	KCE444HAG/KCJ444HAG
350-500	KCE461HAE	KCN463HAG/KCJ467HAG
600-800	KCJ511HAE	KCJ498HAG



Visicooler	
Case	Model
2 (110 ltr)	KCE419HAG
4 (150 ltr)	KCE425HAG/ KCN413CAG
7 (250 ltr)	KCE432HAG/KCN416CAG
9 (400 ltr)	KCE444HAG/KCJ444HAG
12(650 ltr)	KCN463HAG



Softy Machine	
Capacity (Ltr)	R404A
15	KCM511CAL
20	KCM514CAL
30	KCM519CAL
40	KCM522CAL

System Practice Guide

System Cleanliness

- It is absolutely necessary that all impurities / contamination like moisture, burr, cleaning agent and chemicals are removed from the system before operation in order to avoid compressor failures.
- All system components have to be de-hydrated and should be Nitrogen charged till they are taken for assembly. Use bright annealed refrigeration grade Copper tubes.
- Use Try-chloro Ethylene for flushing followed by dry air or Nitrogen to remove the trace of Try-chloro Ethylene.

Brazing

- While brazing all the joints purge low pressure Nitrogen through the tube. This will avoid internal oxidation and formation of contamination. Use adequate amount of flux while brazing.
- The joints have to be free from oil and grease before brazing. For Copper to Copper joints use phosphorous Copper as brazing alloy and Copper - Silver for Copper to Steel joints. Oxy Acetylene is best suited for brazing.

Leak Testing

- The system has to be adequately pressurized with dry air or Nitrogen.
- Use of electronic leak detectors is the best way to detect leaks.
- Conventional methods of checking the leaks can also be used.
- Do not pressurize the system with air and R134a.

Evacuation

Effective evacuation of the system ensures removal of moisture. For achieving desired vacuum level of 200 microns:

- Pull vacuum from both sides
- Heat the system with bulbs or infra red lamps
- Use Copper tubes to connect the vacuum pump and the system
- The connecting Copper tubes have to be short in length and bigger in diameter
- Use adequately sized two stage rotary vacuum pump having anti-suckback provision
- Use electronic vacuum gauge to measure the vacuum level
- Never use a hermetic compressor for evacuation. It is not meant for evacuation and cannot achieve desired vacuum level

Refrigerant Charging

- Quality and quantity of refrigerant immensely influences the performance and reliability of any refrigeration system.
- Refrigerant should be procured from genuine source. Use digital weigh balance during refrigerant charging.
- Maintain a separate set of hoses, tubes, valves for different refrigerants. Do not use anti-choke as it damages the compressor.
- Use pressure temperature chart of refrigerant for achieving optimum system performance.

Compressor Mounting

- Torque the nut adequately and ensure that the washer / bolt head rest on the sleeve and not on the rubber grommet.
- The suction and discharge piping should be properly looped to avoid vibrations and refrigerant leakages. The compressor should not be held rigidly by any means.
- These compressors are not suitable for mobile applications.

Electricals

- Always check the voltage across C & R terminals. Voltage at this point should fall within the prescribed operating voltage range. If the supply voltage conditions are poor, use appropriately sized voltage stabilizer with low, high voltage cutout and On-delay timer.
- Always use genuine electrical accessories supplied by Emerson Climate Technologies.
- Earthing the appliance is necessary from the safety stand point.
- All electrical joints have to be firm and properly insulated.

Attending The Field Complaints

- Verify the field complaint based on facts and observations made through use of proper tools and equipment. Rule out all the possibilities before replacing the compressor. Analyze the compressor independently for its proper functioning.
- Removing of compressor from the system without understanding the root cause will lead to another compressor failure.

Contact us at

Sales Office

Ahmedabad
Emerson Climate Technologies (India) Ltd.
54, Shivam Estate, S. G. Highway, Sarkhej,
AHMEDABAD - 382 210
Gujarat, India
Tel: (91-79) 6943 1993

Chennai
Emerson Climate Technologies (India) Ltd.
New No.10, Postal Colony II street
West Mambalam
Chennai 600 033
Tamil Nadu, India
Tel : (91-44) 2371 8771/8772/8773
Fax : (91-44) 2371 8979

Faridabad
Emerson Climate Technologies (India) Ltd.
3B-3B.P., NIT
Faridabad 120 001
Haryana, India
Tel : (91-129) 2414581 , 2431037

New Delhi
Emerson Climate Technologies (India) Ltd.
56, Rama Road Industrial Area
Nr. Mahindra Showroom
New Delhi 110 015 India
Tel: (91-11) 2511 1861/1862/1863/1864
Fax: (91-11) 2545 7748

Registered Head Office

Emerson Climate Technologies (India) Limited

Plot No. 23, Rajiv Gandhi Infotech Park, Phase - II, Hinjewadi, Pune - 411 057
Tel: (91-20) 4200 2000, Fax: (91-20) 4200 2099

Plant

Atit Pali Road, Atit - 415 519, Maharashtra
Tel: (91-2162) 262068 / 262077, Fax: (91-2162) 262069

Technical Helpdesk: 1800 209 1700

E-mail: ClimateIndia@Emerson.com

Warehouse

Bengaluru
Emerson Climate Technologies (India) Ltd.
No.21, K. H. Road
Bengaluru 560 027
Karnataka, India
Tel : (91-80) 2222 0327
Fax : (91-80) 2227 6280

Pune
Emerson Climate Technologies (India) Ltd.
Newaskar Warehouse Corporation,
745/1 (746/1 Old), Near Lexicon
International School, Pune - Nagar Road, Wagholi,
Pune 412207
Maharashtra, India
Tel: (91-20) 64730217

Chandigarh
Emerson Climate Technologies (India) Ltd.
177, Industrial Area, Phase II,
Nr. Sree Gujarati Seva Mandal
Chandigarh - 160 002 India
Tel : (91-172) 2653987

Lucknow
Emerson Climate Technologies (India) Ltd.
Sumiran Bhavan, B-1/56, Sector B,
Aliganj, Lucknow - 226 024
Uttar Pradesh, India
Tel : (91-522) 2371922

As we are constantly endeavoring to improve the performance of our models, the specifications mentioned here are subject to change from time to time. The Emerson logo is a trademark and a service mark of Emerson Electric Co.

ASIA10B030303412

Copeland[®]
brand products

EMERSON[™]
Climate Technologies

EMERSON. CONSIDER IT SOLVED.