



# ROTARY COMPRESSOR Catalogue



SIAM COMPRESSOR  
INDUSTRY CO., LTD.



**SIAM COMPRESSOR  
INDUSTRY CO., LTD.**



## Content

### Index

Profile	Company Profile	03
Compressor Info	Rotary Compressor Benefits and Advantages	04
R-410A	Specifications of KN/RN	07
	Specifications of PN	08
	Specifications of NN	09
	KN/RN/PN/NN Operation Standards and Limits	10
Inverter Comp.	Inverter Compressor Information	11
	Specifications of SVB/SNB/TNB	12
	SVB/SNB/TNB Operation Standards and Limits	13
R-134A	Specifications of RB	14
R-32	Specifications of KV/RV/PV	15
	KV/RV/PV Operation Standards and Limits	16
R-407C	Specifications of RE	17
	Specifications of PE/NE	18
	RE/PE/NE Operation Standards and Limits	19
R-22	Specifications of RH	20
	Specifications of PH	21
	Specifications of NH	22
	RH/PH/NH Operation Standards and Limits	23
Ultra Tropical	Specifications of Ultra Tropical R-410A	24
(R-410A, R-32, R-22)	Specifications of Ultra Tropical R-32/R-22	25
	Ultra Tropical Operation Standards and Limits	27



MITSUBISHI ELECTRIC (GUANGZHOU) COMPRESSOR CO., LTD.



MITSUBISHI ELECTRIC CORPORATION,  
SHIZUOKA WORKS (MELSHI)



SIAM COMPRESSOR INDUSTRY CO., LTD. (SCI)

# Company Profile

**Siam Compressor Industry Co., Ltd. (SCI)** is Thailand's first manufacturer of rotary compressor for room air conditioner. SCI was founded on May 25, 1990 as a subsidiary of Mitsubishi Electric Corporation of Japan, a world leader in compressor technology with over 70 years of experience. So successful was SCI in the first year of production that we were able to open a second plant only five years later, on December 16, 1995. Further milestones since then have been the inauguration of our research and development centre in 1998, the launching of a new ozone-friendly compressor that does not use HCFC coolant in 1999, the opening of a third plant on October 16, 2002 and recently, the opening of the forth plant in June 2012.

Since 2003, SCI has been producing Advanced Scroll Compressor utilizing Frame-Complaint Mechanism technology, thus saving energy and minimizing energy loss due to friction. SCI remains at the forefront of the global compressor industry in terms of technical progress, efficiency of production, the competence of our trained staff and our ongoing expansion.

In 2013, SCI received the Good Factory Awards for Factory Management in Japan, SCI has been performing many outstanding activities such as the development, the supply chain management, production process, and working system in factories to help strengthen management system. SCI was the first compressor manufacturer in Thailand to receive this honorable award.



# Rotary Compressor Benefits and Advantages

## Rotary Compressor Line-Up

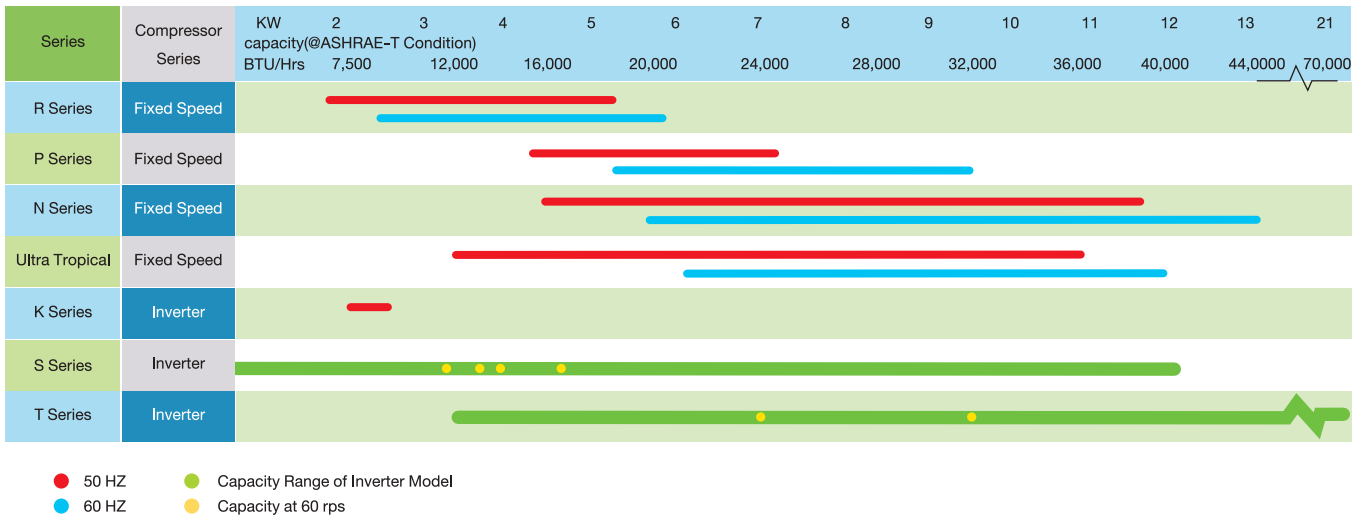

## SCI Rotary Compressor

Under Mitsubishi Electric Technology, SCI rotary compressors have a smoothly operating system, with a great performance and durability even in a tough environment zone, suitably match for variety of applications such as air-conditioning, heat pump, refrigerating showcase and ice making machine.

**Efficiency:** SCI has developed and designed full line-up range of superior performance compressor to serve variety of applications. This is because of SCI R&D technology advancement, modernized production process and high-graded material selection.

**Alternative Refrigerant:** Since SCI pays high respect to the nature and environment, SCI has developed new compressors for environmental friendly refrigerants, R-410A, R-32 and R-290 which all have low GWP and ODP rate to make sustainable world.

**Reliability:** SCI state-of-the-art facilities, with automatic line control and customized production technique, lead to very low defective rate and reliable product with less deviation performance. Quality control process of SCI including robot and experienced staff always assure every compressor in every production process before reaching the customers. This is a reason why Mitsubishi Electric stands for a high quality brand for more than 90 years.

**Durability:** SCI rotary compressors are verified by a life testing by SCI Research and Development Center that can guarantee great long term operation.

**Product Variety:** SCI rotary compressors are designed to customize to match different needs in each conditions of different applications such as refrigerants, operating temperature sizing, electrical supply and other special requirements.



### Testing Condition

**ASRE-T Testing Condition:** Evaporating Temp. 7.2°C (45°F), Return Gas Temp. 35°C (95°F), Condensing Temp. 54.4°C (130°F), Liquid Temp. 46°C (115°F), Ambient Temp. 35°C (95°F)

**ARI Testing Condition:** Evaporating Temp. 7.2°C (45°F), Return Gas Temp. 18.3°C (65°F), Condensing Temp. 54.4°C (130°F), Liquid Temp. 46°C (115°F), Ambient Temp. 35°C (95°F)

# Rotary Compressor

General Information SCI R-410A, R-134A, R-32, R-407C, R-22, Ultra Tropical

## Model Code Diagram

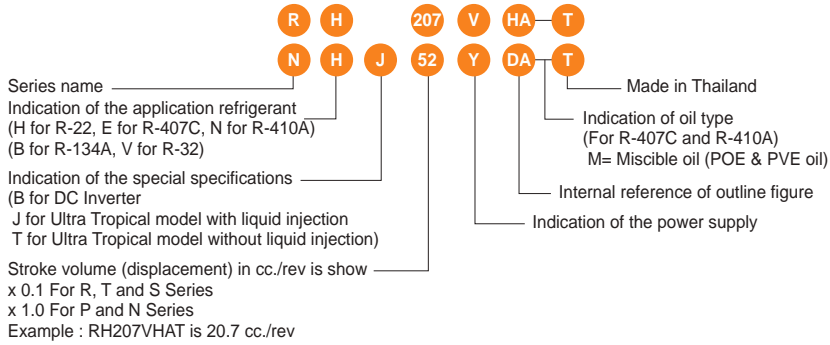

## Power Supply Symbol

Symbol	Phase	Rated Voltage(V)	Rated Frequency(Hz)	Note
N	1	208-230	60	-
V	1	220-240	50	-
W	1	115-120	60	A
C	1	200-220	50	A
H	1	265-277	60	A
T	3	200/200-230	50/60	B
Y	3	380-415/400(460)	50/60	B
F	3	Inverter	Variable	-

Note : A = Available in some model of R series  
B = Available in some model of N series

## Wiring Diagram

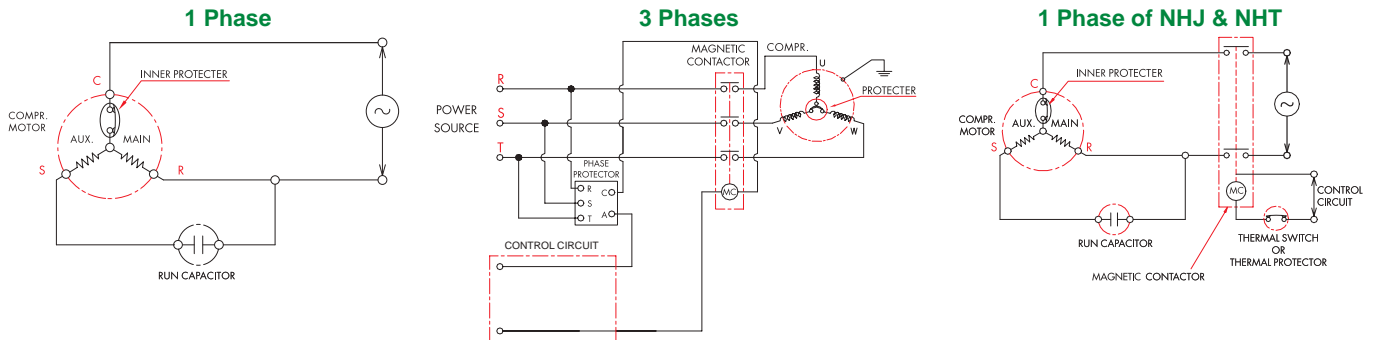

## Mounting Assembly

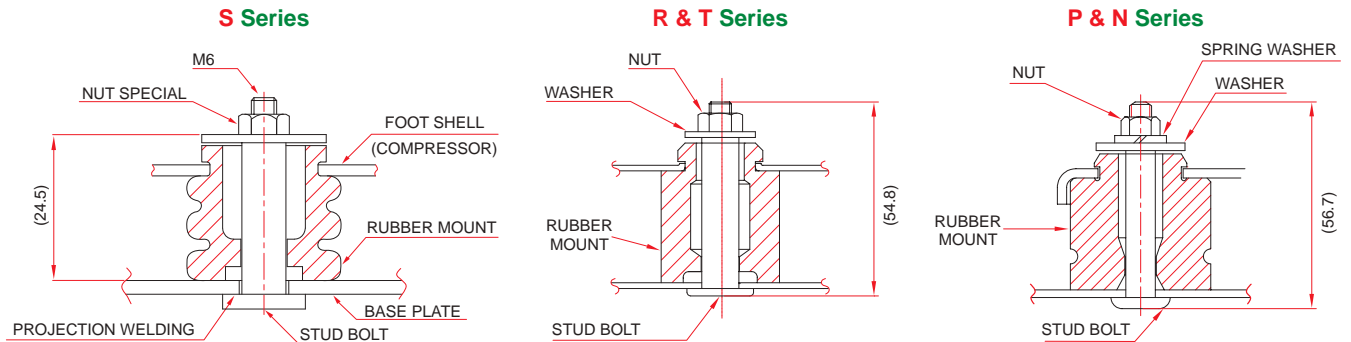

## Compressor Accessories

### R & T & PHT & PNT



- 1 Terminal Cover    2 Packing    3 Flange Nut
- 4 Rubber Washer    5 Rubber Mount

### K series



- 1 Terminal Cover    2 Packing    3 Flange Nut
- 4 Rubber Washer    5 Rubber Mount

### PH & PE & NH & NE & NN



- 1 Terminal Cover    2 Gasket
- 3 Clip    4 Rubber Mount

### S Series



- 1 Terminal Cover    2 Packing    3 Flange Nut
- 4 Rubber Washer    5 Rubber Mount

### TNB Series



- 1 Terminal Cover    2 Packing    3 Flange Nut
- 4 Rubber Washer    5 Rubber Mount

## Optional Accessories Thermoacoustic Shell

### Selection Table for Thermoacoustic Shell

Series	Code no.	Group no.	Detail
S	SC00G241	G1	For SNB
T	SC00G242	G1	For TNB

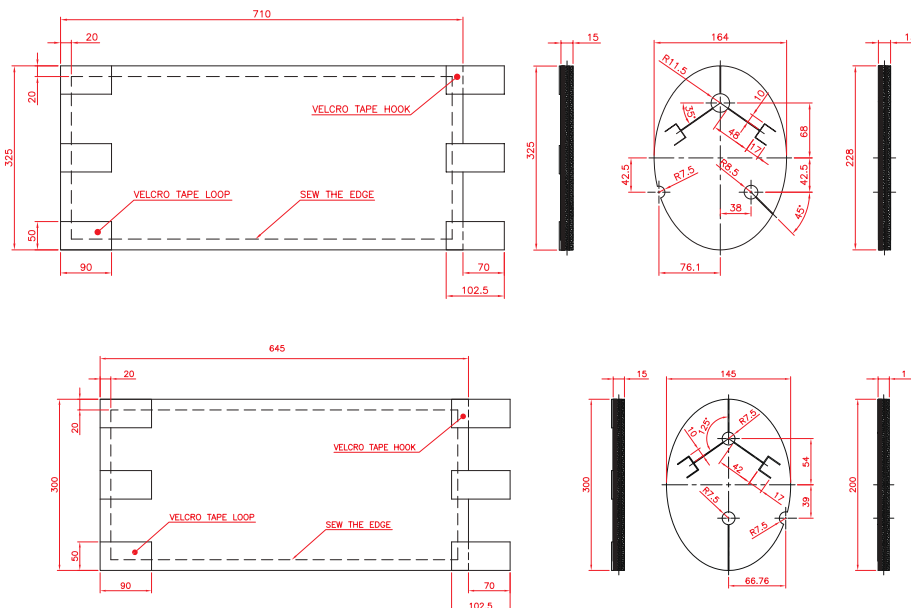

### T Series



### S Series



# Specifications of KN/RN Model

Models	Capacity			Input		Nominal Output		COP. (W/W)	EER. (Btu/hr*W)	Run Cap. (µF/VAC)	Weight (kgs.)	Oil Q'ty (cc.)
	W	Kcal/hr	Btu/hr	Watt	Amps	HP	KW.					

## High EER Models

### a) Electrical 50 Hz : 220 - 240 Volt : 1 Phase

KN092V--MT	2,295	1,974	7,831	840	3.90	0.94	0.70	2.73	9.32	25 / 370	9.9	300
KN096V--MT	2,320	1,995	7,916	820	3.70	0.87	0.65	2.83	9.65	25 / 370	9.9	300
KN104VABMT	2,500	2,150	8,530	880	4.10	0.94	0.70	2.84	9.69	25 / 370	10.2	300
RN092VHSM	2,240	1,926	7,643	770	3.60	0.80	0.60	2.91	9.93	20 / 370	13.8	300
RN096VHSM	2,340	2,012	7,984	805	3.70	0.87	0.65	2.91	9.92	20 / 370	13.8	300
RN099VHSM	2,390	2,055	8,155	820	3.80	0.87	0.65	2.91	9.94	25 / 370	13.8	300
RN104VHSM	2,510	2,158	8,564	865	4.00	0.94	0.70	2.90	9.90	25 / 370	13.8	300
RN110VHSM	2,680	2,304	9,144	920	4.20	1.01	0.75	2.91	9.94	25 / 370	13.8	300
RN117VHSM	2,850	2,450	9,724	975	4.40	1.07	0.80	2.92	9.97	25 / 370	13.8	300
RN125VHSM	3,050	2,623	10,407	1,050	4.90	1.07	0.80	2.90	9.91	25 / 370	13.8	300
RN130VHSM	3,160	2,717	10,782	1,080	5.00	1.14	0.85	2.93	9.98	30 / 370	15.9	520
RN135VHSM	3,220	2,768	10,987	1,120	5.20	1.21	0.90	2.88	9.81	35 / 370	13.5	300
RN140VHNMT	3,450	2,967	11,771	1,160	4.00	1.21	0.90	2.97	10.15	30 / 370	15.2	520
RN145VHSM	3,570	3,070	12,181	1,220	5.80	1.34	1.00	2.93	9.98	30 / 370	15.8	520
RN154VHSM	3,820	3,285	13,034	1,320	6.20	1.48	1.10	2.89	9.87	30 / 400	15.8	520
RN165VHSM	4,070	3,499	13,887	1,410	6.60	1.48	1.10	2.89	9.85	30 / 400	15.8	520
RN174VHQMT	4,170	3,586	14,228	1,390	5.00	1.61	1.20	3.00	10.24	40 / 370	15.3	520
RN189VHQMT	4,400	3,784	15,013	1,550	6.00	1.74	1.30	2.84	9.69	40 / 370	15.3	520
RN196VHQMT	4,800	4,128	16,378	1,580	5.00	1.74	1.30	3.04	10.37	40 / 370	15.3	520
RN207VHQMT	5,190	4,462	17,708	1,700	8.10	1.88	1.40	3.05	10.42	45 / 420	15.3	520
RN220VHSM	5,480	4,712	18,698	1,920	8.80	2.15	1.60	2.85	9.74	45 / 370	16.5	520

### b) Electrical 60 Hz : 115 - 120 Volt : 1 Phase

RN092WHDMT	2,856	2,456	9,745	959	8.45	0.87	0.65	2.98	10.16	70 / 220	13.8	300
RN099WHDMT	2,960	2,545	10,100	1,020	9.11	0.94	0.70	2.90	9.90	75 / 220	13.7	300
RN104WHDMT	3,119	2,682	10,642	1,065	9.40	0.94	0.70	2.93	9.99	75 / 220	13.8	300
RN110WHDMT	3,280	2,820	11,191	1,113	9.84	0.94	0.70	2.95	10.06	75 / 220	13.7	300
RN125WHDMT	3,770	3,241	12,863	1,280	11.42	1.07	0.80	2.95	10.05	80 / 220	13.7	300
RN140WHDMT	4,258	3,662	14,528	1,461	12.90	1.21	0.90	2.91	12.90	85 / 220	15.8	520

### c) Electrical 60 Hz : 208 - 230 Volt : 1 Phase

RN092NHTMT	2,870	2,468	9,792	910	4.35	1.07	0.80	3.15	10.76	30 / 370	15.9	400
RN096NHTMT	3,010	2,588	10,270	960	4.64	1.14	0.85	3.10	10.59	30 / 370	15.9	400
RN110NHTMT	3,400	2,924	11,601	1,090	5.07	1.29	0.96	3.12	10.65	30 / 370	15.9	400
RN117NHTMT	3,680	3,165	12,556	1,160	5.40	1.37	1.02	3.17	10.82	30 / 370	15.9	400
RN125NHTMT	3,890	3,345	13,273	1,230	5.70	1.43	1.07	3.16	10.79	30 / 370	15.9	400
RN135NHTMT	4,270	3,672	14,569	1,320	6.13	1.57	1.17	3.23	11.04	35 / 400	16.0	400
RN140NHTMT	4,440	3,818	15,149	1,370	6.41	1.62	1.21	3.24	11.06	35 / 400	16.0	520
RN145NHTMT	4,590	3,947	15,661	1,410	6.55	1.68	1.25	3.26	11.11	35 / 370	16.0	520
RN154NHTMT	4,900	4,214	16,719	1,520	7.25	1.81	1.35	3.22	11.00	35 / 400	16.0	520
RN165NHTMT	5,220	4,489	17,811	1,640	7.88	1.90	1.42	3.18	10.86	35 / 400	16.0	520
RN174NHTMT	5,480	4,712	18,698	1,750	8.22	2.00	1.49	3.20	10.93	35 / 370	16.0	520
RN196NHTMT	6,170	5,306	21,052	1,940	9.17	2.23	1.66	3.18	10.85	45 / 400	16.0	520
RN220NHTMT	6,980	6,001	23,645	2,200	10.35	2.49	1.86	3.15	10.75	45 / 370	16.0	520

- Note : 1. Testing condition ASRE-T, for V code at 1 Phase 220 Volt 50 Hz, for N code at 1 Phase 220 Volt 60 Hz, for W code at 1 Phase 115 Volt 60 Hz  
 2. All figures indicated are nominal value, for detailed specification, please contact sales representative  
 3. Oil type is FV505

	Dimension (mm.)					
	A	B	C	D	E	F
KN	244.1	249.5	93.0	64.5	12	8
RN135VHVMT	213.1	243.8	101.0	60.5	9.6	9.6
RN092-125VHSM						
RN092-125WHDMT						
RN092-125NHDMT						
RN135-140VHNMT	257.5	260.5	110.5	74.0	12.7	9.6
RN140WHDMT						
RN130-220VHSM						
RN092-220NHTMT						
RN174-207VHQMT	256.2	287.5	110.5	78.0	12.7	9.6

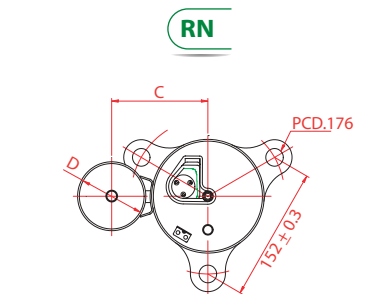
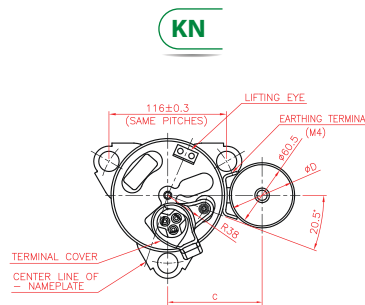

# Specifications of PN Model

Models	Capacity			Input		Nominal Output		COP. (W/W)	EER. (Btu/hr*w)	Run Cap. (µF/VAC)	Weight (kgs.)	Oil Q'ty (cc.)
	W	Kcal/hr	Btu/hr	Watt	Amps	HP	KW.					
<b>High EER Models</b>												
a) Electrical 50 Hz : 220 - 240 Volt : 1 Phase												
PN23VAAMT	5,860	5,038	19,994	1,990	9.40	2.28	1.70	2.94	10.05	55 / 400	23.7	900
PN25VAAMT	6,360	5,468	21,700	2,165	10.00	2.41	1.80	2.94	10.02	60 / 450	23.7	900
PN27VAAMT	6,800	5,846	23,202	2,290	10.70	2.55	1.90	2.97	10.13	65 / 420	23.7	900
PN31VBBMT	7,900	6,794	26,955	2,660	12.30	2.95	2.20	2.97	10.13	65 / 420	24.0	900
PN33VABMT	8,490	7,301	28,968	2,920	13.30	3.08	2.30	2.91	9.92	65 / 420	24.5	900
b) Electrical 60 Hz : 208 - 230 Volt : 1 Phase												
PN23NABMT	7,165	6,160	24,447	2,440	11.30	2.01	1.50	2.94	10.02	40 / 400	23.7	900
PN25NABMT	7,660	6,586	26,136	2,645	12.30	2.15	1.60	2.90	9.88	40 / 400	23.7	900
PN27NABMT	8,320	7,153	28,388	2,810	13.00	2.28	1.70	2.96	10.10	45 / 400	23.7	900
c) Electrical 50 Hz : 380 - 415 Volt : 3 Phases												
PN31YBAMT	8,050	6,923	27,467	2,650	4.70	3.08	2.30	3.04	10.36	-	23.9	900
d) Electrical 50/60 Hz : 200/200 - 230 Volt : 3 Phases												
PN25TACMT	6,370	5,478	21,734	2,160	8.20	2.41	1.80	2.95	10.06	-	23.7	900

- Note :**
1. Testing condition ASRE-T, for V code at 1 Phase 220 Volt 50 Hz, for N code at 1 Phase 220 Volt 60 Hz, for Y code at 3 Phases 400 Volt 50 Hz.
  2. All figures indicated are nominal value, for detailed specification, please contact sales representative
  3. Oil type is FV50S

## PN23-33VAAMT/VABMT/VBBMT/YBAMT/TACMT

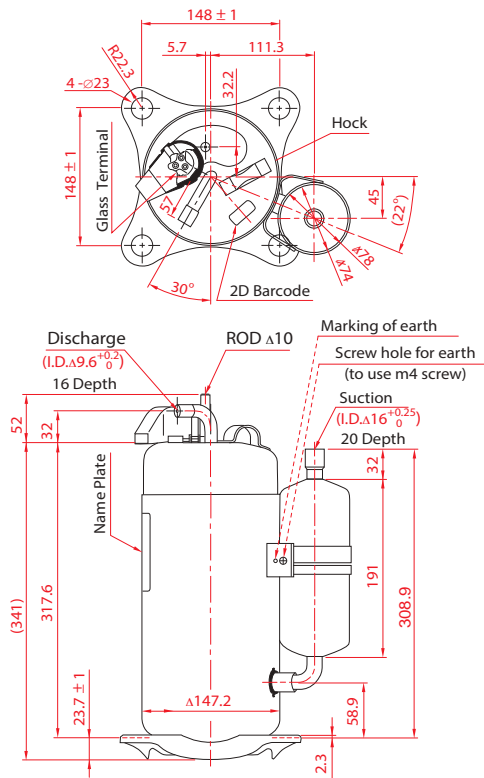

## PN23-27NABMT

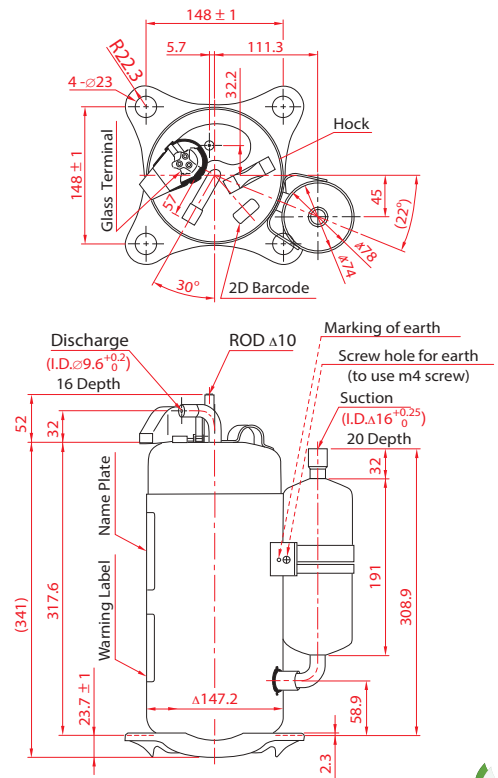



# Specifications of NN Model

Models	Capacity			Input		Nominal Output		COP. (W/W)	EER. (Btu/hr*W)	Run Cap. (µF/VAC)	Weight (kgs.)	Oil Q'ty (cc.)
	W	Kcal/hr	Btu/hr	Watt	Amps	HP	KW.					
<b>High EER Models</b>												
<b>a) Electrical 50 Hz : 220 - 240 Volt : 1 Phase</b>												
NN21VBAMT	5,400	4,644	18,425	1,820	8.30	1.74	1.30	2.97	10.12	50 / 400	29.2	1,200
NN23VBAMT	5,800	4,988	19,790	1,950	9.20	2.01	1.50	2.97	10.15	50 / 400	29.2	1,200
NN25VBAMT	6,300	5,418	21,496	2,120	9.80	2.15	1.60	2.97	10.14	50 / 420	29.8	1,200
NN27VBAMT	6,720	5,779	22,929	2,260	10.40	2.28	1.70	2.97	10.15	55 / 400	30.4	1,200
NN29VAFMT	7,300	6,277	24,908	2,450	11.00	2.55	1.90	2.98	10.17	60 / 450	31.7	1,300
NN31VAFMT	8,000	6,878	27,296	2,660	12.20	2.95	2.20	3.01	10.26	60 / 450	31.8	1,300
NN33VAAMT	8,490	7,301	28,968	2,800	13.10	2.95	2.20	3.03	10.35	55 / 420	31.9	1,300
NN37VAFMT	9,400	8,082	32,073	3,160	14.20	3.49	2.60	2.97	10.15	65 / 420	32.0	1,300
NN40VAAMT	10,200	8,772	34,802	3,430	16.10	3.62	2.70	2.97	10.15	60 / 450	31.9	1,300
<b>b) Electrical 60 Hz : 208 - 230 Volt : 1 Phase</b>												
NN21NBBMT	6,500	5,590	22,178	2,150	9.90	1.74	1.30	3.02	10.32	45 / 400	29.8	1,200
NN23NBBMT	7,200	6,192	24,566	2,380	11.00	2.01	1.50	3.03	10.32	50 / 400	29.5	1,200
NN25NBBMT	7,810	6,716	26,648	2,580	11.70	2.15	1.60	3.03	10.33	55 / 400	30.7	1,200
NN27NBBMT	8,480	7,293	28,934	2,760	12.70	2.28	1.70	3.07	10.48	55 / 400	30.2	1,200
NN29NBBMT	9,100	7,826	31,049	2,950	13.50	2.55	1.90	3.08	10.53	55 / 400	31.3	1,200
NN31NAAMT	10,130	8,712	34,564	3,280	15.10	2.68	2.00	3.09	10.54	60 / 450	32.0	1,300
NN33NAAMT	10,900	9,374	37,191	3,500	16.10	2.95	2.20	3.11	10.63	60 / 450	32.0	1,300
NN37NAAMT	12,190	10,483	41,592	3,920	18.00	3.35	2.50	3.11	10.61	65 / 400	32.0	1,300
NN40NAAMT	13,220	11,369	45,107	4,270	19.60	3.62	2.70	3.10	10.56	65 / 400	32.0	1,300
<b>c) Electrical 50/60 Hz : 380 - 415 Volt : 3 Phases</b>												
NN21YDAMT	5,500	4,730	18,772	1,780	3.00	1.74	1.30	3.09	10.54	-	29.9	1,200
NN25YDAMT	6,580	5,659	22,451	2,120	3.70	2.15	1.60	3.10	10.59	-	29.8	1,200
NN27YDAMT	6,980	6,003	23,816	2,210	3.70	2.28	1.70	3.16	10.78	-	29.9	1,200
NN29YCCMT	7,400	6,363	25,249	2,460	4.50	2.55	1.90	3.01	10.25	-	32.1	1,300
NN31YCCMT	8,000	6,878	27,296	2,600	4.50	2.95	2.20	3.08	10.50	-	32.0	1,300
NN33YCAMT	8,600	7,396	29,343	2,730	4.70	2.95	2.20	3.15	10.75	-	30.1	1,300
NN37YCCMT	9,400	8,082	32,073	3,090	5.10	3.49	2.60	3.04	10.38	-	32.2	1,300
NN40YCAMT	10,400	8,944	35,484	3,300	5.70	3.62	2.70	3.15	10.75	-	31.9	1,300
NN44YCAMT	11,400	9,804	38,897	3,770	6.20	3.62	2.70	3.02	10.25	-	31.9	1,300
<b>d) Electrical 50/60 Hz : 200-230 Volt : 3 Phases</b>												
NN25TDBMT	6,600	5,676	22,519	2,092	7.20	2.28	1.70	3.15	10.76	-	29.7	1,200
NN27TDBMT	6,990	6,011	23,850	2,218	7.70	2.28	1.70	3.15	10.75	-	29.8	1,200
NN31TDBMT	7,960	6,929	27,160	2,570	8.80	2.68	2.00	3.14	10.70	-	30.4	1,300
NN40TKAMT	10,300	8,856	35,144	3,500	11.90	3.62	2.70	2.94	10.04	-	31.0	1,300

**Note :** 1. Testing condition ASRE-T, for V code at 1 Phase 220 Volt 50 Hz, for N code at 1 Phase 220 Volt 60 Hz, for Y code at 3 Phases 400 Volt 50 Hz and 460 Volt 60 Hz.  
 2. All figures indicated are nominal value, for detailed specification, please contact sales representative  
 3. Oil type is FV50S

	Dimension (mm.)					
	A	B	D	E	F	H
NN21-27VBAMT NN21-29NBBMT	327.8	318.6	74.0	16.0	9.6	52.0
NN29-33VAAMT NN31-33NAAMT NN29-37VAFMT NN29-31YCCMT	342.8	393.6	74.0	16.0	9.6	52.0
NN37-40VAAMT NN37-40NAAMT	342.8	393.6	74.0	19.1	9.6	52.0
NN21-27YDAMT NN31-33YCAMT NN25-31TDBMT	327.8	318.6	74.0	16.0	9.6	None
NN40-44YCAMT NN37YCCMT NN40TKAMT	342.8	393.6	74.0	19.1	9.6	None

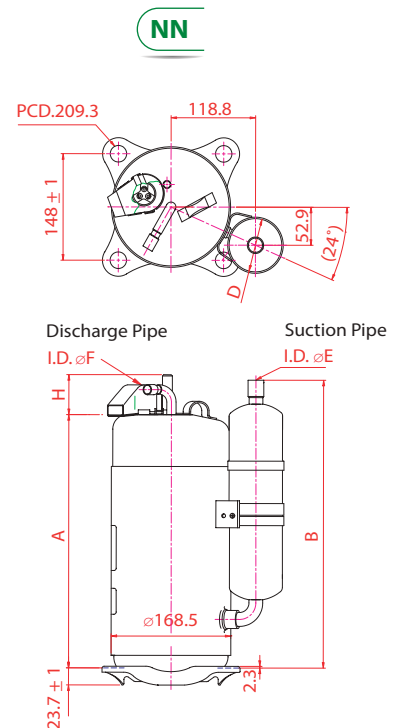

# Operation Standards and Limits of R-410A Compressor KN, RN, PN, NN Model

Models	KN	RN	PN	NN
<b>Compressor</b>				
Type	Rolling Piston Type Rotary			
Displacement (cc/rev.)	9.2 ~ 10.4	9.2 ~ 22.0	23.8 ~ 33.8	21.9 ~ 44.4
Refrigerant type	R-410A			
<b>Pressure</b>				
Condensing	0.2 ~ 4.15 MPaG (29 ~ 602 psiG)			
Evaporating	0.2 ~ 1.60 MPaG (29 ~ 232.1 psiG)			
Compression Ratio	9 or less (See Note 1)			
Abnormal Rise in pressure	5.88 MPaG (852.8 psiG) or less			
<b>Temperature</b>				
Condensing	-27°C ~ + 65°C			
Evaporating	-27°C ~ + 26°C			
Discharged Gas (max)	120°C (248°F), In case of Heat pump or De-humidifier, this limit is 115°C (239°F) (See Note 2)			
Suction Gas (max)	must be over 0°C (No liquid back) (See Note 2)			
Discharged gas's superheat	20°C or more			
Outdoor Ambient Temp.	Air con : 20°C ~ 43 °C (68 °F ~ 109.4 °F), Heat Pump : -10°C ~ 43 °C (14 °F ~ 109.4 °F)			
<b>Electrical</b>				
Supply voltage during operation	Rated voltage ±10%			
Starting voltage	Minimum 80% of rated voltage (at 1.64 MPa balancing pressure) In case of 208-230 V Rated Voltage (N-code compressor), the starting voltage shall be 85% or more. This shall be measured at compressor terminal at instance of start			
Reverse phase (rotation)	Compressor is not designed to run reverse phase			
Frequency range	Rated Frequency ± 2%			
<b>ON/OFF</b>				
ON/OFF Frequency	Less than 170,000 cycles			
ON/OFF Cycle	The ON/OFF cycle shall be a maximum of 10 time/hour. OFF time shall be the time until the high side pressure reach to balance pressure (more than 3 min)			
Pipe Stress	3.5 kg/mm <sup>2</sup> or less at start and stop condition (1.8 kg/mm <sup>2</sup> during operation)			
<b>Refrigerant Circuit</b>				
Maximum Refrigerant Charge	See in General Spec			
Evacuation level	Degree of vacuum equivalent to about 133 Pa (abs) (1.0 mmHg)			
Piping length between indoor and outdoor units	Max. 15 m. ( See also Note 3)	Max. 15 m. for RN092 - RN125 Max. 20 m. for RN130 - RN220	Max. 30 m. ( See also Note 3)	
Elevation between indoor and outdoor units	Max. 7 m. ( See also Note 3)	Max. 7 m. for RN092 - RN125 Max. 15 m. for RN130 - RN220	Max. 20 m. ( See also Note 3)	
Piping vibration	Maximum 0.8 mm.			
Inclination of compressor	Within 5°			

- Note :**
1. High compression ratio test ; C.T./E.T. = 62/-20°C ; has been performed already.
  2. The temperature must be lower than this critical value even the unit has been using for many years.
  3. These Piping Length and Elevation for all series are based on pipe size following this ; Liquid : Ø 9.52 mm. (3/8") Gas : Ø 15.88 mm. (5/8")



### Inverter Technology

Inverter-driven systems can promote maximum compressor efficiency in term of smooth operation. The system can detect subtle temperatures and adjust its capacity output automatically which lead to stable temperature while minimizing power consumption and optimizing humidity control.

Inverter system can control over room temperature to deliver appropriate capacity which is a smart technology that can suitably match cooling and heating performance with operating requirements at specific location so the system can ensure that a room will stay with steady temperature and comfort.

Conventional compressor operates at a fixed speed with on and off repetitively, on the other hand, inverter compressor has controller which can control power output to fit with variable operating environment as well as optimize system therefore amazingly performance in any variant load is ensured throughout the system by means of unit customization and design.

With a proper design concept, the system can reach as higher SEER as 64% comparing with other VRF technology.



### Inverter Benefits

- 1) Precision Temperature Control : unnoticeable swing in temperature because of its adaptation of capacity to match with any variable conditions automatically.
- 2) High Efficiency : deliver only the energy needed to satisfy the cooling or heating condition, thereby saving both energy and cash.
- 3) Humidity Control : enjoy greater comfortable climate with desired level of humidity at a glance.
- 4) Compact size and light weight : Owing to the inverter, motor speed changing technology, inverter compressor is more compact size and light weight comparing to other Variable Refrigerant Flow (VRF) technology by more than 30%.

### Inverter > Technology for the Future

Inverter technology is becoming the new trend in HVAC&R industry in many recently years. The system enhances smoothing performance for every cooling or heating applications. This technology, not only decrease energy usage, but also support those future HVAC requirements such as Multi-system AC, more compact unit, Bulding integration, indoor air quality (IAQ) etc.



# Specifications of Inverter Twin Rotary Compressor

Models	Capacity Range (min~max)			Performance at 60 rps						Weight (kgs.)	Oil Q'ty (cc.)
				Capacity		Input		COP. (w/w)	EER. (Btu/hr*w)		
	Watt	Kcal/hr	BTU/hr	W	BTU/hr	Watt	Amps				

**R-32**  
a) DC Inverter

SVB130FBBMT(10-130RPS)	570~9,070	490~7,798	1,944~30,948	4,200	14,330	1,320	6.40	3.18	10.86	8	350
SVB140F-MT(15-107RPS)	*Under Developing										
SVB172FCKMT(10-130RPS)	690~10,790	593~9,277	2,354~36,817	5,640	19,244	1,810	8.70	3.12	10.63	8.2	400

**R-410**  
a) DC Inverter (ASHRAE - T Condition)

SNB092FQAMT (15-130RPS)	608~6,462	522~5,550	2,074~22,048	2,510	8,564	820	2.9	3.06	10.44	8	350
SNB110FGYMT (15-130RPS)	723~8,046	621~6,918	2,466~27,453	3,400	11,601	1,035	7	3.29	11.21	7.8	350
SNB130FGBMT (10-130RPS)	868~9,679	746~8,322	2,961~33,025	3,630	12,386	1,140	5.4	3.18	10.86	7.9	350
SNB140FRUMT (15-107RPS)	907~5,364	779~4,607	3,094~18,301	3,880	13,239	1,230	3.8	3.15	10.76	8.2	350
SNB172FEKMT (15-130RPS)	1,330~10,835	1,143~9,315	4,538~36,970	4,830	16,480	1,560	6.7	3.1	10.56	8.6	400
TNB220FLHMT (15-120RPS)	1,602~14,392	1,377~12,374	5,466~49,106	7,130	24,328	2,200	9.7	3.24	11.06	14	870
TNB306FPGMT (15-120RPS)	2,245~20,676	1,930~17,777	7,660~70,548	9,880	33,711	3,010	13.5	3.28	11.2	16	870

b) DC Inverter (Heating Condition)

SNB130FGBMT (10-130RPS)	620~6,580	533~5,658	2,116~5,658	3,140	10,714	1,080	5.2	2.91	9.92	7.9	350
SNB172FEKMT (15-130RPS)	780~8,820	671~7,584	2,661~7,584	4,310	14,706	1,450	6.3	2.97	10.14	8.6	400
TNB220FLHMT (15-120RPS)	1,160~11,300	997~9,716	3,958~38,557	5,510	18,800	1,990	8.5	2.77	9.45	14.0	870
TNB306FPGMT (15-120RPS)	1,530~15,870	1,316~13,645	5,220~54,151	8,080	27,569	2,590	10.9	3.12	10.64	16.0	870

- Note :**
- Oil type is FV505
  - At ASHRE-T Condition, min-max frequency 15-130 RPS for SNB092FQAMT, SNB110FGYMT, SNB172FEKMT ; 10-130 RPS for SNB130FGBMT ; 15-107 RPS for SNB140FRUMT ; 15-120 RPS for TNB220FLHMT, TNB306FPGMT ; for other conditions please contact sales representative

	Dimension (mm.)					
	A	B	C	D	E	F
SNB092-130/SVB130	230.1	290.7	93.0	64.5	12.0	8.0
SNB140-172/SVB140-172	235.1	290.7	93.0	64.5	12.0	8.0
TNB220	234.8	273.0	110.5	78.0	16.0	9.5
TNB306	267.6	273.0	110.5	78.0	16.0	9.5

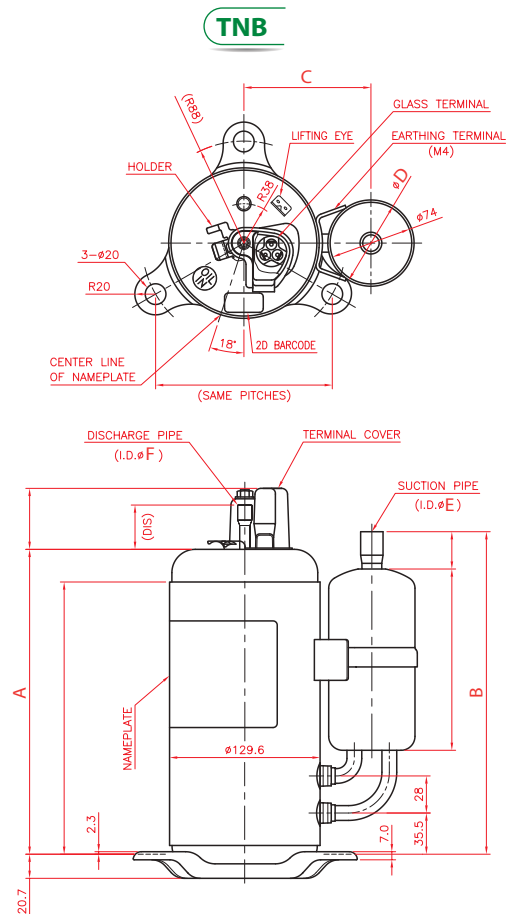
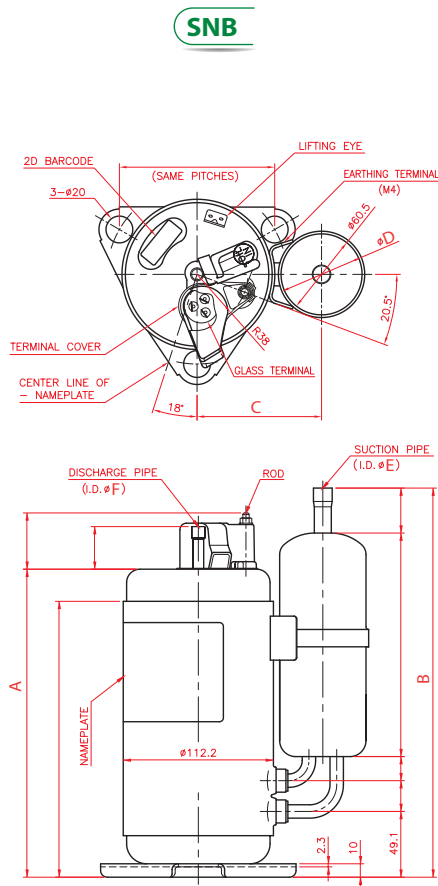

# Operation Standards and Limits of R-32, R-410A Compressor SVB, SNB, TNB Model

Models	SVB	SNB	TNB
Type	Rotary DC inverter		
Displacement (cc/rev.)	13.0 ~ 17.2	9.2 ~ 17.2	22.0 ~ 30.6
Refrigerant type	R-32	R-410A	
Condensing	0.20 ~ 4.17 MPaG ( 29.0 ~ 604.8 psiG)	1.68 ~ 4.15 MPaG (243.6 ~ 602 psiG)	0.2 ~ 4.15 MPaG (29 ~ 602 psiG)
Evaporating	0.20 ~ 1.59 MPaG ( 29.0 ~ 230.6 psiG)	0.47 ~ 1.15 MPaG (68.1 ~ 166.8 psiG)	0.2 ~ 1.6 MPaG (29 ~ 232.1 psiG)
Compression Ratio	9 or less (See Note1)		
Abnormal Rise in pressure	-	6.86 MPaG (994.9 psiG) or less	5.88 MPaG (852.8 psiG) or less
Condensing	- 28°C ~ 64°C	28°C ~ 65°C	-27°C ~ 65°C
Evaporating	- 28°C ~ 25°C	-10°C ~ 15°C	-27°C ~ 26°C
Discharged Gas (max)	115°C (239°F)	120°C (248°F), In case of Heat pump or De-humidifier, this limit is 115°C (239°F) (See Note 2)	
Suction Gas (max)	must be over 0°C (No liquid back) (See Note 2)		
Discharged gas's superheat	20°C or more		
Outdoor Ambient Temp.	Air cond : 20°C ~ 43°C (68°F ~ 109.4°F), Heat Pump : -10°C ~ 43°C (14°F ~ 109.4°F)		
Supply voltage during operation	The compressor must be operated on the proper voltage in accordance with the frequency (or the revolution) as shown the performance curve. The applied voltage's phase of the compressor must be neatly accoded with the phase of rotor in the compressor. The operating voltage shall be the terminal voltage of the compressor during operation.		
Starting voltage	(Asynchronous drive at start-up). The compressor motor must be operated by suitable power supply voltage and revolution for unit condition without reverse rotation. The unit condition at start-up must be balanced the high/low pressure at 1.64 MPa for SNB and 2.49 MPa for TNB		
Reverse phase (rotation)	Compressor is not designed to run reverse phase		
Frequency range	See in compressor specification		
ON/OFF Frequency	Less than 170,000 cycles		
ON/OFF Cycle	The ON/OFF cycle shall be a maximum of 10 time / hour. OFF time shall be the time until the high side pressure reach to balance pressure (more than 3 min)		
Pipe Stress	3.5 Kg/mm <sup>2</sup> or less at start and stop condition (1.8kg/mm <sup>2</sup> during operation) Refrigerant Circuit		
Evacuation level	Degree of vaccum equivalent to about 133 Pa (abs) (1.0 mmHg)		
Piping length between indoor and outdoor units	Max. 15 m. ( See also Note 3)		Max. 20 m. ( See also Note 3)
Elevation between indoor and outdoor units	Max. 7 m. ( See also Note 3)		Max. 15 m. ( See also Note 3)
Piping vibration	Maximum 0.8 mm.		
Inclination of compressor	Within 5°		

- Note :**
1. High compression ratio test ; C.T./E.T. = 62/-12°C ; has been performed already.
  2. The temperature must be lower than this critical value even the unit has been using for many years.
  3. These Piping Length and Elevation for all series are based on pipe size following this ; Liquid : Ø 9.52 mm. (3/8") Gas : Ø15.88 mm. (5/8")



# Specifications of RB Model & Operation Standards and Limits of R-134A Compressor RB Model

Models	Capacity			Input		Normal Output		COP. (W/W)	EER. (Btu/hr*W)	Run Cap. (µF/VAC)	Weight (kgs.)	Oil Q'ty (cc.)
	W	Kcal/hr	Btu/hr	Watt	Amps	HP	KW.					
<b>High EER Models</b>												
a) Electrical 50 Hz : 220 - 240 Volt : 1 Phase												
RB135VRYMT	1,560	1,341	5,323	500	2.30	0.58	0.43	3.12	10.65	25 / 370	12.7	300
RB145VHSMT	1,700	1,462	5,800	560	2.60	0.67	0.50	3.04	10.36	25 / 370	13.2	300
RB154VHSMT	1,740	1,496	5,937	610	2.80	0.74	0.55	2.85	9.73	25 / 370	13.2	300
RB165VHSMT	1,920	1,651	6,551	650	3.00	0.79	0.59	2.95	10.08	25 / 370	13.2	300
RB174VRXMT	2,000	1,720	6,824	640	3.00	0.80	0.60	3.13	10.66	25 / 370	13.5	440
RB189VHSMT	2,210	1,900	7,541	720	3.30	0.82	0.61	3.07	10.47	30 / 370	15.1	520
RB247VRYMT	2,880	2,476	9,827	900	4.20	1.14	0.85	3.20	10.92	30 / 400	15.4	520
RB277VHSMT	3,240	2,786	11,055	1,060	5.10	1.23	0.92	3.06	10.43	40 / 370	15.1	520
RB313VHSMT	3,730	3,207	12,727	1,290	6.10	1.27	0.95	2.89	9.87	45 / 370	15.7	520

- Note :**
1. Testing condition ASRE-T, for V code at 1 Phase 220 Volt 50 Hz.
  2. All figures indicated are nominal value, for detailed specification, please contact sales representative.
  3. Oil type is FV50S.

	Dimension (mm.)					
	A	B	C	D	E	F
RB135-174VHSMT	211.3	240.8	101.0	65.1	9.6	8.0
RB135VRYMT						
RB189-277	256.2	260.5	110.5	78.0	12.7	8.0
RB313VHSMT	261.2	287.5	110.5	78.0	12.7	9.6
RB174VRXMT	211.3	242.8	110.5	78.0	12.7	8.0

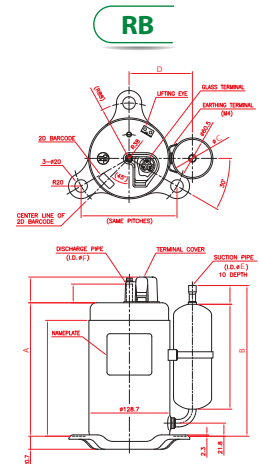

Models	RB
<b>Compressor</b>	
Type	Rolling Piston Type Rotary
Displacement (cc/rev.)	13.5 ~ 31.3
Refrigerant type	R-134A
<b>Pressure</b>	
Maximum Condensing	0.03 ~ 2.60 MPaG (4.4 ~ 377.1 psiG)
Evaporating	0.03 ~ 0.69 MPaG (4.4 ~ 100.1 psiG)
Compression Ratio	10 or less ( See Note 1)
Abnormal Rise in pressure	2.94 MPaG (426.4 psiG) or less
<b>Temperature</b>	
Condensing	-20°C ~ 81°C
Evaporating	-20°C ~ 31°C
Discharged Gas (max)	115°C (239°F), In case of Heat pump or De-humidifier, this limit is 110°C (230°F) (See Note 2)
Suction Gas (max)	must be over 0°C (No liquid back) (See Note 2)
Discharged gas 's superheat	20°C or more
Outdoor Ambient Temp.	Air cond : 20°C ~ 43°C (68°F ~ 109.4°F) Heat Pump : -10°C ~ 43°C (14°F ~ 109.4°F)
<b>Electrical</b>	
Supply voltage during operation	Rated voltage ±10%
Starting voltage	Minimum 80% of rated voltage (at 1.01MPa balancing pressure) In case of 208 - 230 V Rated Voltage (N-code compressor), the starting voltage shall be 85% or more. This shall be measured at compressor terminal at instance of start
Reverse phase (rotation)	Compressor is not design to run reverse phase
Frequency range	Rated Frequency ± 2%
<b>ON/OFF</b>	
ON/OFF Frequency	Less than 170,000 cycles
ON/OFF Cycle	The ON/OFF cycle shall be a maximum of 10 time/hour. OFF time shall be the time until the high side pressure reach to balance pressure (more than 3 min)
Pipe Stress	3.5 kg/mm <sup>2</sup> or less at start and stop condition (1.8 kg/mm <sup>2</sup> during operation)
<b>Refrigerant Circuit</b>	
Maximum Refrigerant Charge	See in General Spec
Evacuation level	Degree of vaccum equivalent to about 133 Pa (abs) (1.0mmHg)
Piping length between indoor and outdoor units	Max. 15 m. for RB135 - RB174 Max. 20 m. for RB189 - RB 313
Elevation between indoor and outdoor units	Max. 7 m. for RB135 - RB174 Max. 15 m. for RB189 - RB 313
Piping vibration	Maximum 0.8 mm.
Inclination of compressor	Within 5°

- Note :**
1. High compression ratio test ; C.T./E.T. = 62/-12°C ; has been performed already.
  2. The temperature must be lower than this critical value even the unit has been using for many years.
  3. These Piping Length and Elevation for all series are based on pipe size following this ; Liquid : Ø 9.52 mm. (3/8") Gas : Ø 15.88 mm. (5/8")

# Specifications of KV, RV, PV Model

Models	Capacity			Input		Normal Output		COP. (W/W)	EER. (Btu/hr*w)	Run Cap. (µF/VAC)	Weight (kgs.)	Oil Q'ty (cc.)
	W	Kcal/hr	Btu/hr	Watt	Amps	HP	KW.					
<b>High EER Models</b>												
a) Electrical 50 Hz : 220 - 240 Volt : 1 Phase												
KV092VBBMT	2,295	1,974	7,831	850	3.90	0.94	0.70	2.70	9.21	25/370	9.9	300
RV092VDCMT	2,240	1,926	7,643	820	3.80	0.94	0.70	2.73	9.32	25/370	14.0	300
RV125VABMT	2,950	2,537	10,065	1,100	5.10	1.21	0.90	2.68	9.15	30/370	16.0	420
RV130VCAMT	3,270	2,812	11,157	1,140	5.20	1.21	0.90	2.87	9.79	30/370	14.8	420
RV135VCAMT	3,400	2,924	11,601	1,180	5.50	1.21	0.90	2.88	9.83	30/370	15.1	420
RV145VFAMT	3,700	3,182	12,624	1,280	5.90	1.39	1.04	2.89	9.86	35/370	15.9	420
RV174VAAMT	4,460	3,836	15,218	1,530	7.20	1.74	1.30	2.92	9.95	40/370	15.6	440
RV220VBBMT	5,510	4,739	18,800	1,950	9.10	2.15	1.60	2.83	9.64	45/400	16.6	440
RV231VFFMT	5,960	5,126	20,336	2,080	9.90	2.15	1.60	2.87	9.78	50/400	17.3	520
PV23VAAMT	5,880	5,057	20,063	2,080	9.40	2.41	1.80	2.83	9.65	60/420	23.7	670

- Note :**
1. Testing condition ARI, for V code at 1 Phase 220 Volt 50 Hz.
  2. All figures indicated are nominal value, for detailed specification, please contact sales representative.
  3. Oil type is FW68S.

	Dimension (mm.)					
	A	B	C	D	E	F
KV	244.1	249.5	93.0	64.5	12.0	8.0
RV092	213.1	243.8	101.0	65.1	9.6	9.6
RV125-135	257.5	260.5	110.5	78.0	12.7	9.6
RV145	264.7	260.5	110.5	78.0	12.7	9.6
RV174-189	257.5	287.5	110.5	78.0	12.7	9.6
RV220	269.5	287.5	110.5	78.0	12.7	9.6
RV231	276.7	289.5	110.5	78.0	16.0	9.6
PV23	317.6	308.9	-	79.0	16.0	9.6

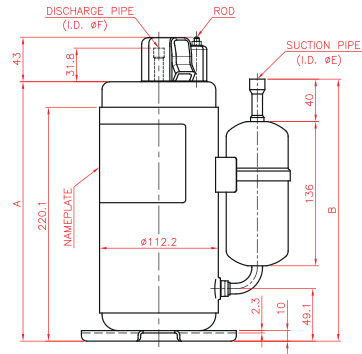
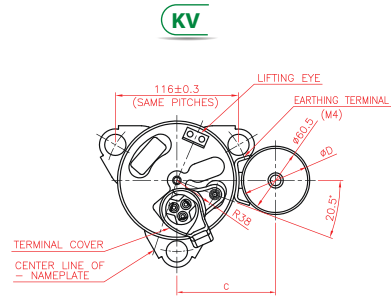

**RV**

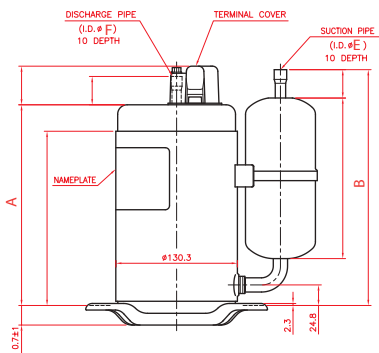
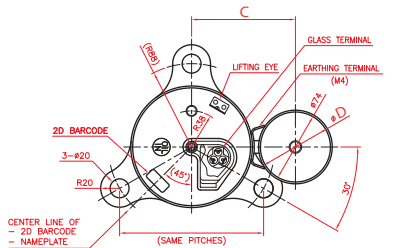

**PV**

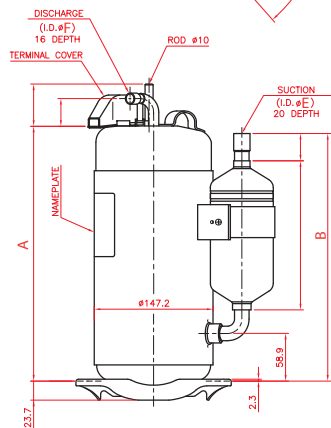
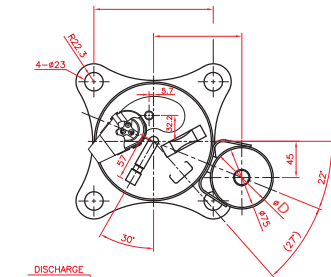

# Operation Standards and Limits of R-32 Compressor KV, RV, PV Model

Models	KV	RV	PV
<b>Compressor</b>			
Type	Rolling Piston Type Rotary		
Displacement (cc/rev.)	9.2	9.2 ~ 22.0	23.8
Refrigerant type	R-32		
<b>Pressure</b>			
Condensing	0.21 ~ 4.28 MPaG (30.5 ~ 620.8 psiG)		
Evaporating	0.21 ~ 1.63 MPaG (30.5 ~ 236.4 psiG)		
Compression Ratio	9 or less		
Abnormal Rise in pressure	5.88 MPaG (852.8 psiG) or less		
<b>Temperature</b>			
Condensing	-27°C ~ +65°C		
Evaporating	-27°C ~ +26°C		
Discharged Gas (max)	120°C (248°F), In case of Heat pump or De-humidifier, this limit is 115°C (239°F) (See Note 2)		
Suction Gas (max)	must be over 0°C (No liquid back) (See Note 2)		
Discharged gas 's superheat	20°C or more		
Outdoor Ambient Temp.	Air cond : 20°C ~ 50°C (68°F ~ 122°F), Heat Pump : -10°C ~ 50°C (14°F ~ 122°F)		
<b>Electrical</b>			
Supply voltage during operation	Rated voltage ±10%		
Starting voltage	Minimum 80% of rated voltage (at 1.64 MPa balancing pressure) In case of 208 - 230 V Rated Voltage (N-code compressor), the starting voltage shall be 85% or more. This shall be measured at compressor terminal at instance of start		
Reverse phase (rotation)	Compressor is not designed to run reverse phase		
Frequency range	Rated Frequency ± 2%		
<b>ON/OFF</b>			
ON/OFF Frequency	Less than 170,000 cycles		
ON/OFF Cycle	The ON/OFF cycle shall be a maximum of 10 time/hour. OFF time shall be the time until the high side pressure reach to balance pressure (more than 3 min)		
Pipe Stress	3.5 kg/mm <sup>2</sup> or less at start and stop condition (1.8 kg/mm <sup>2</sup> during operation)		
<b>Refrigerant Circuit</b>			
Maximum Refrigerant Charge	See in General Spec		
Evacuation level	Degree of vacuum equivalent to about 133 Pa (abs) (1.0 mmHg)		
Piping length between indoor and outdoor units	Max. 15 m. ( See also Note 3)	Max. 15 m. for RV092 - RV125 Max. 20 m. for RV130 - RV231	Max. 30 m. ( See also Note 3)
Elevation between indoor and outdoor units	Max. 7 m. ( See also Note 3)	Max. 7 m. for RV092 - RV125 Max. 15 m. for RV130 - RV231	Max. 20 m. ( See also Note 3)
Piping vibration	Maximum 0.8 mm.		
Inclination of compressor	Within 5°		

- Note :**
1. High compression ratio test ; C.T./E.T. = 62/-12°C ; has been performed already.
  2. The temperature must be lower than this critical value even the unit has been using for many years.
  3. These Piping Length and Elevation for all series are based on pipe size following this ; Liquid : Ø 9.52 mm. (3/8") Gas : Ø 15.88 mm. (5/8")





# Specifications of RE Model

Models	Capacity			Input		Normal Output		COP. (W/W)	EER. (Btu/hr*w)	Run Cap. (µF/VAC)	Weight (kgs.)	Oil Q'ty (cc.)
	W	Kcal/hr	Btu/hr	Watt	Amps	HP	KW.					
<b>High EER Models</b>												
<b>RE</b>												
<b>a) Electrical 50 Hz : 220 - 240 Volt : 1 Phase</b>												
RE135VHSMT	2,240	1,926	7,463	730	3.30	0.87	0.65	3.07	10.47	25 / 370	13.2	300
RE145VHSMT	2,420	2,081	8,257	790	3.60	0.94	0.70	3.06	10.45	25 / 370	13.2	300
RE154VHSMT	2,580	2,219	8,803	840	3.80	1.01	0.75	3.07	10.48	25 / 370	13.2	300
RE165VHSMT	2,770	2,382	9,451	890	4.10	1.07	0.80	3.11	10.62	25 / 370	13.2	300
RE174VHSMT	2,920	2,511	9,963	940	4.30	1.07	0.80	3.11	10.60	25 / 370	13.2	300
RE189VHSMT	3,210	2,761	10,953	1,010	4.80	1.14	0.85	3.18	10.84	30 / 370	15.1	520
RE197VHSMT	3,330	2,864	11,362	1,050	5.00	1.21	0.90	3.17	10.82	30 / 370	15.1	520
RE207VHSMT	3,520	3,027	12,010	1,110	5.20	1.34	1.00	3.17	10.82	30 / 370	15.1	520
RE231VHSMT	3,940	3,388	13,443	1,250	5.90	1.48	1.10	3.15	10.75	30 / 400	15.1	520
RE247VHSMT	4,220	3,629	14,399	1,340	6.40	1.61	1.20	3.15	10.75	35 / 400	15.1	520
RE277VHSMT	4,700	4,042	16,036	1,520	7.20	1.74	1.30	3.09	10.55	40 / 370	15.1	520
RE313VADMT	5,380	4,626	18,357	1,770	8.34	1.74	1.30	3.04	10.37	45 / 370	15.7	520
<b>b) Electrical 60 Hz : 115 - 120 Volt : 1 Phase</b>												
RE135WHHMT	2,850	2,451	9,724	890	7.89	0.87	0.65	3.20	10.93	75 / 220	13.3	300
RE174WHHMT	3,640	3,130	12,420	1,130	9.93	1.14	0.85	3.22	10.99	85 / 220	13.2	300
<b>c) Electrical 60 Hz : 208 - 230 Volt : 1 Phase</b>												
RE135NHHMT	2,720	2,338	9,281	868	4.12	0.87	0.65	3.13	10.67	25 / 370	13.3	300
RE174NHHMT	3,610	3,104	12,317	1,138	4.19	1.07	0.80	3.17	10.82	25 / 370	13.2	300
RE189NRAMT	4,000	3,439	13,648	1,280	6.00	1.20	0.90	3.13	10.66	30 / 370	15.1	520
RE207NRAMT	4,250	3,654	14,501	1,350	6.34	1.34	1.00	3.15	10.74	30 / 370	15.1	520
RE231NRAMT	4,760	4,093	16,241	1,511	6.96	1.48	1.10	3.15	10.75	30 / 370	15.1	520
RE277NRAMT	5,660	4,867	19,312	1,805	8.55	1.74	1.30	3.14	10.70	40 / 370	15.4	520

- Note :**
1. Testing condition ASRE-T, for V code at 1Phase 220Volt 50Hz, for N code at 1Phase 220Volt 60Hz, for W code at 1Phase 115Volt 60Hz
  2. All figures indicated are nominal value, for detailed specification, please contact sales representative
  3. Oil type is FV505(5/8")

	Dimension (mm.)					
	A	B	C	D	E	F
RE135-174VHSMT	211.3	240.8	101.0	60.5	9.6	8.0
RE135-174WHHMT						
RE135-174NHHMT						
RE189-277VHSMT	256.2	260.5	110.5	74.0	12.7	8.0
RE207-277NRAMT						
RE313VADMT	261.2	282.5	110.5	74.0	12.7	9.7

**RE**

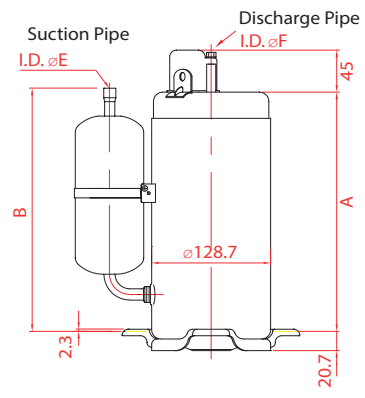
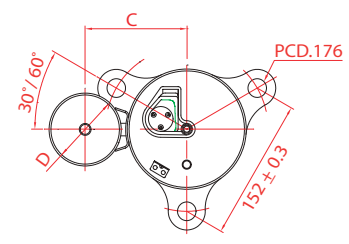

# Specifications of PE, NE Model

Models	Capacity			Input		Normal Output		COP. (W/W)	EER. (Btu/hr*w)	Run Cap. (µF/VAC)	Weight (kgs.)	Oil Q'ty (cc.)
	W	Kcal/hr	Btu/hr	Watt	Amps	HP	KW.					

## High EER Models

### PE

#### 4Legs

a) Electrical 50 Hz : 220 - 240 Volt : 1 Phase

PE33VPENT	5,777	4,967	19,711	1,850	8.60	2.01	1.50	3.12	10.65	50 / 370	22.7	900
PE36VPENT	6,227	5,354	21,247	2,010	9.40	2.15	1.60	3.10	10.57	55 / 400	22.7	900
PE39VPENT	6,664	5,730	22,738	2,150	10.10	2.28	1.70	3.10	10.58	60 / 450	22.7	900
PE41VPJMT	7,360	6,328	25,114	2,305	10.80	2.55	1.90	3.19	10.89	60 / 450	22.3	900

b) Electrical 60 Hz : 208 - 230 Volt : 1 Phase

PE33NPBMT	6,877	5,917	23,464	2,210	10.40	2.01	1.50	3.11	10.62	35 / 370	22.7	900
PE36NPBMT	7,427	6,386	25,341	2,400	11.30	2.15	1.60	3.09	10.56	35 / 370	22.7	900
PE39NPBMT	7,981	6,862	27,231	2,580	12.10	2.28	1.70	3.09	10.55	35 / 370	22.7	900

#### 3Legs

a) Electrical 50 Hz : 220 - 240 Volt : 1 Phase

PE33VTEMT	5,777	4,967	19,711	1,850	8.60	2.01	1.50	3.12	10.65	50 / 370	22.7	900
PE36VTEMT	6,227	5,354	21,247	2,010	9.40	2.15	1.60	3.10	10.57	55 / 400	22.7	900
PE39VTEMT	6,664	5,730	22,738	2,150	10.10	2.28	1.70	3.10	10.58	60 / 450	22.7	900
PE41VTJMT	7,360	6,328	25,114	2,305	10.80	2.55	1.90	3.19	10.89	60 / 450	22.3	900

b) Electrical 60 Hz : 208 - 230 Volt : 1 Phase

PE33NTBMT	6,877	5,913	23,464	2,210	10.40	2.01	1.50	3.11	10.62	35 / 370	22.7	900
PE36NTBMT	7,427	6,386	25,341	2,400	11.30	2.15	1.60	3.09	10.56	35 / 370	22.7	900
PE39NTBMT	7,981	6,862	27,231	2,580	12.10	2.28	1.70	3.09	10.55	35 / 370	22.7	900

## High EER Models

### NE

a) Electrical 50 Hz : 220 - 240 Volt : 1 Phase

NE41VNHMT	7,270	6,252	24,805	2,330	10.60	2.55	1.90	3.12	10.65	45 / 420	31.3	1,300
NE44VNHMT	7,850	6,751	26,784	2,500	11.70	2.68	2.00	3.14	10.71	50 / 420	31.3	1,300
NE47VNHMT	8,380	7,207	28,593	2,670	12.40	2.95	2.20	3.14	10.71	50 / 420	32.2	1,300
NE52VNHMT	9,380	8,067	32,005	3,020	14.10	3.35	2.50	3.11	10.60	60 / 450	32.2	1,300
NE56VNHMT	10,260	8,824	35,007	3,360	15.90	3.62	2.70	3.05	10.42	60 / 420	32.2	1,300

b) Electrical 50/60 Hz : 380 - 415 Volt : 3 Phases

NE41YDNMT	7,150	6,149	24,396	2,210	3.80	2.55	1.90	3.24	11.04	-	30.3	1,300
NE44YDNMT	7,790	6,699	26,579	2,420	4.10	2.68	2.00	3.22	10.98	-	30.3	1,300
NE47YDNMT	8,350	7,181	28,490	2,580	4.50	2.95	2.20	3.24	11.04	-	30.3	1,300
NE52YDNMT	9,480	8,153	32,346	2,950	5.20	3.35	2.50	3.21	10.96	-	31.3	1,300
NE56YDNMT	10,200	8,772	34,802	3,240	5.60	3.62	2.70	3.15	10.74	-	32.2	1,300

- Note :**
1. Testing condition ASRE-T, for V code at 1Phase 220Volt 50Hz, for N code at 1Phase 220Volt 60Hz.
  2. All figures indicated are nominal value, for detailed specification, please contact sales representative.
  3. Oil type is FV50S.

		Dimension (mm.)					
		A	B	D	E	F	H
PE (4Legs)	PE33-39VPENT	316.3	308.9	74.0	16.0	9.6	52.0
	PE33-39NPBMT						
	PE41VPJMT	316.3	308.9	74.0	16.0	9.6	None
PE (3Legs)	PE33-39VTEMT	316.3	308.9	74.0	16.0	9.6	52.0
	PE33-39NTBMT						
	PE41VTJMT	316.3	308.9	74.0	16.0	9.6	None
NE	NE41-56VNHMT	341.3	392.3	74.0	16.0	9.6	52.0
	NE41-56YDNMT	341.3	392.3	74.0	16.0	9.6	None



### PE (4Legs)

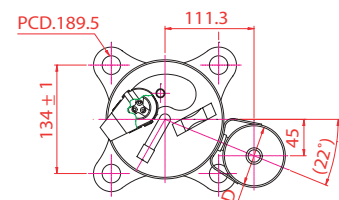

### Discharge Pipe

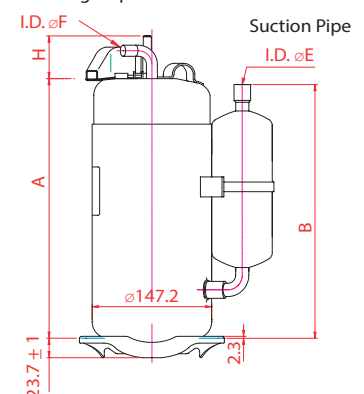

# Operation Standards and Limits of R-407C Compressor RE, PE, NE Model

Models	RE	PE	NE
<b>Compressor</b>			
Type	Rolling Piston Type Rotary		
Displacement (cc/rev.)	13.5 ~ 31.3	28.1 ~ 41.7	28.0 ~ 38.8, 41.8 ~ 56.9
Refrigerant type	R-407C		
<b>Pressure</b>			
Maximum Condensing	1.10 ~ 2.83 MPaG (159.5 ~ 410.4 psiG)		
Evaporating	0.26 ~ 0.73 MPaG (37.7~105.9 psiG)		
Compression Ratio	6 or less	8 or less (See Note 1)	
Abnormal Rise in pressure	4.9 MPaG (710.6 psiG) or less		
<b>Temperature</b>			
Condensing	28°C ~ + 65°C		
Evaporating	-10°C ~ 15°C		
Discharged Gas (max)	120°C (248°F), In case of Heat pump or De-humidifier, this limit is 115°C (239°F) (See Note 2)		
Suction Gas (max)	must be over 0°C (No liquid back) (See Note 2)		
Discharged gas 's superheat	20°C or more		
Outdoor Ambient Temp.	Air cond : 20°C ~ 43°C (68°F ~ 109.4°F) Heat Pump : -10°C ~ 43°C (14°F ~ 109.4°F)		
<b>Electrical</b>			
Supply voltage during operation	Rated voltage ±10%		
Starting voltage	Minimum 80% of rated voltage (at 1.01 MPa balancing pressure) In case of 208- 230 V Rated Voltage (N-code compressor), the starting voltage shall be 85% or more. This shall be measured at compressor terminal at instance of start		
Reverse phase (rotation)	Compressor is not designed to run reverse phase		
Frequency range	Rated Frequency ± 2%		
<b>ON/OFF</b>			
ON/OFF Frequency	Less than 170,000 cycles		
ON/OFF Cycle	The ON/OFF cycle shall be a maximum of 10 time/hour. OFF time shall be the time until the high side pressure reach to balance pressure (more than 3 min)		
Pipe Stress	3.5 kg/mm <sup>2</sup> or less at start and stop condition (1.8 kg/mm <sup>2</sup> during operation)		
<b>Refrigerant Circuit</b>			
Maximum Refrigerant Charge	See in General Spec		
Evacuation level	Degree of vacuum equivalent to about 133 Pa (abs) (1.0 mmHg)		
Piping length between indoor and outdoor units	Max. 15 m. for RE130 - RE174 Max. 20 m. for RE189 - RE 313	Max. 30 m. ( See also Note 3)	
Elevation between indoor and outdoor units	Max. 7 m. for RE130 - RE174 Max. 15 m. for RE189 - RE 313	Max. 20 m. ( See also Note 3)	
Piping vibration	Maximum 0.8 mm.		
Inclination of compressor	Within 5°		

- Note :**
1. High compression ratio test ; C.T./E.T. = 62/-12°C ; has been performed already.
  2. The temperature must be lower than this critical value even the unit has been using for many years.
  3. These Piping Length and Elevation for all series are based on pipe size following this ; Liquid : Ø 9.52 mm. (3/8") Gas : Ø 15.88 mm. (5/8")

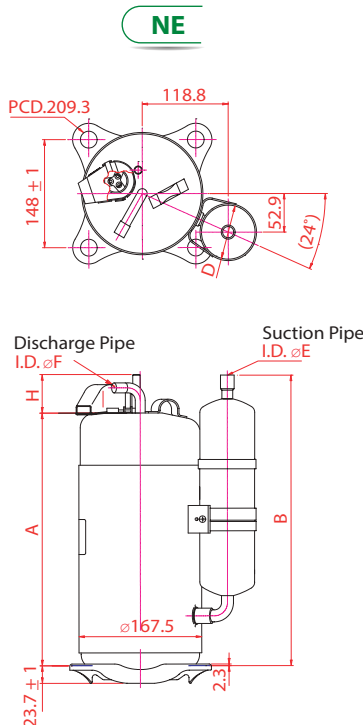
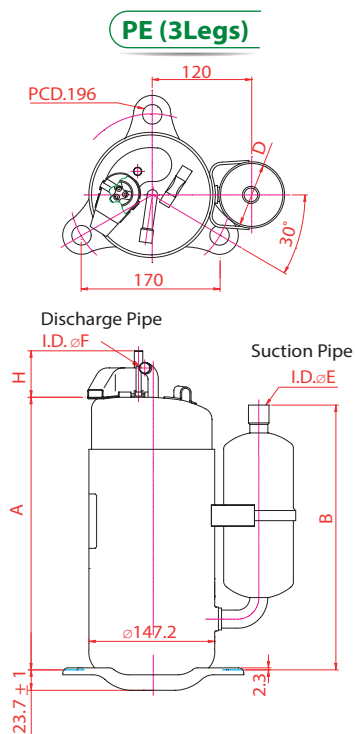

# Specifications of RH Model

Models	Capacity			Input		Normal Output		COP. (W/W)	EER. (Btu/hr*w)	Run Cap. (µF/VAC)	Weight (kgs.)	Oil Q'ty (cc.)
	W	Kcal/hr	Btu/hr	Watt	Amps	HP	KW.					

## High EER Models

a) Electrical 50 Hz : 220 - 240 Volt : 1 Phase

RH130VHST	2,255	1,939	7,694	700	3.22	0.87	0.65	3.22	10.99	25/370	13.3	300
RH135VHST	2,325	1,999	7,933	720	3.31	0.87	0.65	3.23	11.02	25/370	13.3	300
RH145VHST	2,488	2,139	8,489	770	3.56	0.94	0.70	3.23	11.02	25/370	13.3	300
RH154VHST	2,662	2,289	9,083	820	3.79	1.01	0.75	3.25	11.08	25/370	13.3	300
RH165VHST	2,872	2,469	9,799	890	4.12	1.07	0.80	3.23	11.01	25/370	13.3	300
RH174VHST	2,998	2,578	10,229	930	4.30	1.14	0.85	3.22	11.00	25/370	13.3	300
RH197VHST	3,468	2,982	11,833	1,058	4.92	1.34	1.00	3.28	11.18	30/370	15.4	520
RH207VHST	3,670	3,156	12,522	1,140	5.30	1.34	1.00	3.22	10.98	30/370	15.4	520
RH220VHST	3,906	3,359	13,327	1,210	5.65	1.41	1.05	3.23	11.01	30/370	15.4	520
RH247VHST	4,372	3,759	14,917	1,360	6.32	1.61	1.20	3.21	10.97	35/370	15.4	520
RH277VHST	4,848	4,169	16,541	1,530	7.10	1.74	1.30	3.17	10.81	40/370	15.4	520
RH313VAGT	5,640	4,850	19,244	1,746	8.43	1.74	1.30	3.23	11.02	45/370	15.7	520
RH313VAJT	5,640	4,850	19,244	1,746	8.43	1.74	1.30	3.23	11.02	45/370	15.7	520

b) Electrical 60 Hz : 115 - 120 Volt : 1 Phase

RH130WHHT	2,697	2,319	9,202	850	7.50	0.87	0.65	3.17	10.83	75/220	13.3	300
RH140WHHT	2,918	2,509	9,956	920	8.15	0.94	0.70	3.17	10.82	80/220	13.3	300
RH145WHHT	3,046	2,619	10,393	960	8.50	0.94	0.70	3.17	10.83	80/220	13.3	300
RH165WHHT	3,453	2,969	11,782	1,090	9.65	1.07	0.80	3.17	10.81	85/220	13.3	300
RH189WRAT	4,011	3,449	13,686	1,270	11.25	1.21	0.90	3.16	10.78	100/220	15.4	520
RH197WRAT	4,081	3,509	13,924	1,300	11.50	1.21	0.90	3.14	10.71	100/220	15.4	520

c) Electrical 60 Hz : 208 - 230 Volt : 1 Phase

RH130NHHT	2,697	2,319	9,202	840	3.85	0.87	0.65	3.21	10.95	25/370	13.3	300
RH135NHHT	2,825	2,429	9,639	885	4.10	0.87	0.65	3.19	10.89	25/370	13.3	300
RH140NHHT	3,000	2,580	10,236	935	4.30	0.94	0.70	3.21	10.95	25/370	13.3	300
RH145NHHT	3,070	2,640	10,475	950	4.40	0.94	0.70	3.23	11.03	25/370	13.3	300
RH154NHHT	3,220	2,769	10,987	995	4.58	1.01	0.75	3.24	11.04	30/370	13.3	300
RH167NRAT	3,558	3,059	12,140	1,100	5.06	1.07	0.80	3.23	11.04	30/370	15.4	300
RH174NHHT	3,745	3,220	12,778	1,160	5.35	1.07	0.80	3.23	11.02	25/370	13.3	520
RH189NRAT	4,047	3,480	13,808	1,250	5.76	1.21	0.90	3.24	11.05	30/370	15.4	300
RH197NRAT	4,209	3,619	14,361	1,305	6.00	1.21	0.90	3.23	11.00	30/370	15.4	520
RH207NRAT	4,418	3,799	15,074	1,370	6.35	1.34	1.00	3.22	11.00	30/370	15.4	520
RH220NRAT	4,674	4,019	15,948	1,450	6.70	1.48	1.10	3.22	11.00	35/370	15.4	520
RH231NRAT	4,941	4,248	16,859	1,540	7.16	1.48	1.10	3.21	10.95	35/370	15.4	520
RH247NRAT	5,267	4,529	17,971	1,650	7.65	1.61	1.20	3.19	10.89	35/370	15.4	520
RH277NRAT	5,884	5,059	20,076	1,840	8.55	1.74	1.30	3.20	10.91	40/370	15.4	520
RH313NRAT	6,700	5,761	22,860	2,140	9.91	2.41	1.80	3.13	10.68	45/400	15.7	520

## Premium High EER Models

a) Electrical 50 Hz : 220 - 240 Volt : 1 Phase

RH197VHRT	3,610	3,104	12,317	1,060	5.12	1.34	1.00	3.41	11.62	30/370	15.1	520
RH207VHRT	3,712	3,192	12,665	1,097	5.21	1.34	1.00	3.38	11.55	30/370	15.1	520
RH207VRJT	3,740	3,216	12,761	1,090	5.14	1.34	1.00	3.43	11.71	30/370	15.1	420
RH277VRNT	4,780	4,110	16,309	1,480	6.85	1.70	1.30	3.23	11.02	40/370	15.3	440
RH277VHRT	4,930	4,239	16,821	1,507	7.16	1.74	1.30	3.27	11.16	40/370	15.4	520
RH313VAMT	5,650	4,858	19,278	1,700	7.95	1.70	1.30	3.32	11.34	50/370	16.1	520

b) Electrical 60 Hz : 208 - 230 Volt : 1 Phase

RH207NRHT	4,580	3,938	15,627	1,355	6.28	1.34	1.00	3.38	11.53	35/370	15.4	520
-----------	-------	-------	--------	-------	------	------	------	------	-------	--------	------	-----

## Compact Models

a) Electrical 50 Hz : 220 - 240 Volt : 1 Phase

RH207VRFT	3,600	3,095	12,283	1,150	5.30	1.34	1.00	3.13	10.68	40/400	12.4	440
RH220VRFT	3,850	3,310	13,136	1,240	5.80	1.34	1.00	3.10	10.59	40/400	12.4	440

- Note :**
1. Testing condition ASRE-T, for V code at 1Phase 220 Volt 50 Hz, for N code at 1 Phase 220 Volt 60 Hz, for W code at 1 Phase 115 Volt 60 Hz.
  2. All figures indicated are nominal value, for detailed specification, please contact sales representative.
  3. Oil type is NM 56 EP.

	Dimension (mm.)					
	A	B	C	D	E	F
RH130-174VHST						
RH130-165WHHT	211.3	240.8	101.0	60.5	9.6	8.0
RH130-174NHHT						
RH207-220VRFT	211.3	240.8	101.0	60.5	12.7	8.0
RH189-277NRAT	246.2	258.5	101.0	60.5	9.6	8.0
RH277NRHT						
RH189-277VHST						
RH189-197WRAT	256.2	260.5	110.5	74.0	12.7	8.0
RH197-207VHRT						
RH207VRJT						
RH277VHRT	256.2	265.5	110.5	74.0	12.7	8.0
RH313VAGT	261.2	282.5	110.5	74.0	12.7	9.6
RH313VAJT						
RH313NRAT	261.2	289.5	110.5	74.0	16.0	9.6
RH313VAMT	268.2	287.5	110.5	74.0	12.7	9.6

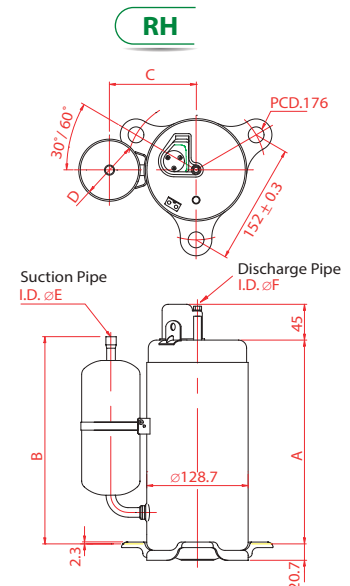

# Specifications of PH Model

Models	Capacity			Input		Normal Output		COP. (W/W)	EER. (Btu/hr*w)	Run Cap. (µF/VAC)	Weight (kgs.)	Oil Q'ty (cc.)
	W	Kcal/hr	Btu/hr	Watt	Amps	HP	KW.					

## High EER Models

### 4Legs

a) Electrical 50 Hz : 220 - 240 Volt : 1 Phase

PH33VPET	5,978	5,140	20,397	1,850	8.60	2.01	1.50	3.23	11.03	50/370	22.3	900
PH36VPET	6,466	5,560	22,062	2,015	9.30	2.15	1.60	3.21	10.95	55/400	22.3	900
PH39VPET	6,885	5,920	23,492	2,150	10.00	2.28	1.70	3.20	10.93	60/400	22.3	900
PH41VPJT	7,519	6,465	25,655	2,355	11.00	2.55	1.90	3.19	10.89	60/400	22.3	900

b) Electrical 60 Hz : 208 - 230 Volt : 1 Phase

PH33NPBT	7,118	6,120	24,287	2,200	10.80	2.01	1.50	3.24	11.04	35/370	21.8	900
PH36NPBT	7,734	6,650	26,388	2,390	11.60	2.15	1.60	3.24	11.04	35/370	22.1	900
PH39NPBT	8,257	7,100	28,173	2,560	12.60	2.28	1.70	3.23	11.01	35/370	22.1	900
PH41NPBT	8,930	7,678	30,469	2,850	13.40	2.55	1.90	3.13	10.69	45/420	22.1	900

### 3Legs

a) Electrical 50 Hz : 220 - 240 Volt : 1 Phase

PH33VTET	5,978	5,140	20,397	1,850	8.60	2.01	1.50	3.23	11.03	50/370	22.3	900
PH36VTET	6,466	5,560	22,062	2,015	9.30	2.15	1.60	3.21	10.95	55/400	22.3	900
PH39VTET	6,885	5,920	23,492	2,150	10.00	2.28	1.70	3.20	10.93	60/400	22.3	900
PH41VTJT	7,519	6,465	25,655	2,355	11.00	2.55	1.90	3.19	10.89	60/400	22.3	900

b) Electrical 60 Hz : 208 - 230 Volt : 1 Phase

PH33NTBT	7,118	6,120	24,287	2,200	10.80	2.01	1.50	3.23	11.04	35/370	21.8	900
PH36NTBT	7,734	6,650	26,388	2,390	11.60	2.15	1.60	3.23	11.04	35/370	22.1	900
PH39NTBT	8,257	7,100	28,173	2,560	12.60	2.28	1.70	3.22	11.01	35/370	22.1	900
PH41NTJT	8,930	7,678	30,469	2,850	13.40	2.55	1.90	3.13	10.69	45/420	22.1	1,100

## Premium High EER Models

### 4Legs

a) Electrical 50 Hz : 220 - 240 Volt : 1 Phase

PH36VPTT	6,685	5,748	22,809	1,970	9.00	2.15	1.60	3.39	11.58	60/450	22.5	670
PH36VPXT	6,685	5,748	22,809	2,000	9.30	2.15	1.60	3.34	11.40	55/400	22.4	900
PH39VPXT	7,170	6,165	24,464	2,145	10.00	2.30	1.70	3.34	11.41	60/450	22.8	900

## Compact Models

### 4Legs

a) Electrical 60 Hz : 208 - 230 Volt : 1 Phase

PH33NXBT	7,118	6,120	24,287	2,200	10.80	2.01	1.50	3.24	11.04	50/400	20.9	670
PH36NXBT	7,734	6,650	26,388	2,390	11.60	2.15	1.60	3.24	11.04	60/450	21.4	670

### 3Legs

a) Electrical 60 Hz : 208 - 230 Volt : 1 Phase

PH36NWBT	7,734	6,650	26,388	2,390	11.60	2.15	1.60	3.24	11.04	60/450	20.9	670
----------	-------	-------	--------	-------	-------	------	------	------	-------	--------	------	-----

- Note :**
1. Testing condition ASRE-T, for V code at 1 Phase 220 Volt 50Hz, for N code 1 Phase 220 Volt 60 Hz.
  2. All figures indicated are nominal value, for detailed specification, please contact sales representative.
  3. Oil type is NM56EP.

		Dimension (mm.)					
		A	B	D	E	F	H
PH (4Legs)	PH33-39VPET	316.3	308.9	74.0	16.0	9.6	52.0
	PH33-41NPBT						
	PH33-39VPXT						
PH (3Legs)	PH41VPJT	316.3	308.9	74.0	16.0	9.6	None
	PH33-39VTET						
	PH33-39NTBT						
	PH41VTJT						
PH41NTJT							
PH (4Legs) Compact	PH33-36NXBT	282.2	295.8	74.0	16.0	9.6	45.0
PH (3Legs) Compact	PH36NWBT	281.3	293.9	74.0	16.0	9.6	45.0

### PH (4Legs)

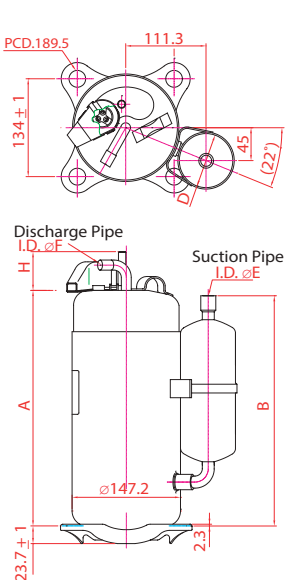

### PH (3Legs)

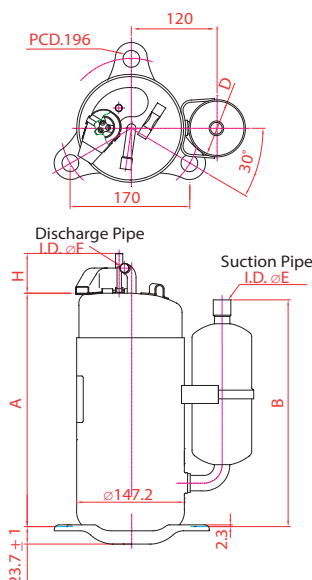

### PH Compact (4Legs)

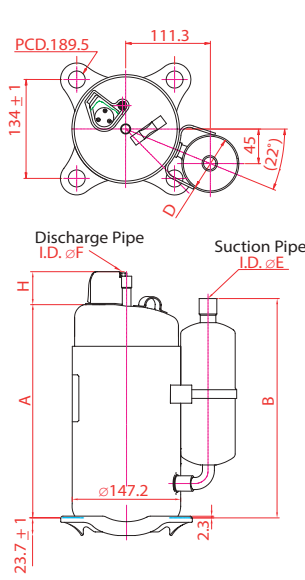

### PH Compact (3Legs)

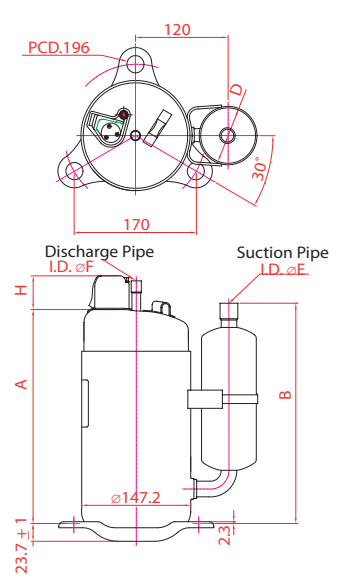

# Specifications of NH Model

Models	Capacity			Input		Normal Output		COP. (W/W)	EER. (Btu/hr*W)	Run Cap. (µF/VAC)	Weight (kgs.)	Oil Q'ty (cc.)
	W	Kcal/hr	Btu/hr	Watt	Amps	HP	KW.					

## High EER Models

a) Electrical 50 Hz : 220 - 240 Volt : 1 Phase

NH41VNHT	7,570	6,510	25,829	2,410	10.90	2.55	1.90	3.14	10.72	45/420	31.3	1,300
NH44VNHT	7,800	6,708	26,614	2,440	11.00	2.68	2.00	3.20	10.91	50/420	30.3	1,300
NH47VNHT	8,500	7,310	29,002	2,700	12.60	2.95	2.20	3.15	10.74	50/420	31.2	1,300
NH52VNHT	9,674	8,320	33,008	3,100	14.20	3.35	2.50	3.12	10.65	60/450	31.2	1,300
NH56VNHT	10,572	9,092	36,072	3,450	15.80	3.62	2.70	3.06	10.46	60/450	32.2	1,300

b) Electrical 60 Hz : 208 - 230 Volt : 1 Phase

NH41NAHT	9,405	8,088	32,090	2,894	12.90	2.55	1.90	3.25	11.09	50/400	32.2	1,300
NH44NAHT	9,884	8,500	33,724	3,095	14.10	2.68	2.00	3.19	10.90	55/380	31.8	1,300
NH47NAHT	10,570	9,090	36,065	3,340	15.10	2.95	2.20	3.16	10.80	60/450	31.8	1,300
NH52NAHT	11,692	10,055	39,893	3,710	16.81	3.35	2.50	3.15	10.75	65/400	31.8	1,300
NH56NAHT	12,860	11,060	43,878	4,100	18.68	3.62	2.70	3.14	10.70	65/400	32.2	1,300

c) Electrical 50 Hz : 380 - 415 Volt : 3 Phases

NH41YDHT	7,450	6,407	25,419	2,310	3.95	2.55	1.90	3.23	11.00	-	30.3	1,300
NH44YDHT	8,100	6,966	27,637	2,510	4.30	2.68	2.00	3.23	11.01	-	29.3	1,300
NH47YDHT	8,650	7,439	29,514	2,680	4.60	2.95	2.20	3.23	11.01	-	29.3	1,300
NH52YDHT	9,710	8,351	33,131	3,010	5.30	3.35	2.50	3.23	11.01	-	30.3	1,300
NH56YDHT	10,650	9,159	36,338	3,300	5.85	3.62	2.70	3.23	11.01	-	32.2	1,300

d) Electrical 50/60 Hz : 200/200-230 Volt : 3 Phases

NH38TKAT	6,744	5,801	23,011	2,210	7.50	2.28	1.70	3.05	10.41	-	29.2	1,300
NH41TKAT	7,267	6,250	24,795	2,420	8.00	2.55	1.90	3.00	10.25	-	29.2	1,300
NH44TKAT	7,919	6,810	27,020	2,550	8.80	2.68	2.00	3.11	10.60	-	28.5	1,600
NH47TKAT	8,372	7,200	28,565	2,790	10.00	2.95	2.20	3.00	10.24	-	28.2	1,300
NH52TKAT	9,442	8,120	32,216	3,160	10.90	3.35	2.50	2.99	10.19	-	29.3	1,300
NH56TKAT	10,291	8,850	35,113	3,420	11.60	3.62	2.70	3.01	10.27	-	31.0	1,300

## Premium High EER Models

a) Electrical 50 Hz : 220 - 240 Volt : 1 Phase

NH41VNWT	7,529	6,475	25,689	2,216	10.20	2.55	1.90	3.40	11.59	45/420	30.2	1,300
NH44VNWT	8,270	7,111	28,217	2,475	11.60	2.80	2.10	3.34	11.40	50/420	30.7	1,300
NH47VNWT	8,800	7,568	30,026	2,634	12.20	2.95	2.20	3.34	11.40	55/400	30.7	1,300
NH52VNWT	9,850	8,471	33,608	3,000	13.90	3.35	2.50	3.28	11.20	55/400	30.7	1,300

## Ultra Tough Models

a) Electrical 50 Hz : 220 - 240 Volt : 1 Phase

NH41VXBT	7,570	6,510	25,829	2,410	10.90	2.55	1.90	3.14	10.72	45/420	31.3	1,300
NH44VXBT	8,100	6,966	27,637	2,550	11.80	2.68	2.00	3.18	10.84	50/420	31.2	1,300
NH47VXBT	8,650	7,439	29,514	2,750	12.60	2.95	2.20	3.15	10.73	50/420	31.2	1,300
NH52VXBT	9,674	8,320	33,008	3,100	14.20	3.35	2.50	3.12	10.65	60/450	31.2	1,300
NH56VXBT	10,572	9,092	36,072	3,450	15.80	3.62	2.70	3.06	10.47	60/450	31.2	1,300

b) Electrical 60 Hz : 208 - 230 Volt : 1 Phase

NH44NXBT	9,884	8,500	33,724	3,095	14.10	2.68	2.00	3.19	10.90	55/380	31.8	1,300
NH47NXBT	10,570	9,090	36,065	3,340	15.10	2.95	2.20	3.16	10.80	60/450	31.8	1,300
NH52NXBT	11,692	10,055	39,893	3,710	16.81	3.35	2.50	3.15	10.75	65/400	31.8	1,300
NH56NXBT	13,050	11,223	44,527	4,200	18.68	3.62	2.70	3.11	10.60	65/400	32.2	1,300

c) Electrical 50 Hz : 380 - 415 Volt : 3 Phases

NH41YXCT	7,450	6,407	25,419	2,310	3.95	2.55	1.90	3.23	11.00	-	30.3	1,300
NH47YXCT	8,650	7,439	29,514	2,680	4.60	2.95	2.20	3.23	11.01	-	29.3	1,300
NH52YXCT	9,710	8,351	33,131	3,010	5.30	3.35	2.50	3.23	11.01	-	30.6	1,300
NH56YXCT	10,650	9,159	36,338	3,300	5.85	3.62	2.70	3.23	11.01	-	31.3	1,300

- Note :**
1. Testing condition ASRE-T, for V code at 1 Phase 220 Volt 50 Hz, for N code 1 Phase 220 Volt 60 Hz, for Y code at 3 Phases 400 Volt 50 Hz.
  2. All figures indicated are nominal value, for detailed specification, please contact sales representative.
  3. Oil type is NM56EP.

	Dimension (mm.)					
	A	B	D	E	F	H
NH41-47VNHT NH44-47NXBT NH41-47NAHT NH38-47TKAT	341.3	392.3	74.0	16.0	9.6	52.0
NH41-47YDHT NH41-47YXCT	341.3	392.3	74.0	16.0	9.6	None
NH52-56VNHT NH44-52VNWT NH41-56VXBT NH52-56NAHT NH52-56NXBT NH52-56TKAT	341.3	392.3	74.0	19.1	9.6	52.0
NH52-56YDHT NH52-56YXCT	341.3	392.3	74.0	19.1	9.6	None
NH41VNWT	341.3	392.3	74.0	19.1	9.5	None

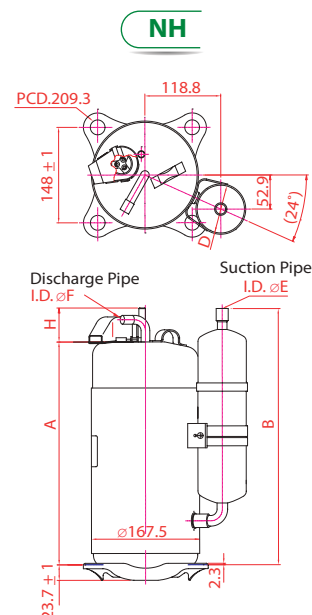

# Operation Standards and Limits of R-22 Compressor RH, PH, NH Model

Models	RH	PH	NH
<b>Compressor</b>			
Type	Rolling Piston Type Rotary		
Displacement (cc/rev.)	13.0 ~ 31.3	28.1 ~ 44.1	28.1 ~ 38.8, 41.8 ~ 56.9
Refrigerant type	R-22		
<b>Pressure</b>			
Condensing	1.03 ~ 2.60 MPaG (149.3 ~ 377 psiG)		
Evaporating	0.26 ~ 0.69 MPaG (37.7 ~ 100 psiG)		
Compression Ratio	6 or less	8 or less (See Note 1)	
Abnormal Rise in pressure	3.92 MPaG ( 568.5psiG) or less		
<b>Temperature</b>			
Condensing	28°C ~ 65°C (82.4°F ~ 149°F)		
Evaporating	-10°C ~ 15°C (14°F ~ 59°F)		
Discharged Gas (max)	120°C (248°F), In case of Heat pump or De-humidifier, this limit is 115°C (239°F) (See Note 2)		
Suction Gas (max)	must be over 0°C (No liquid back) (See Note 2)		
Discharged gas 's superheat	20°C or more		
Outdoor Ambient Temp.	Air cond : 20°C ~ 43°C (68°F ~ 109.4°F) Heat Pump : -10°C ~ 43°C (14°F ~ 109.4°F)		
<b>Electrical</b>			
Supply voltage during operation	Rated voltage ±10%		
Starting voltage	Minimum 80% of rated voltage (at 1.01MPa balancing pressure). In case of 208 - 230 V Rated Voltage (N-code compressor), the starting voltage shall be 85% or more. This shall be measured at compressor terminal at in stance of start		
Reverse phase (rotation)	Compressor is not designed to run reverse phase		
Frequency range	Rated Frequency ± 2%		
<b>ON/OFF</b>			
ON/OFF Frequency	Less than 170,000 cycles		
ON/OFF Cycle	The ON/OFF cycle shall be a maximum of 10 time/hour. OFF time shall be the time until the high side pressure reach to balance pressure (more than 3 min)		
Pipe Stress	3.5 kg/mm <sup>2</sup> or less at start and stop condition (1.8 kg/mm <sup>2</sup> during operation)		
<b>Refrigerant Circuit</b>			
Maximum Refrigerant Charge	See in General Spec		
Evacuation level	Degree of vaccum equivalent to about 133 Pa (abs) (1.0 mmHg)		
Piping length between indoor and outdoor units	Max. 15 m. for RH130-RH174 Max. 20 m. for RH189-RH 313	Max. 30 m. (for Ultra Tough Model, Max. 50 m.) (See also Note 3)	
Elevation between indoor and outdoor units	Max. 7 m. for RH130-RH174 Max. 15 m. for RH189-RH 313	Max. 20 m. (See also Note 3)	
Piping vibration	Maximum 0.8 mm.		
Inclination of compressor	Within 5°		

- Note :**
1. High compression ratio test; C.T./E.T. = 62/-12°C ; has been performed already.
  2. The temperature must be lower than this critical value even the unit has been using for many years.
  3. These Piping Length and Elevation for all series are based on pipe size following this; Liquid : Ø 9.52 mm. (3/8") Gas : Ø 15.88 mm. (5/8")



# Ultra Tropical Compressor Information / Specifications of Ultra Tropical Compressor (R-410A)

These ultra tropical rotary compressors which are suitably invented for high ambient zone, are prized for their extremely high reliable mechanism bringing to longer product life-time, powerful motor with compact size and light weight. All of these ultra tropical advanced features are resulting from our tropical market insight and our expert technology owned by MITSUBISHI ELECTRIC.

- **Higher operating ambient temperature**

Up to 55°C (CT 68°C & CT 75°C for Transient ) for R-410A

Up to 52°C (CT 68°C) for R-32

Up to 55°C (CT 71°C & CT 76°C for Transient ) for R-22

- **Higher operating pressure**

Up to 5.00 MPaG (725.2 psiG) for R-410A

Up to 4.56 MPaG (661.4 psiG) for R-32

Up to 3.22 MPaG (468.5 psiG) for R-22

These ultra tropical compressors can superbly perform even in the very high temperature such as desert area. The well designed compressors are an ideal solution for every air-conditioning system in the world toughest tropical zone.

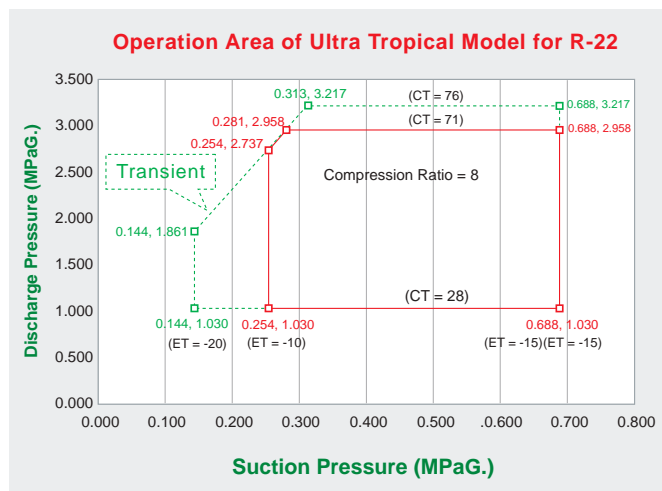

- **Mechanical Part Strengthening**

During high ambient temperature operation, parts of compressor contacting together are corrosion easily. With Mitsubishi technology, all critical parts are treated with specialized material and specific hardening process causing compressor to be more durable.

- **High Torque Motor**

Get greatest efficiency from the high performance motor with our ultra tropical compressor, which torque optimized for higher high temperature condition.

Models	Capacity			Input		Normal Output		COP. (W/W)	EER. (Btu/hr*w)	Run Cap. (µF/VAC)	Weight (kgs.)	Oil Q'ty (cc.)
	W	Kcal/hr	Btu/hr	Watt	Amps	HP	KW.					
<b>Ultra Tropical R-410A</b>												
<b>RNT</b>												
a) Electrical 50 Hz : 220 - 240 Volt : 1 Phase												
RNT174V--MT*	4,170	3,586	14,228	1,390	6.40	1.61	1.20	3.00	10.24	40/370	15.3	440
RNT189V--MT*	4,400	3,784	15,013	1,550	7.20	1.74	1.30	2.84	9.69	40/370	15.3	440
RNT196V--MT*	4,860	4,180	16,582	1,640	7.80	1.74	1.30	2.96	10.11	50/370	15.7	440
RNT207V--MT*	5,380	4,627	18,357	1,720	8.10	1.88	1.40	3.13	10.67	45/420	14.9	440
b) Electrical 60 Hz : 208 - 230 Volt : 1 Phase												
RNT135N--MT	4,000	3,440	13,648	1,380	7.00	1.57	1.17	2.90	9.89	45/400	16.4	420
RNT154NBAMT	4,750	4,085	16,207	1,540	7.10	2.00	1.49	3.08	10.52	45/370	17.1	420
RNT174NAAMT	5,220	4,489	17,811	1,710	7.80	2.00	1.49	3.05	10.42	45/370	17.1	420
RNT196N--MT*	6,050	5,203	20,643	1,930	8.80	2.23	1.66	3.13	10.70	45/370	16.5	440
RNT207NBBMT	6,300	5,418	21,496	2,020	9.30	2.37	1.77	3.12	10.64	45/370	16.5	440
RNT220N--MT*	6,650	5,719	22,690	2,130	9.90	2.49	1.86	3.12	10.65	55/400	15.8	440
<b>PNT</b>												
a) Electrical 50 Hz : 220 - 240 Volt : 1 Phase												
PNT24V--MT*	6,220	5,349	21,223	2,040	9.40	2.41	1.80	3.05	10.40	60/420	23.7	520
PNT25V--MT*	6,400	5,504	21,837	2,100	9.60	2.41	1.80	3.05	10.40	60/420	23.7	520
PNT27V--MT*	6,700	5,762	22,860	2,260	10.30	2.55	1.90	2.96	10.12	60/420	24.1	670
PNT33V--MT*	8,490	7,301	28,968	2,920	13.30	3.08	2.30	2.91	9.92	65/420	24.5	900
b) Electrical 60 Hz : 208 - 230 Volt : 1 Phase												
PNT23N--MT*	7,120	6,123	24,293	2,355	10.70	2.68	2.00	3.02	10.32	50/400	24.1	670
PNT24NAAMT	7,330	6,304	25,010	2,410	10.2	2.68	2.00	3.04	10.38	50/400	22.4	670
PNT29N--MT	9,100	7,826	31,049	3,140	13.30	3.49	2.60	2.90	9.89	55/400	24.5	900
<b>NNT</b>												
a) Electrical 50 Hz : 220 - 240 Volt : 1 Phase												
NNT33VAAMT	8,360	7,190	28,524	2,850	13.20	3.08	2.30	2.93	10.01	55/420	31.9	1,300
NNT37V--MT*	9,350	8,041	31,902	3,220	15.00	3.75	2.80	2.90	9.91	60/420	31.6	1,300
NNT40V--MT*	10,250	8,815	34,973	3,500	16.30	4.02	3.00	2.93	9.99	60/420	31.6	1,300
NNT44V--MT*	11,300	9,718	38,556	3,870	18.80	4.43	3.30	2.92	9.96	65/440	31.6	1,300
b) Electrical 50 Hz : 380-415 Volt : 3 Phases												
NNT37Y--MT*	9,350	8,041	31,902	3,110	5.30	3.62	2.70	3.01	10.26	-	31.0	1,300
NNT40Y--MT*	10,250	8,815	34,973	3,410	5.80	3.89	2.90	3.01	10.26	-	31.9	1,300

**Note :** 1. Testing condition ARI for RVT, PVT; ASRE-T for RNT, PNT, NNT, RHT, PHT, NHT, NHJ; for V code at 1 Phase 220 Volt 50 Hz, for N code at 1 Phase 220 Volt 60 Hz.  
 2. Oil type EV50S for RNT, PNT, NNT; FW68S for RVT, PVT; NM56EP for RHT, PHT, NHT, NHJ  
 3. For full model name, please contact sales representative



# Specifications of Ultra Tropical Compressor (R-32, R-22)

Models	Capacity			Input		Normal Output		COP. (W/W)	EER. (Btu/hr*w)	Run Cap. (µF/VAC)	Weight (kgs.)	Oil Q'ty (cc.)
	W	Kcal/hr	Btu/hr	Watt	Amps	HP	KW.					
<b>Ultra Tropical R-32</b>												
<b>RVT</b>												
a) Electrical 50 Hz : 220 - 240 Volt : 1 Phase												
RVT125VFDMT	3,070	2,640	10,475	1,110	5.10	1.21	0.90	2.77	9.44	30/370	15.9	520
RVT135VFDMT	3,400	2,924	11,601	1,180	5.50	1.21	0.90	2.88	9.83	30/370	15.7	520
RVT174VFEMT	4,500	3,870	15,354	1,520	7.10	1.74	1.30	2.96	10.10	40/370	16.4	520
RVT189V--MT*	4,730	4,068	16,139	1,680	8.00	1.88	1.40	2.82	9.61	45/370	16.2	520
RVT220VBBMT	5,590	4,807	19,073	1,950	9.00	1.88	1.40	2.87	9.78	50/400	16.9	520
<b>PVT</b>												
PVT23V--MT*	5,940	5,108	20,267	2,160	10.00	2.41	1.80	2.75	9.38	55/400	24.2	900
PVT25V--MT*	6,380	5,487	21,769	2,260	9.60	2.55	1.90	2.82	9.63	60/420	24.4	900
<b>Ultra Tropical R-22</b>												
<b>RHT</b>												
a) Electrical 50 Hz : 220 - 240 Volt : 1 Phase												
RHT313VADT	5,580	4,798	19,039	1,835	8.50	1.74	1.30	3.04	10.38	50/400	15.7	520
b) Electrical 60 Hz : 208 - 230 Volt : 1 Phase												
RHT277NAAT	5,880	5,056	20,063	1,840	8.55	1.74	1.30	3.20	10.90	40/370	15.4	520
<b>PHT</b>												
a) Electrical 50 Hz : 220 - 240 Volt : 1 Phase												
<b>4Legs</b>												
PHT33VXET	6,000	5,159	20,472	1,880	8.80	2.01	1.50	3.19	10.89	60/450	20.9	670
PHT41VBAT	7,519	6,465	25,655	2,355	11.00	2.55	1.90	3.19	10.89	60/450	22.7	900
<b>3Legs</b>												
PHT33VWET	6,000	5,159	20,472	1,880	8.80	2.01	1.50	3.19	10.89	60/450	20.9	670
PHT41VDAT	7,519	6,465	25,655	2,355	11.00	2.55	1.90	3.19	10.89	60/450	22.7	900
b) Electrical 60 Hz : 208 - 230 Volt : 1 Phase												
<b>4Legs</b>												
PHT33NXBT	7,118	6,120	24,287	2,200	10.80	2.01	1.50	3.24	11.04	50/400	20.9	670
PHT36NXBT	7,734	6,650	26,388	2,390	11.60	2.15	1.60	3.24	11.04	60/450	20.9	670
<b>3Legs</b>												
PHT33NWBT	7,118	6,120	24,287	2,200	10.80	2.01	1.50	3.24	11.04	50/400	20.9	670
PHT36NWBT	7,734	6,650	26,388	2,390	11.60	2.15	1.60	3.24	11.04	60/450	20.9	670
<b>NHT</b>												
a) Electrical 50 Hz : 220 - 240 Volt : 1 Phase												
NHT41VBAT	7,640	6,569	26,068	2,380	11.20	2.55	1.90	3.21	10.95	55/420	31.2	1,300
NHT44VBAT	7,850	6,750	26,784	2,490	11.60	2.68	2.00	3.15	10.76	55/420	31.2	1,300
NHT47VBAT	8,400	7,223	28,661	2,700	13.00	2.95	2.20	3.11	10.62	60/450	31.2	1,300
NHT52VBAT	9,320	8,014	31,800	2,970	14.10	3.35	2.50	3.14	10.71	60/450	31.2	1,300
b) Electrical 60 Hz : 208 - 230 Volt : 1 Phase												
NHT44NBBT	9,800	8,426	33,438	3,060	14.10	2.68	2.00	3.20	10.93	55/420	31.2	1,300
<b>Ultra Tropical Liquid Injection R-22</b>												
a) Electrical 50 Hz : 220 - 240 Volt : 1 Phase												
NHJ56VNHT	10,572	9,090	36,072	3,450	15.80	3.62	2.70	3.06	10.46	60/450	32.2	1,300
b) Electrical 60 Hz : 208 - 230 Volt : 1 Phase												
NHJ47NAHT	10,570	9,090	36,065	3,340	15.10	2.95	2.20	3.16	10.80	60/450	32.2	1,300
NHJ52NAHT	11,692	10,055	39,893	3,710	16.81	3.35	2.50	3.15	10.75	65/400	32.2	1,300
NHJ56NAHT	12,860	11,060	43,878	4,100	18.68	3.62	2.70	3.14	10.70	65/400	32.2	1,300

**Note :** 1. Testing condition ARI for RVT, PVT; ASRE-T for RNT, PNT, NNT, RHT, PHT, NHT, NHJ; for V code at 1 Phase 220 Volt 50 Hz, for N code at 1 Phase 220 Volt 60 Hz.  
 2. Oil type EV50S for RNT, PNT, NNT; FW68S for RVT, PVT; NMS56EP for RHT, PHT, NHT, NHJ  
 3. For full model name, please contact sales representative



# Specifications of Ultra Tropical Compressor (R-410A, R-32, R-22)

		Dimension (mm.)				
		A	B	D	E	F
RNT	RNT207V	262.2	287.5	78.0	12.7	9.6
	RNT174-189V	264.7	287.5	78.0	12.7	9.6
	RNT174-220N, RNT196V	268.2	287.5	78.0	12.7	9.6
	RNT135-154N	276.7	287.5	78.0	12.7	9.6
PNT	PNT23N	316.3	308.9	78.0	16.0	9.6
	PNT24N	292.3	296.9	78.0	16.0	9.6
	PNT24-33V, PNT29N	317.6	308.9	78.0	16.0	9.6
NNT	NNT33	342.8	393.6	78.0	16.0	9.6
	NNT37-44	342.8	393.6	78.0	19.1	9.6
RVT	RVT125-135	256.2	260.5	78.0	12.7	9.6
	RVT174	264.7	287.5	78.0	12.7	9.6
	RVT220	276.7	289.5	78.0	16.0	9.6
PVT	PVT23-25	317.6	308.9	78.0	16.0	9.6
RHT	RHT313VADT	261.2	282.5	74.0	12.7	9.7
	RHT277NAAT	256.2	260.5	74.0	12.7	8.0
PHT (4Legs)	PHT33VXET	305.9	295.8	74.0	16.0	9.6
	PHT33-36NXBT	340.0	308.9	74.0	16.0	9.5
	PHT41VBAT					
PHT (3Legs)	PHT33VWET	303.0	293.9	74.0	16.0	9.6
	PHT33-36NWBT	340.0	308.9	74.0	16.0	9.6
	PHT41VDAT					
NHT	NHT41-47VBAT	341.3	392.3	74.0	16.0	9.6
	NHT44NBBT					
	NHT41-47YBAT	341.3	392.3	74.0	19.1	9.6
	NHT52VBAT					
NHJ	NHT52-56YBAT	341.3	392.3	74.0	16.0	9.6
	NHJ47 NAHT					
	NHJ52-56NAHT	341.3	392.3	74.0	19.1	9.6
	NHJ56VNHT					

## RHT/RNT

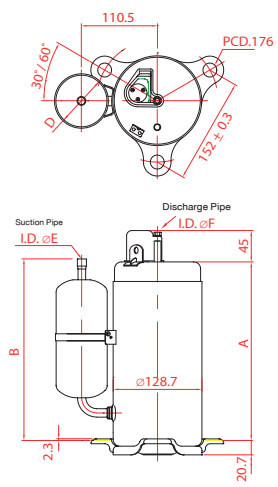

<< Drawing from Page 25

## RVT

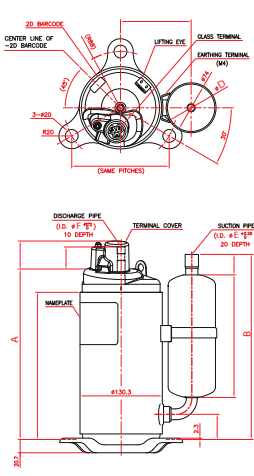

## PVT

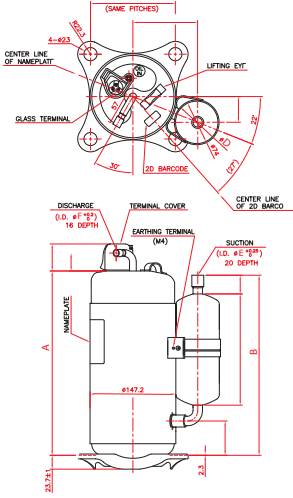

## PHT (4Legs)/PNT24-33V

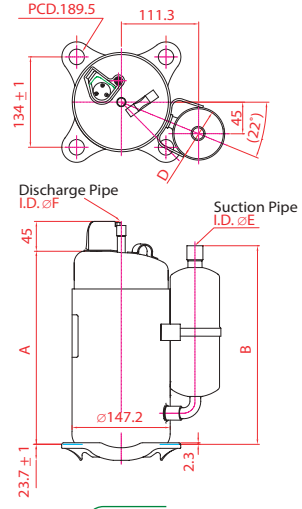

## PHT (3Legs)/PNT23N

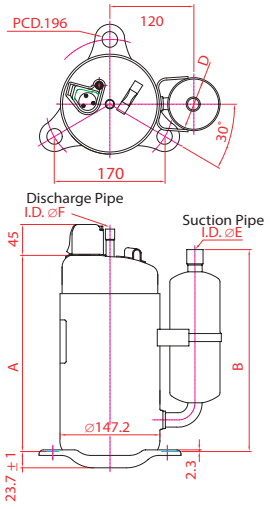

## NHT/NNT

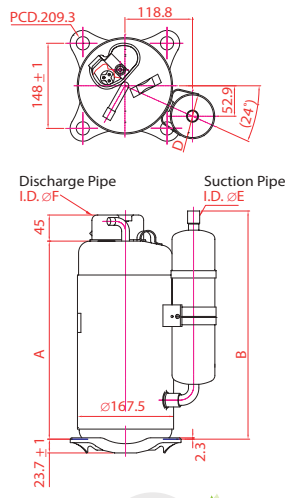

## NHJ

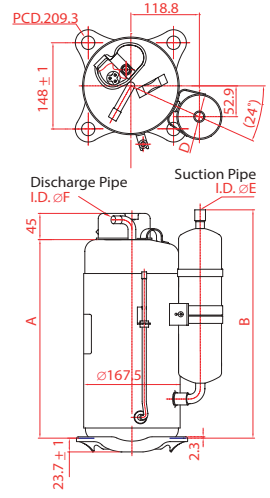

# Operation Standards and Limits of R-410A, R-32, R-22 Compressor Ultra Tropical Model

Models	RNT	PNT	NNT	RVT	PVT	RHT	PHT	NHT/NHJ
<b>Compressor</b>								
Type	Rolling Piston Type Rotary							
Displacement (cc/rev.)	17.4~22.0	24.0~33.0	37.0~44.0	12.5~22.0	23.0~25.0	27.7~31.3	33.0~41.0	41.0~56.0
Refrigerant type	R-410A			R-32		R-22		
<b>Pressure</b>								
Condensing	Normal Range : 1.68~4.30 MPaG (243.7~623.7 psiG) Maximum limit (transient): 5.00 MPaG (752 psiG)			0.21~5.0 MPaG (30.5~725.2 psiG)		1.69~4.15 MPaG (245.1~602 psiG)		Normal Range 1.03~2.60 MPaG (149.3~377 psiG) Tropical Range 1.03~2.95 MPaG (149.3~427.8 psiG) Maximum Limit (transient) 3.23 MPaG (468.4 psiG)
Evaporating	0.47~1.15 MPaG (68.2~166.8 psiG)			0.21~1.62 MPaG (30.5~236.4 psiG)		0.47~1.15 MPaG (68.1~166.8 psiG)		0.26~0.69 MPaG (37.7~100.1 psiG)
Compression Ratio	6 or less			9 or less		8 or less		6 or less 8 or less (See Note 1)
Abnormal Rise in pressure	5.88 MPaG (852.8 psiG) or less			5.88 MPaG (852.8 psiG) or less		5.88 MPaG (852.8 psiG) or less		3.29 MPaG (568 psiG) or less
<b>Temperature</b>								
Condensing	Normal Range : 28°C~68°C (82.4°F~154.4°F) Maximum limit (transient): 75°C (167°F)			-27°C~65°C (16.6°F~149°F)		-28°C~65°C (82.4°F~149°F)		Normal Range 28°C~65°C (82.4°F~149°F) Tropical Range 28°C~71°C (82.4°F~160°F) Maximum Limit (transient) 76°C (169°F)
Evaporating	10°C~15°C (14°F~59°F)			-27°C~26°C (16.6°F~78.8°F)		-10°C~15°C (14°F~59°F)		-10°C~15°C (14°F~59°F)
Discharged Gas (max)	115°C (239°F)			125°C (257°F), in case of Heat pump or De-humidifier, this limit is 115°C (239°F) See Note 2)		120°C (248°F) (See Note 2)		
Suction Gas (max)	must be over 0°C (No liquid back) See Note 2)							
Discharged gas's superheat	20°C or more							
Outdoor Ambient Temp.	Air Cond : 20°C~55°C (68°F~131°F), Heat Pump : -10°C~55°C (14°F~131°F)		Air Cond : 20°C~52°C (68°F~125.6°F), Heat Pump : -10°C~52°C (14°F~125.6°F)		Air Cond : 20°C~43°C (68°F~109.4°F), Heat Pump : -10°C~43°C (14°F~109.4°F)		Air Cond : 20°C~55°C (68°F~131°F), Heat Pump : -10°C~55°C (14°F~131°F)	
<b>Electrical</b>								
Supply voltage during operation	Normal Range Rated voltage -15%, ± 10% in 220-240V (V-code) and Rated Voltage ±10% in 208-230V (N-code) Tropical Range Rated voltage ± 10% in 220-240V (V-code) and Rated Voltage -5% ±10% in 208-230V (N-code)							
Starting voltage	Minimum 70% of Rated voltage (at 1.01 MPa balancing pressure) In case of 208-230 V Rated Volted (N-code compressor), the starting voltage shall be 75% or more. This shall be measured at compressor terminal at instance of start.							
Reverse phase (rotation)	Compressor is not designed to run reverse phase.							
Frequency range	Rated Frequency ± 2%							
<b>ON/OFF</b>								
ON/OFF Frequency	Less than 170,000 cycles							
ON/OFF Cycle	The ON/OFF cycle shall be a maximum of 10 time/hour. OFF time shall be the time until							
<b>Refrigerant Circuit</b>								
Maximum Refrigerant Charge	See in General Spec							
Evacuation level	Degree of vaccum equivalent to about 133 pa (abs) (1.0mmHg)							
Piping length between indoor and outdoor units	Max. 20 m	Max. 30 m (See also Note 3)		Max. 20 m	Max. 30 m (See also Note 3)		Max. 20 m	Max. 30 m (See also Note 3)
Elevation between indoor and outdoor units	Max. 15 m	Max. 20 m (See also Note 3)		Max. 15 m	Max. 20 m (See also Note 3)		Max. 15 m	Max. 20 m (See also Note 3)
Piping vibration	Maximum 0.8 mm.							
Inclination of compressor	within 5°							

- Note :**
1. High compression ratio test ; C.T./E.T. = 62/-12°C ; has been performed already.
  2. The temperature must be lower than this critical value even the unit has been using for many years.
  3. These Piping Length and Elevation for all series are based on pipe size following this ; Liquid : Ø 9.52 mm. (3/8") Gas : Ø 15.88 mm. (5/8")





**SIAM COMPRESSOR  
INDUSTRY CO., LTD.**

**Siam Compressor Industry Co., Ltd.**

**Head Office & Factory :**

Laem Chabang Industrial Estate 87/10 Moo 2,  
Sukhumvit Road, Sriracha, Chonburi 20230, Thailand  
Tel. +66 (0) 38 490 900 to 912  
Fax. +66 (0) 38 490 917

**Website : [www.siamcompressor.com](http://www.siamcompressor.com)**

**Marketing Office :**

979/108 - 110, 32<sup>nd</sup> Floor S.M. Tower Phaholyothin Road,  
Samsennai, Phayathai, Bangkok 10400, Thailand  
Tel. +66 (0) 2298 0371 to 377  
Fax. +66 (0) 2298 0411 to 2