



REFRIGERATOR COMPRESSORS



Index

ECOFRIENDLY

LOCATION

WHY US?

PRODUCTION SITE

QUALITY CERTIFICATIONS

SPECIFICATIONS

MINI-L MODELS

MIDI MODELS

VNTZ MODELS

OTHER DETAILS

WIRING DIAGRAMS

OTHER DETAILS

APPLICATION SPECIFICATIONS - NOTIFICATIONS

HEAVY DUTY CARTON BOX

WOODEN PALLET TYPE

TEST CONDITIONS



Ecofriendly

Energy efficient products,
less electricity consumption and
lower CO₂ footprint product



Logistic advantage from Eskişehir to

Lead time 1 week for Turkey and
2 weeks for EU region and North Africa*

** For customers having a purchase agreement*



Why us?



WHY DO DOZENS OF MANUFACTURER CHOOSE TEE?

- Production over 4 decades
- Being close to the customer, lets us invent the technology
- Our production process focuses on consumer needs
- TEE is with you all the time and everywhere



TEE Compressor Plant is a leading compressor manufacturer with experienced R&D and advanced manufacturing technologies since 1975. The Company is the first and still the only hermetic compressor manufacturer in Turkey.

Today, TEE Compressor Plant continues developing environment-friendly, hi-tech, efficient and compact hermetic reciprocating compressor technologies, providing reliable and high quality products to our worldwide customers. Over the years, the production capacities have continuously been enlarged. We produced more than 55 million compressors until today and they are still working all over the world.

In order to make a significant contribution to environmental protection, highly efficient

and environment-friendly natural refrigerant R600a used compressors have been produced. TEE Compressor Plant applies a Quality Management System according to ISO 9001 since 1993. Also our compressor products have passed certifications by various authorities, e.g. TSE, TUV, VDE.

Our focus is to develop and manufacture environment-friendly, reliable and affordable products by implementing state-of-the-art technologies and deliver after sales service to exceed customer expectations.

TEE creates and supports high efficient, silent and reliable solutions at household hermetic reciprocating compressor appliances.



- TEE considers your needs and develops latest technologies.

TEE provides a great product range with both conventional and inverter compressor technologies that widely cover from small sized to large sized household refrigerator systems. This variety provides the optimal solutions to the customers.

- TEE cares about the world and the future.

TEE Inverter Compressor technology adjusts the compressor speed according to cooling system conditions. During low cooling requirements, this provides to work with very low speed as a sleep mode instead of stop-and-go mode; that increases the energy losses. This technology increases the total system efficiency by enabling more energy-efficient applications.

- TEE produces the energy efficient products for you.

TEE provides the high efficient hermetic reciprocating compressor with a COP of 2.00 at ASHRAE conditions.*

- TEE is with you all the time and everywhere.

TEE aims to give you the best customer support from design stage to after sales service in order to provide the optimal solution about compressor performance.

*At ASHRAE conditions.

Quality Certifications





Putting client into center; making projects together



Precise Production Measurement

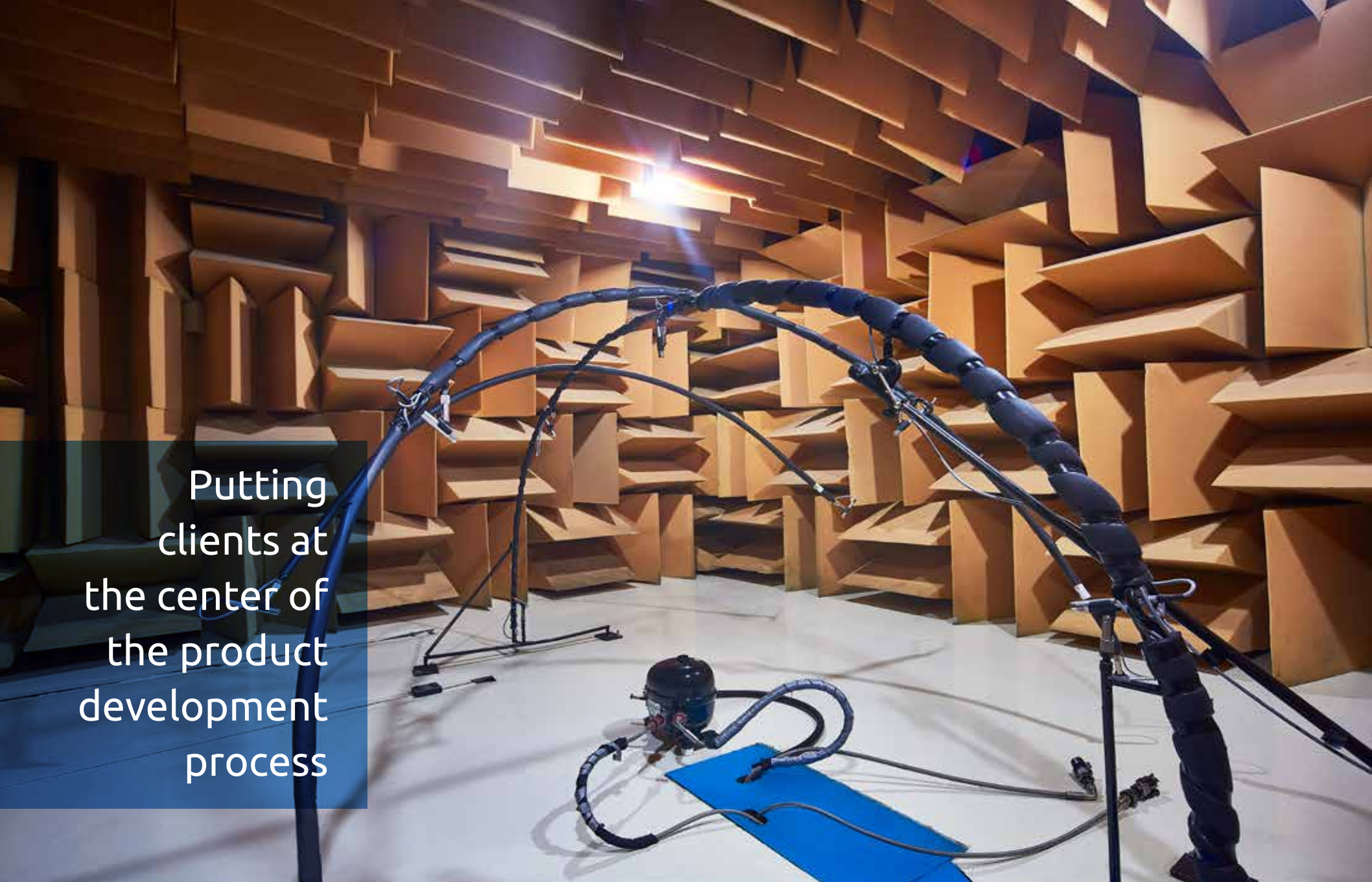

Putting clients at the center of the product development process



WORKING WITHOUT INVENTORY



EVERYTHING JUST IN TIME

MINI-L MODELS

SERIES	BM NO	DIMENSIONS (mm.)	
		A	B
NTZ145	ALL	158	59

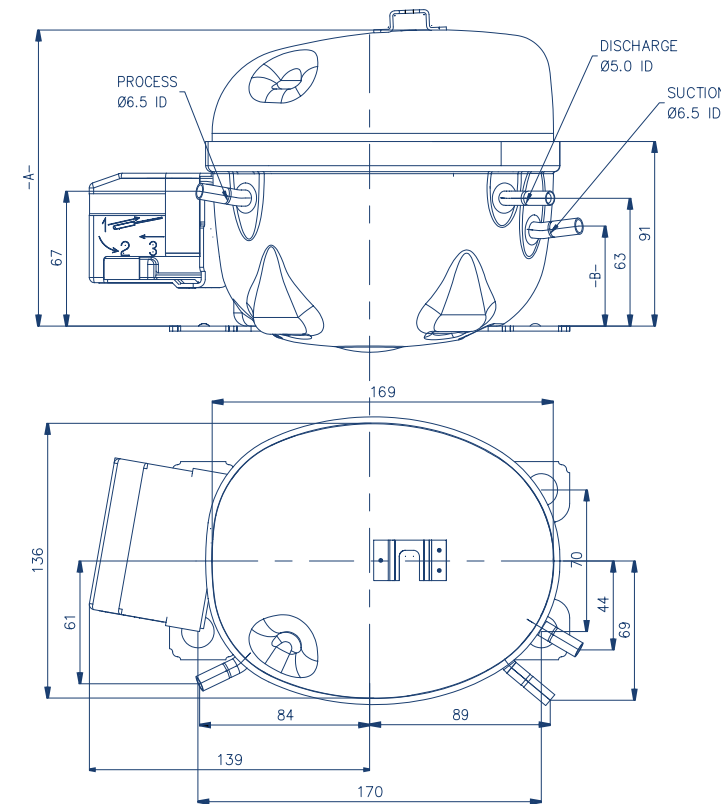

Refrigerant	Application	Model	B/M No	Displacement	Net Wt.	Oil Charge	Motor Type	Voltage and Frequency	Refrigerating Capacity								COP
									Ashrae							Cecomaf	
									-35°C	-30°C	-25°C	-23,3°C	-20°C	-15°C	-10°C	-25°C	-23,3°C
									Kcal/h	Kcal/h	Kcal/h	Kcal/h	Kcal/h	Kcal/h	Kcal/h	W	W/W
R600a	LBP	NTZ 145 MT	391-05	9,85	7,5	160	1	1	81	106	137	146	175	224	281	128	1,65

*All models are certified by VDE or TUV and TSE.

MIDI MODELS

SERIES	BM NO	DIMENSIONS (mm.)
		A
NTU120,150,170	ALL	173

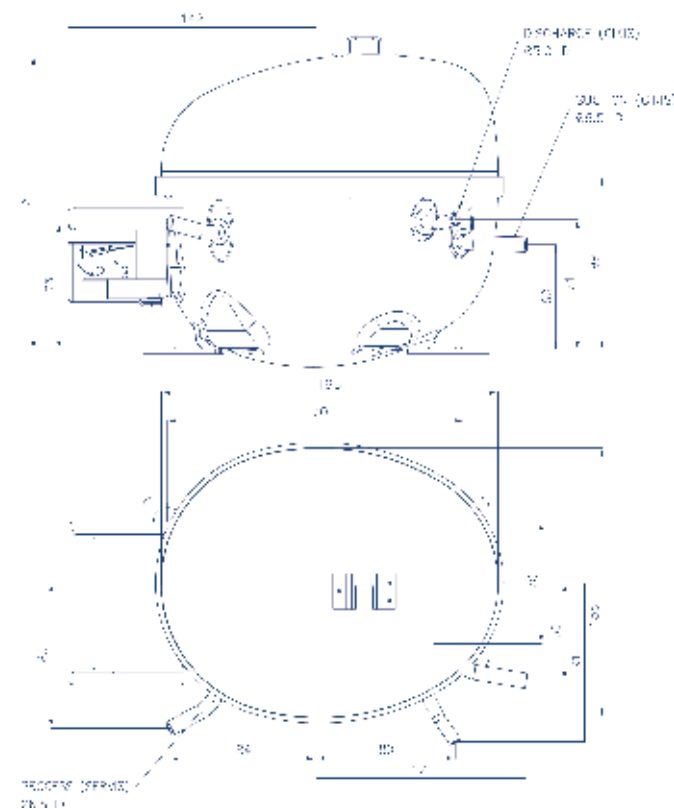

Refrigerant	Application	Model	B/M No	Wire	Displacement	Net Wt.	Oil Charge	Motor Type	Voltage and Frequency	Refrigerating Capacity							COP	
										Ashrae							Cecomaf	Ashrae
										-35°C	-30°C	-25°C	-23,3°C	-20°C	-15°C	-10°C	-25°C	-23,3°C
										Kcal/h	Kcal/h	Kcal/h	Kcal/h	Kcal/h	Kcal/h	Kcal/h	W	W/W
R600a LBP		NTU 120 MT	232-00 232-16 232-05	Cu/Cu Al/Al Al/Al	8,61	9,0 8,1 7,9	175	1	1	64	84	109	120	143	183	229	105	1,83 1,80 1,65
		NTU 150 MT	233-00 233-16 233-05	Cu/Cu Al/Al Al/Al	10,40	9,4 8,3 8,0	175	1	1	83	109	140	150	178	227	284	131	1,84 1,78 1,65
		NTU 170 MT	234-00 234-16 234-05	Cu/Cu Al/Al Al/Al	11,55	10 8,5 8,5	175	1	1	92	122	159	170	206	262	327	149	1,83 1,78 1,65
		NTU 185 MT	235-05	Al/Al	12,46	8,6	175	1	1	99	132	173	185	226	288	359	161	1,65

*All models are certified by VDE or TUV and TSE.

VNTZ MODELS

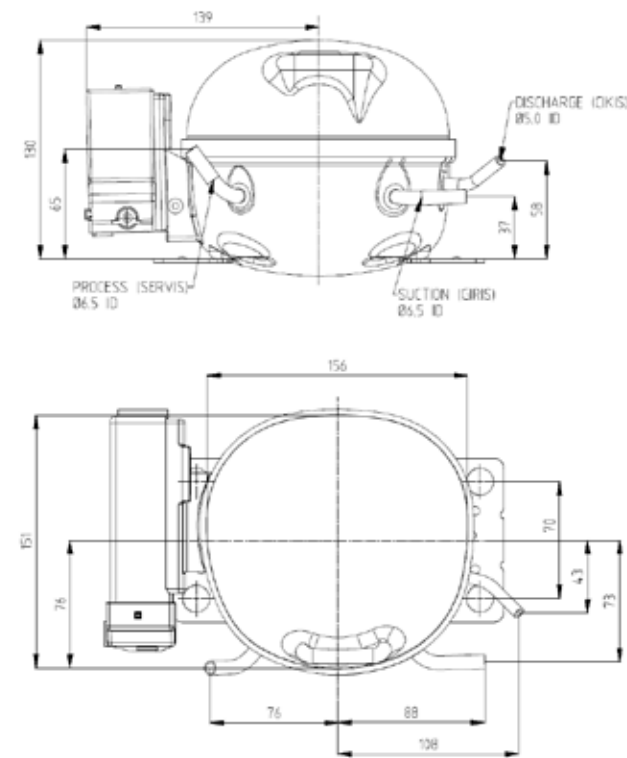

Refrigerant	Application	Model	B/M No	Displacement		Net Wt.	Oil Charge	Motor Type	Voltage and Frequency	Refrigerating Capacity		COP	Speed	Control Method	Standard Approval		
				cc	kg					Ashrae						W/W	rpm
										Kcal/h	W/W						
R600a	LBP	VNTZ 105 M	258-05	7,53	6,0	210	2	2	45	1,57	1300						
									76	1,75							
		VNTZ 105 M	258-00	7,53	6,0	210	2	2	45	1,80	1300						
									76	1,88							
		VNTZ 145 M	255-05	9,85	6,5	210	2	2	63	1,71	1300						
									105	1,75							
VNTZ 145 M	255-00	9,85	6,5	210	2	2	63	1,80	1300								
							105	1,86									
VNTZ 165 M	256-05	11,28	6,5	210	2	2	75	1,69	1300								
							124	1,75									
VNTZ 165 M	256-00	11,28	6,5	210	2	2	75	1,79	1300								
							124	1,87									

* VDE Certificate is ready for VNTZ165 / 256-05 model, for the other models; the certificate will be ready in 4th quarter of 2016

OTHERS DETAILS

Compressor Mounting Shapes

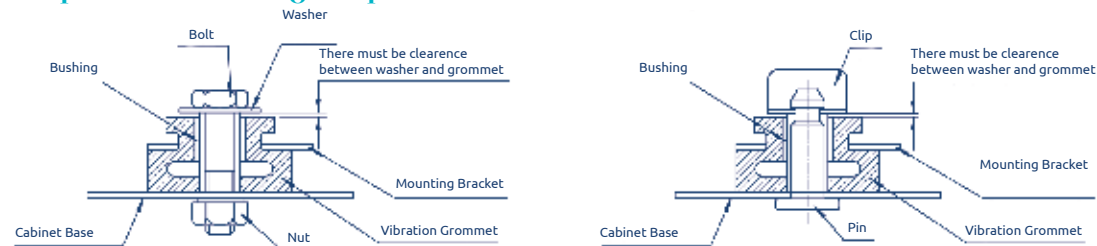

Dimensions

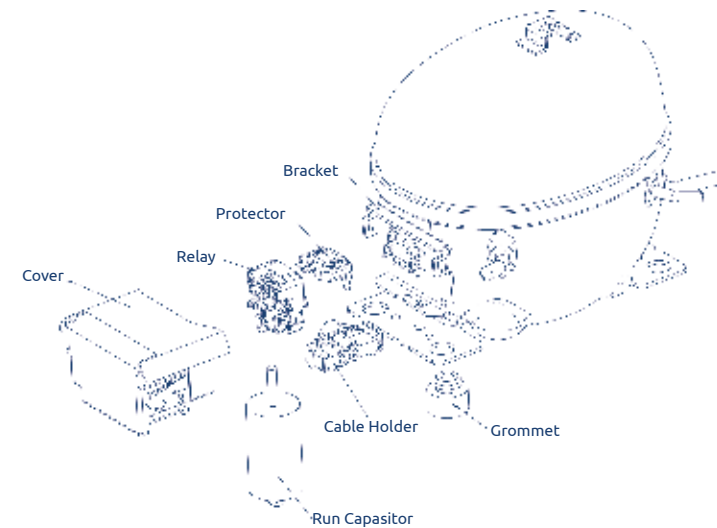

Compressor Identification

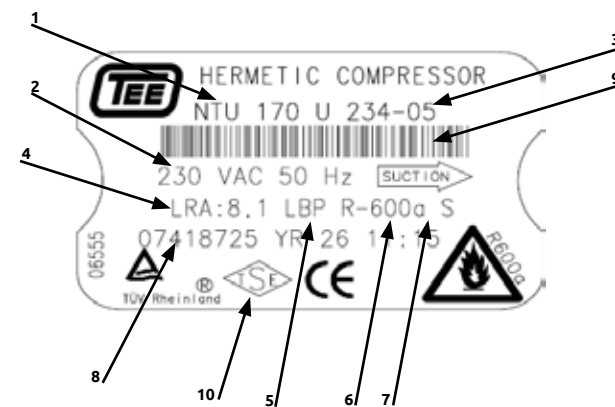

- | | |
|--|---|
| <ol style="list-style-type: none"> 1. COMPRESSOR MODEL NO $\frac{NTU}{a} \frac{170}{b} \frac{M}{c}$
DEFINITION
a. Compressor Design: NTU
b. Capacity: Compressor cooling capacity (Kcal/hr at 50 Hz) at standart ASHRAE-T conditions
c. Refrigerant R600a 2. RATED VOLTAGE AND FREQUENCY 3. COMPRESSOR B/M (Bill of Material) NO 4. LOCKED ROTOR CURRENT 5. APPLICATION
LBP: Low Back Pressure | <ol style="list-style-type: none"> 6. REFRIGERANT R600a 7. COOLING TYPE
S: Static
O: Oil
F: Fan 8. SERIAL NUMBER AND DATE MANUFACTURE 9. B/M NUMBER, SERIAL NUMBER, DATE OF MANUFACTURE BARCODE 10. APPROVAL |
|--|---|

WIRING DIAGRAMS

PTCSIR

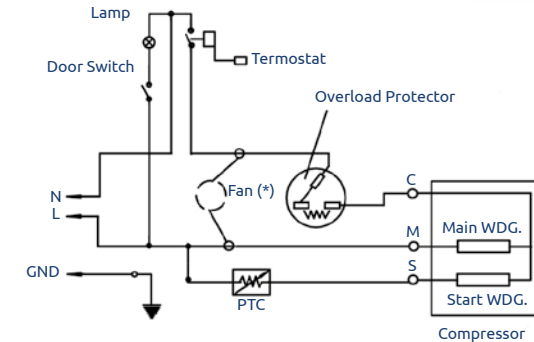

(*) Fan connection only on the models specified as fan cooled

PTCSCR

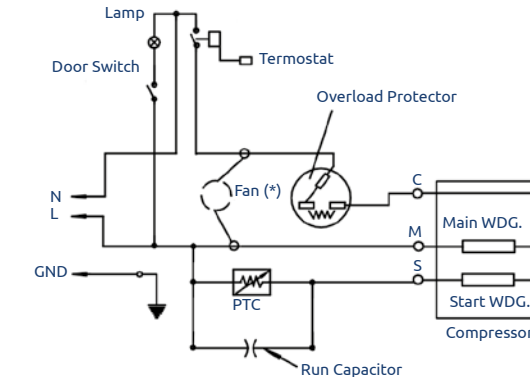

(*) Fan connection only on the models specified as fan cooled

E-PTCSCR

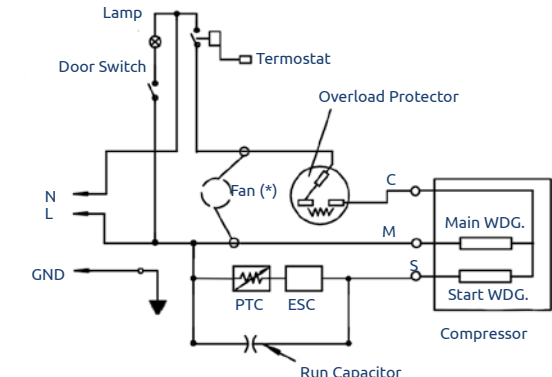

(*) Fan connection only on the models specified as fan cooled

OTHER DETAILS

Inverter

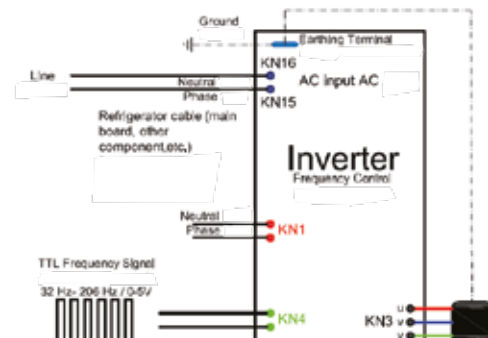
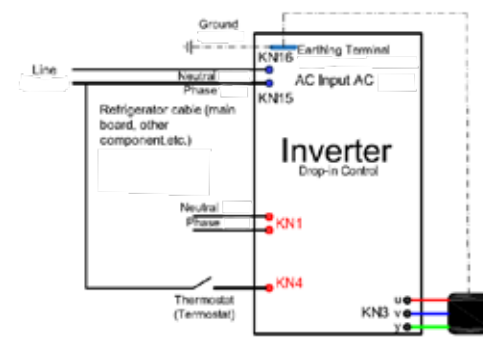

Compressor Identification

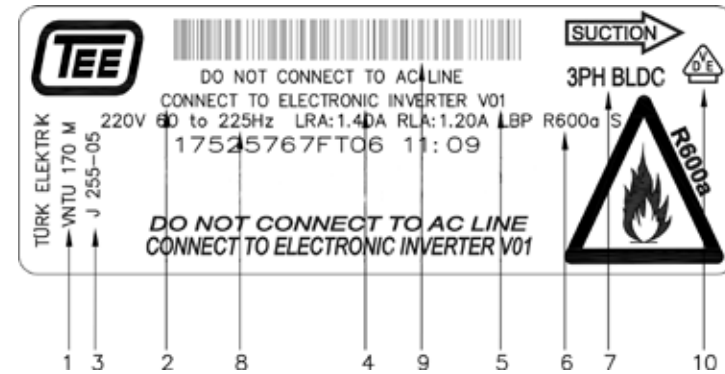

- | | |
|--|--|
| <p>1. COMPRESSOR MODEL NO $\frac{VNTU}{a} \frac{170}{b} \frac{MT}{c}$
DEFINITION
a. Compressor Design: VNTU
b. Capacity: Compressor cooling capacity (Kcal/hr at 50 Hz) at standard ASHRAE-T conditions
c. Refrigerant R600a</p> <p>2. RATED VOLTAGE AND FREQUENCY</p> <p>3. COMPRESSOR B/M (Bill of Material) NO</p> <p>4. LOCKED ROTOR CURRENT</p> <p>5. APPLICATION
LBP: Low Back Pressure</p> | <p>6. REFRIGERANT R600a</p> <p>7. COOLING TYPE
S: Static
O: Oil
F: Fan</p> <p>8. SERIAL NUMBER AND DATE MANUFACTURE</p> <p>9. B/M NUMBER, SERIAL NUMBER, DATE OF MANUFACTURE BARCODE</p> <p>10. APPROVAL</p> |
|--|--|

APPLICATION SPECIFICATIONS – NOTIFICATIONS

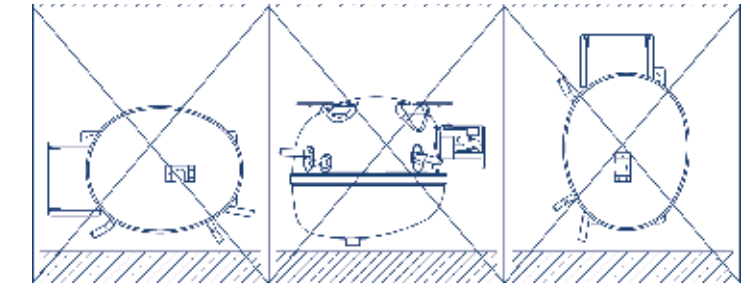
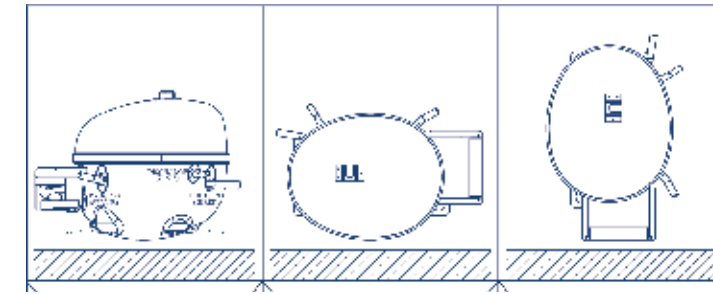

- Do not leave compressors without their plugs more than 10 minutes. Compressors with rubber cap removed; must be attached to the system as soon as possible.
- Don't incline the compressors more than 5° during storage, transportation or installation and transportation must be made considering attached drawings. In addition to this avoid compressors from vibration and impact shock during transportation.
- A dropped or highly impacted compressor must not be used.
- Due to the reason that R600a is highly flammable, all components; especially including leakage test equipment must be exclusively designed for R600a and the system must be welded securely.
- Excessive liquid back in refrigeration system must be avoided to prevent wear on bearings. Furthermore; liquid back can result in cause breakage on the crankshaft, rupture on the gasket and damage to the suction valve of the compressor.
- Do not apply direct AC power on terminals of the compressor.
- The design of refrigeration system must be suitable to ensure that the oil inside the compressors could flow back to compressor after completing the refrigeration cycle.
- Compressors should be stored in a dry, non-humid place.
- The stocking period must be less than 12 months after the

- production date. If longer, vacuum levels of the compressors should be checked before usage.
- Use a filter dryer suitable for R600a refrigerant.
- Do not operate or supply electrical power unless compressor is connected to ground, electric shock may occur.
- The compressor must not be subjected to high voltage tests under vacuum conditions. All TEE compressors have already been submitted to 1.860 V for one second for electrical safety standards.
- Electrical power must be disconnected when terminal protective cover is not in place to avoid electric shock.
- The TEE Electronic Inverter is made for use only with the TEE VNTU Compressors.
- Inverter Compressors should be driven by suitable inverter; otherwise compressor in order to reach best performance.
- Do not connect the inverter compressors directly to the AC supply line, otherwise permanent damage may occur.

HEAVY DUTY CARTON BOX



STACKING: MAXIMUM 3 PALLETS

MODELS / MODELLER	COMPRESSOR / PALLET
COMPACT INVERTER	123
MINI-L	100
MIDI	80

All dimensions are in mm.

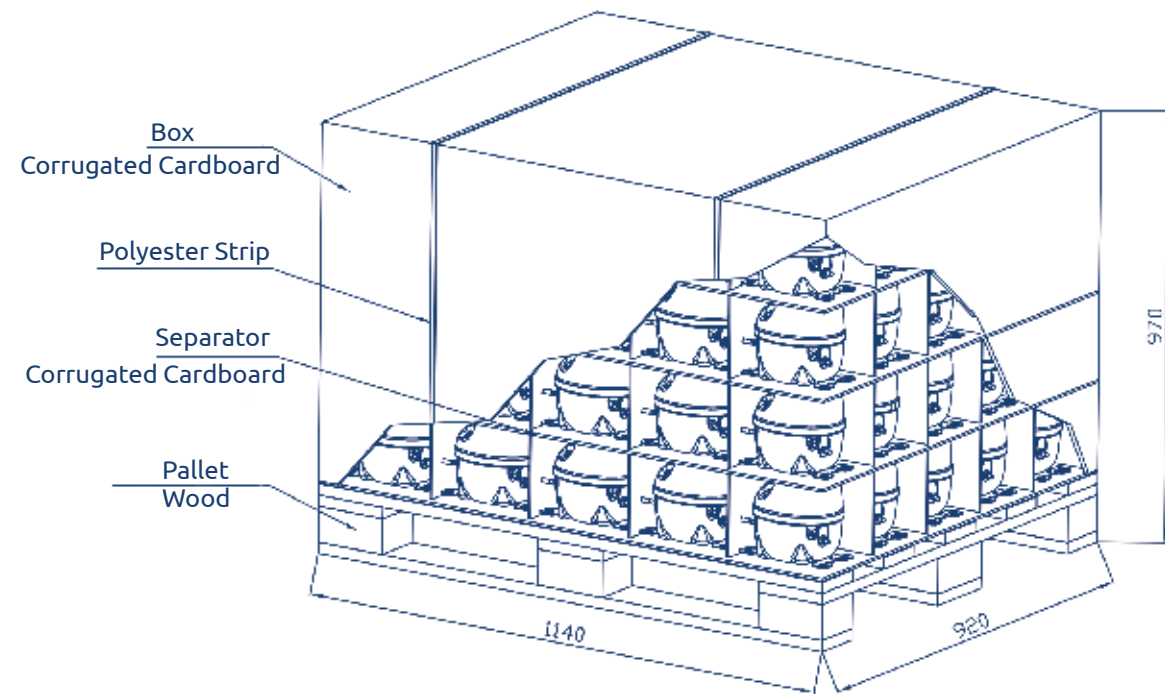

WOODEN PALLET TYPE



STACKING: MAXIMUM 2 PALLETS

MODELS / MODELLER	COMPRESSOR / PALLET
ALL	80

All dimensions are in mm.

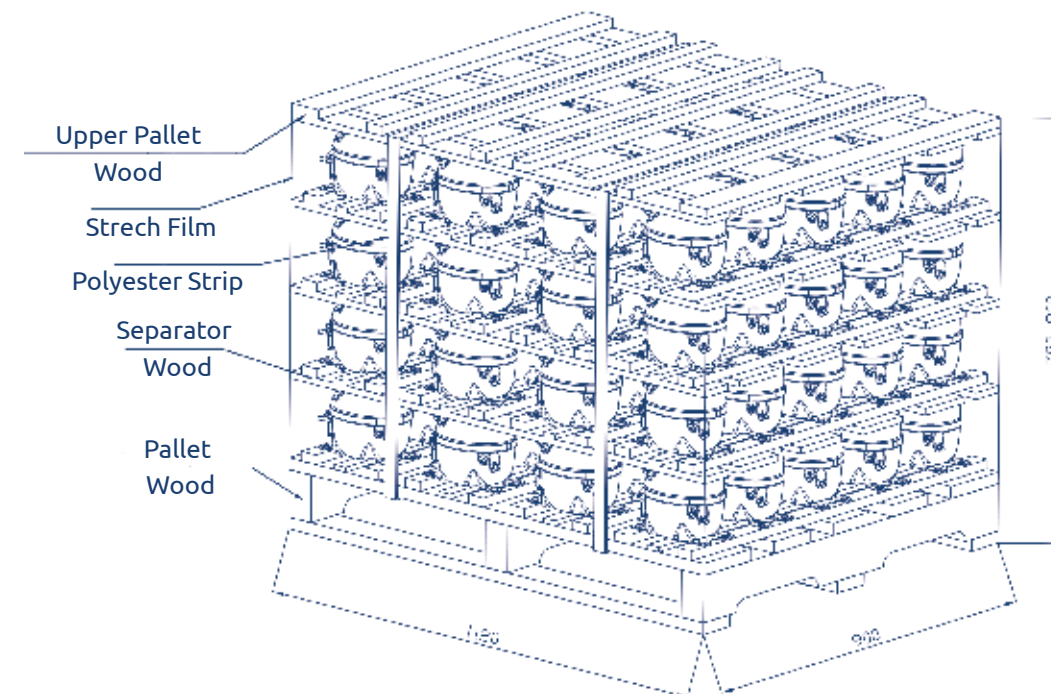

TEST CONDITIONS

MOTOR TYPES

1 PTCSCR
2 BLDC

VOLTAGE AND FREQUENCY

1 220-240V / 50 Hz --- 230V / 50 Hz
2 220-240V / 50 Hz -- 60 Hz

CONVERSION FACTORS

Kcal/h x 1,163 = W
Kcal/h x 3,968 = Btu/h
W x 3,412 = Btu/h
W x 0,864 = Kcal/h
Capacity(at 50Hz) x 1,16 = Capacity (at 60Hz)
cc x 0,061 = Cu. in.

TOLERANCES

Refrigerating Capacity = $\pm 7\%$

Efficiency = $\pm 7\%$

All data based on 220V - 50Hz.

	ASHRAE		CECOMAF	
	LBP	HBP	LBP	HBP
Evaporating Temperature °C	-23,3	7,2	-25,0	5,0
Condensing Temperature °C	54,4	54,4	55,0	55,0
Liquid Temperature °C	32,2	46,1	55,0	55,0
Ambient Temperature °C	32,2	35,0	32,0	32,0
Gas Suction Temperature °C	32,2	35,0	32,0	32,0

SALES OFFICE

Karaağaç Cad. No: 2-6
Sütlüce 34445 Istanbul,
Turkey

PHONE

+90 212 314 34 34

FAX

+90 212 314 34 86

E-MAIL

feedback-tee@arcelik.com

WEB

www.tee.com.tr

