

Model

Designation	SC15MFX	220-240V/50Hz 1~	Sales code:	104G8501
-------------	----------------	-------------------------	-------------	-----------------

Compressor design

Oil type	Polyolester	Refrigerant(s)	R134a, R513A
Oil viscosity	22cST	Displacement	15,28cm ³ / 0,93cu.in
Oil quantity	449cm ³ / 15,2fl.oz	Compressors on pallet	80
Refr. charge - tech. limit	1300g / 45,9oz		
Free gas volume comp.	1410cm ³ / 47,7fl.oz		
Weight	13,2kg / 29,1lbs		
Motor protection	1# internal		
Winding resistance main	5,13Ω (at 25°C)		
Winding resistance aux	13,51Ω (at 25°C)		
Max. winding temp.	125°C / 257°F		
Max. discharge temp.	130°C / 266°F		



General - Configurations with SC15MFX

	Conf. 1	Conf. 2
Motorconfiguration	CSIR	CSIR
Power supply (nominal)	220-240V/50Hz	220-240V/50Hz
Number of phases	1	1
Voltage range	198-254V	198-254V
Approvals	VDE, CCC, EAC	VDE, CCC, EAC
Starting torque	HST	HST
Note	- / -	

Applications with SC15MFX

	Conf. 1	Conf. 2
Refrigerant	R134a	R513A
Application	MBP	MBP
System cooling	fan 3m/s	fan 3m/s
Hot gas defrost	OK	OK
Long interval pull down	OK	OK

Electrical data - Configurations with SC15MFX

	Conf. 1	Conf. 2
Starting device type	relay	relay
Run capacitor	-/-	-/-
Start capacitor	80μF	80μF
LRA (locked rotor amps / 4s)	16,2A	16,2A
RLA (rated load amps / 1s)	3,1A	3,1A
Cut in current	16,2A	16,2A

Model

Designation	SC15MFX	220-240V/50Hz 1~	Sales code:	104G8501
-------------	----------------	------------------	-------------	-----------------

Compressor dimensions

Housing	A Height	209mm / 8,23in
	B Height	203mm / 7,99in
	C Length shell	218mm / 8,58in
	D Length w. cover	255mm / 10,04in
	E Width	151mm / 5,94in

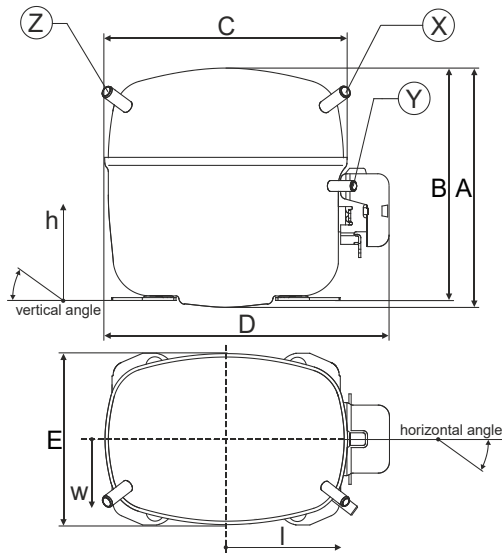

Connectors	Suction		Discharge		Process	
	X		Y		Z	
Diameter [mm]	øi 10,11-10,29		øi 6,11-6,29		øi 6,11-6,29	
(i:inside, o:outside) [in]	øi 0,4-0,41		øi 0,24-0,25		øi 0,24-0,25	
Material	copper		copper		copper	
Horizontal angle ±2°	37°		37°		143°	
Vertical angle ±2°	30°		0°		150°	
Position l/h/w [mm]	107/183/55		115/100/63		-107/183/55	
[in]	4,2/7,2/2,2		4,5/3,9/2,5		-4,2/7,2/2,2	
Straight tube l. [mm]	12		12		12	
[in]	0,5		0,5		0,5	

Compressor fixation

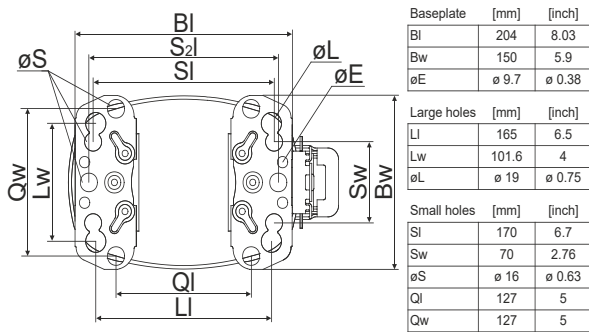

Bolt joint

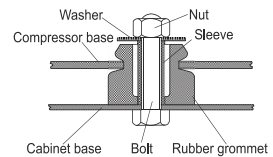

Snap-on

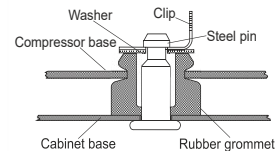

Mounting accessories	one comp.	multi pack
Bolt joint M6 ø16mm	118-1917	118-1918
Bolt joint ø1/4" ø16mm	118-1946	
Bolt joint ø1/4" ø19mm	118-1949	
Snap-on ø7,3 ø16mm	118-1947	118-1919

Application notes

Provision for PE Grounding is located at the PE Stamp on the compressor

Model

Designation	SC15MFX	220-240V/50Hz	Conf. 1	Sales code:	104G8501
-------------	----------------	----------------------	---------	-------------	-----------------

Configuration

Motorconfiguration	CSIR
Power supply (nominal)	220-240V/50Hz 1~
Refrigerant	R134a
Application	MBP
Voltage range	198-254V
Starting torque	HST
Approvals	VDE
	CCC
	EAC

Electrical accessories / wiring diagram

CSIR

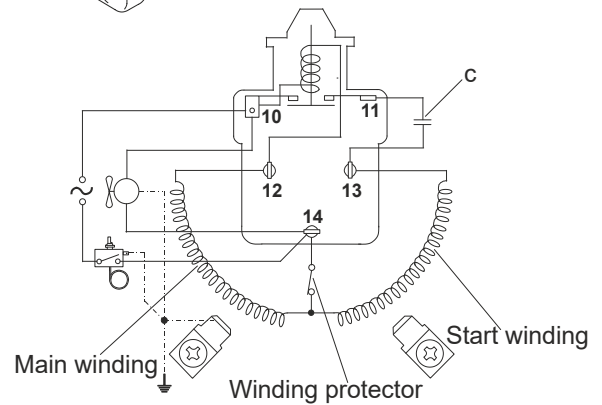
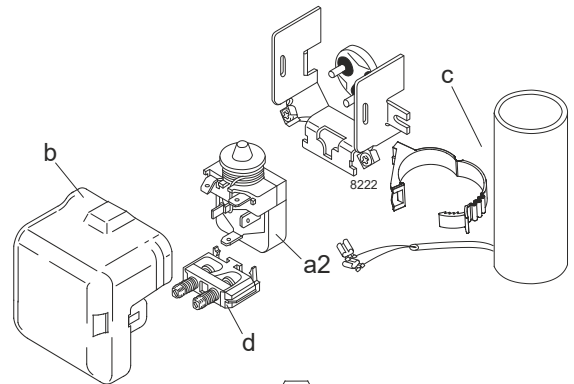

Ambient/ machine room temperatures minimum /maximum

Ambient temperature range: 10 - 43°C / 50 - 110°F

Machine room temperature range: 10 - 48°C / 50 - 119°F

Compressor cooling: fan 3m/s

Operation Limits

Operation pressure range

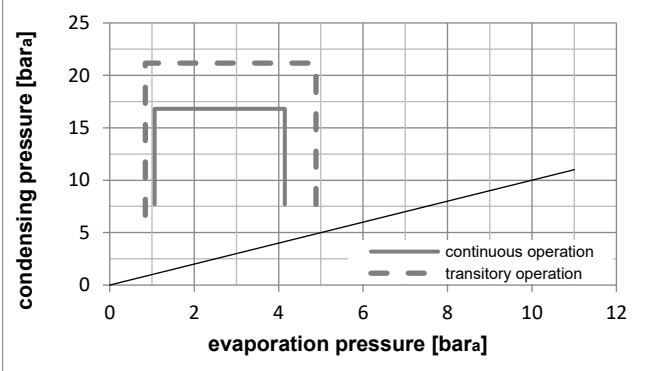
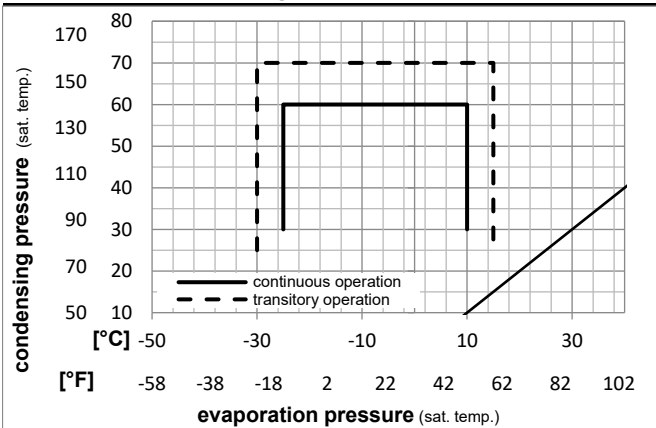

Components

a2	relay	117U6005
c	start capacitor (80µF)	117U5017
d	cord relief	103N1004
b	plastic cover	103N2008

Model

Designation	SC15MFX	220-240V/50Hz	Conf. 1	Sales code:	104G8501
-------------	----------------	----------------------	---------	-------------	-----------------

Optimization + standard conditions

R134a, 220V/50Hz, CSIR, fan 3m/s, VDE, CCC, EAC

Evaporating pressure (saturation temperature)				Condensing pressure (saturation temperature)			Return gas temp.			Liquid temp.			Cooling capacity			COP	EER	Power consumption			Ref. mass flow m	ASHRAE MBP
pe	pc	RGT	Tliq	[W]	[Btu/h]	[kcal/h]	[W/W]	[Btu/Wh]	[kcal/Wh]	P1	I	[kg/h]										
[°C]	[°F]	[°C]	[°F]	[W]	[Btu/h]	[kcal/h]	[W/W]	[Btu/Wh]	[kcal/Wh]	[W]	[A]	[kg/h]										
-7	54	35	46	786,3	2685	676,7	1,66	5,68	1,43	472,7	2,90	17,16	ASHRAE MBP									
[°F]	20	130	95																			
-10	55	32	55	601,6	2054	517,7	1,38	4,70	1,18	437,4	2,78	14,55	cecomaf MBP									
[°F]	14	131	90																			
-10	45	20	45	676,2	2309	582,0	1,63	5,57	1,40	414,4	2,70	15,83	EN12900 MBP									
[°F]	14	113	68																			
-7	49	18	49	746,6	2550	642,6	1,63	5,57	1,40	458,1	2,85	18,44	ARI540 MBP									
[°F]	20	120	65																			
-10	45	32	45	701,6	2396	603,8	1,69	5,78	1,46	414,4	2,70	15,35	opt									
[°F]	14	113	90																			
-25	45	32	45	290,0	990	249,6	1,07	3,66	0,92	270,3	2,25	6,28	opt									
[°F]	-13	113	90																			

Performance tables

R134a, 220V/50Hz, CSIR, fan 3m/s, VDE, CCC, EAC

	pe		Cooling capacity			COP	EER		P1	I	m
	[°C]	[°F]	[W]	[Btu/h]	[kcal/h]	[W/W]	[Btu/Wh]	[kcal/Wh]	[W]	[A]	[kg/h]
[°C / °F]	-25	-13	290,0	990	249,6	1,07	3,66	0,92	270,3	2,25	6,28
cond. pressure	-20	-4	404,0	1380	347,7	1,27	4,33	1,09	318,8	2,40	8,78
pc= 45/113	-15	5	540,6	1846	465,2	1,47	5,03	1,27	367,3	2,55	11,78
return gas temp.	-10	14	701,6	2396	603,8	1,69	5,78	1,46	414,4	2,70	15,35
RGT= 32/90	0	32	1103,7	3769	949,9	2,21	7,55	1,90	499,5	2,99	24,41
liquid temp	5	41	1348,3	4605	1160,4	2,52	8,61	2,17	534,8	3,13	30,02
Tliq= 45/113	10	50	1624,3	5547	1397,9	2,88	9,84	2,48	563,6	3,25	36,45
[°C / °F]	-25	-13	225,8	771	194,3	0,81	2,77	0,70	278,2	2,30	5,40
cond. pressure	-20	-4	332,9	1137	286,5	1,01	3,45	0,87	329,5	2,44	7,99
pc= 55/131	-15	5	457,6	1563	393,8	1,19	4,08	1,03	383,0	2,61	11,02
return gas temp	-10	14	601,6	2054	517,7	1,38	4,70	1,18	437,4	2,78	14,55
RGT= 32/90	0	32	954,2	3259	821,2	1,75	5,99	1,51	543,7	3,16	23,34
liquid temp	5	41	1166,3	3983	1003,8	1,97	6,72	1,69	592,9	3,35	28,74
Tliq= 55/131	10	50	1404,7	4797	1208,9	2,20	7,52	1,90	637,8	3,55	34,92

Model

Designation	SC15MFX	220-240V/50Hz	Conf. 2	Sales code:	104G8501
-------------	----------------	----------------------	---------	-------------	-----------------

Configuration

Motorconfiguration	CSIR
Power supply (nominal)	220-240V/50Hz 1~
Refrigerant	R513A
Application	MBP
Voltage range	198-254V
Starting torque	HST
Approvals	VDE
	CCC
	EAC

Electrical accessories / wiring diagram

CSIR

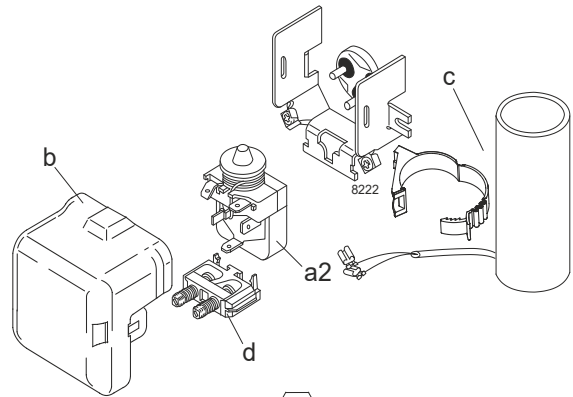

Ambient/ machine room temperatures minimum /maximum

Ambient temperature range:	10 - 43°C / 50 - 110°F
Machine room temperature range:	10 - 48°C / 50 - 119°F
Compressor cooling:	fan 3m/s

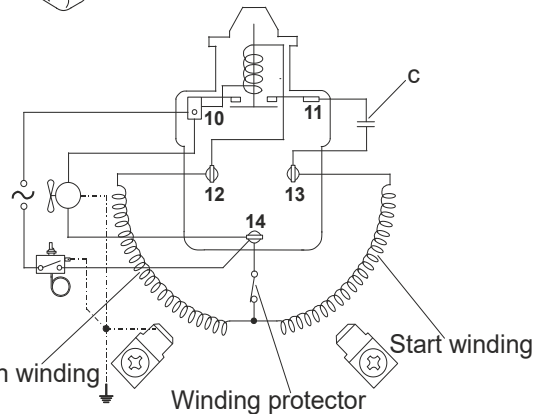

Operation Limits

Operation pressure range

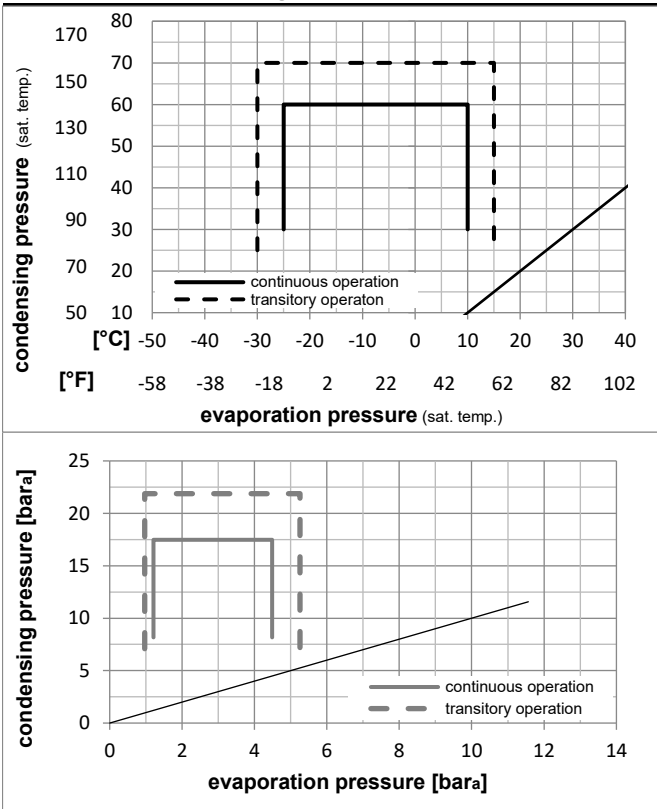

Components

a2	relay	117U6005
c	start capacitor (80µF)	117U5017
d	cord relief	103N1004
b	plastic cover	103N2008

Model

Designation	SC15MFX	220-240V/50Hz	Conf. 2	Sales code:	104G8501
-------------	----------------	----------------------	----------------	-------------	-----------------

Optimization + standard conditions

R513A, 220V/50Hz, CSIR, fan 3m/s, VDE, CCC, EAC

		Evaporating pressure (saturation temperature)				Condensing pressure (saturation temperature)						Power consumption					
		Return gas temp.				Liquid temp.						Current consumption			Ref. mass flow		
		Cooling capacity				COP		EER		P1	I	m					
		pe	pc	RGT	Tliq	[W]	[Btu/h]	[kcal/h]	[W/W]	[Btu/Wh]	[kcal/Wh]	[W]	[A]	[kg/h]			
[°C]	[°F]																
-7	20	54	130	35	95	46	115	826,7	2823	711,5	1,65	5,63	1,42	501,1	3,01	20,25	ASHRAE MBP
-10	14	55	131	32	90	55	131	625,3	2136	538,2	1,34	4,59	1,16	465,2	2,89	17,29	cecomaf MBP
-10	14	45	113	20	68	45	113	708,0	2418	609,3	1,61	5,51	1,39	438,7	2,80	18,76	EN12900 MBP
-7	20	49	120	18	65	49	120	771,4	2634	663,9	1,59	5,43	1,37	484,8	2,96	21,74	ARI540 MBP
-10	14	45	113	32	90	45	113	740,3	2528	637,1	1,69	5,76	1,45	438,7	2,80	18,20	opt
-25	-13	45	113	32	90	45	113	317,5	1084	273,2	1,11	3,79	0,95	286,1	2,30	7,74	opt

Performance tables

R513A, 220V/50Hz, CSIR, fan 3m/s, VDE, CCC, EAC

	pe		Cooling capacity			COP		EER		P1	I	m
	[°C]	[°F]	[W]	[Btu/h]	[kcal/h]	[W/W]	[Btu/Wh]	[kcal/Wh]	[W]	[A]	[kg/h]	
[°C / °F]	-25	-13	317,5	1084	273,2	1,11	3,79	0,95	286,1	2,30	7,74	
cond. pressure	-20	-4	435,9	1489	375,2	1,29	4,40	1,11	338,3	2,47	10,65	
pc= 45/113	-15	5	576,3	1968	496,0	1,48	5,05	1,27	389,6	2,64	14,12	
return gas temp.	-10	14	740,3	2528	637,1	1,69	5,76	1,45	438,7	2,80	18,20	
RGT= 32/90	0	32	1145,4	3912	985,8	2,18	7,45	1,88	525,0	3,09	28,41	
liquid temp	5	41	1389,8	4746	1196,0	2,48	8,48	2,14	559,5	3,20	34,66	
Tliq= 45/113	10	50	1664,1	5683	1432,1	2,84	9,69	2,44	586,6	3,29	41,78	
[°C / °F]	-25	-13	245,0	837	210,9	0,82	2,81	0,71	297,3	2,34	6,71	
cond. pressure	-20	-4	354,8	1212	305,4	1,01	3,44	0,87	352,5	2,52	9,74	
pc= 55/131	-15	5	481,1	1643	414,0	1,18	4,02	1,01	408,9	2,71	13,25	
return gas temp	-10	14	625,3	2136	538,2	1,34	4,59	1,16	465,2	2,89	17,29	
RGT= 32/90	0	32	974,5	3328	838,7	1,70	5,81	1,47	572,3	3,24	27,21	
liquid temp	5	41	1182,6	4039	1017,7	1,91	6,51	1,64	620,5	3,40	33,23	
Tliq= 55/131	10	50	1415,1	4833	1217,9	2,13	7,29	1,84	663,2	3,54	40,06	