

OPERATION:

Application:	L.B.P.	Max. Ambient Temp:	43°C
Refrigerant:	R600a	(1) Max. Steady Discharge Temp:	120°C
Operation:	Capillary	(1,2) Max. Peak Discharge Temp:	135°C
Cooling:	Static	Max. Steady Condensing Temp:	60°C
		(2) Max. Peak Condensing Temp:	70°C
		Max. Winding Temp:	130°C
		Max. Impurities:	30 mg
		Max.Total Compressor Water Content:	100 mg

COMPRESSOR:

Displacement:	6.64 cc	Oil Type:	Mineral
Bore:	21.10 mm	(4) Viscosity:	7 cSt
Stroke:	19.00 mm	Suction Muffler:	Semi-direct
(3) Net Wt:	8.6 kg		
Case Size:	1 (h = 157.5 mm)		
Oil Charge:	165 cc		

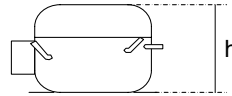

ELECTRICAL:

Power Supply:	220 - 240V	Motor Type:	RSCR
Voltage Limits:	187 - 264V	Locked Rotor Current:	7.2 / 2.7 A**
Frequency:	50 Hz		
Phase:	1 ph		
		Main Winding Resistance at 25°C:	28.1 Ω
		Start Winding Resistance at 25°C:	24.6 Ω

** Maximum current / Measured after 4 seconds

- (1) Measured 5cm. from the shell with insulated thermocouples
- (2) For transient conditions during 'Pull Down'
- (3) Net weight is with oil but without electrics
- (4) Measured at 40°C

For rated performance,

the suction line must be connected to the stub marked 'AS' on the attached drawing.

A run capacitor must be used with RSCR and CSR compressors.



HTK70AA

PRODUCT SPECIFICATION

ELECTRICAL COMPONENTS:

ECC Starting Device: K 100-xx
(1) ZEM Starting Device: PTC- 7100D3 / 8100
ZEM PTC Resistance: 14 Ω
'Combo' PTC Resistance: 14 Ω
Run Capacitor: 2.5 μF

-xx Protector short code

PROTECTORS:

PROTECTORS	BDG ¾	Combo	Electrica ¾	Texas ¾	Texas 4TM
Type	AE 25 FU x	C2-174 NFBYY xx	T 0602 / kk	MSP 334HZ xxxx	4TM 174 NFBYY xx
Open °C	115 - 125 °C	115 - 125 °C	115 - 125 °C	115 - 125 °C	115 - 125 °C
Close °C	71 - 53 °C	70 - 52 °C	70 - 55 °C	70 - 52 °C	70 - 52 °C
U.T.C	1.15 A 70 °C	1.23 A 70 °C	1.32 A 70 °C	1.35 A 70 °C	1.23 A 70 °C
Time Check Current	4.30 A	4.8 A (5-15s)	4.50 A	4.40 A	4.8 A (5-15s)
Max. Current	10.0 A	10.4 A (2s max.)	10.0 A	12.0 A	10.4 A (2s max.)
Code (if any)	F2	24	C6	V5	

Alt. protectors: AF 25 FU x
D3

PTC-71.. / 81.. and Combo are for Terminal Cover version only.

(1) BDG protector AF type is for use with PTC-71.. only, and PTC-71.. is only fitted with BDG protector.

PERFORMANCE: (Graphs are at ASHRAE conditions)

220V 50Hz

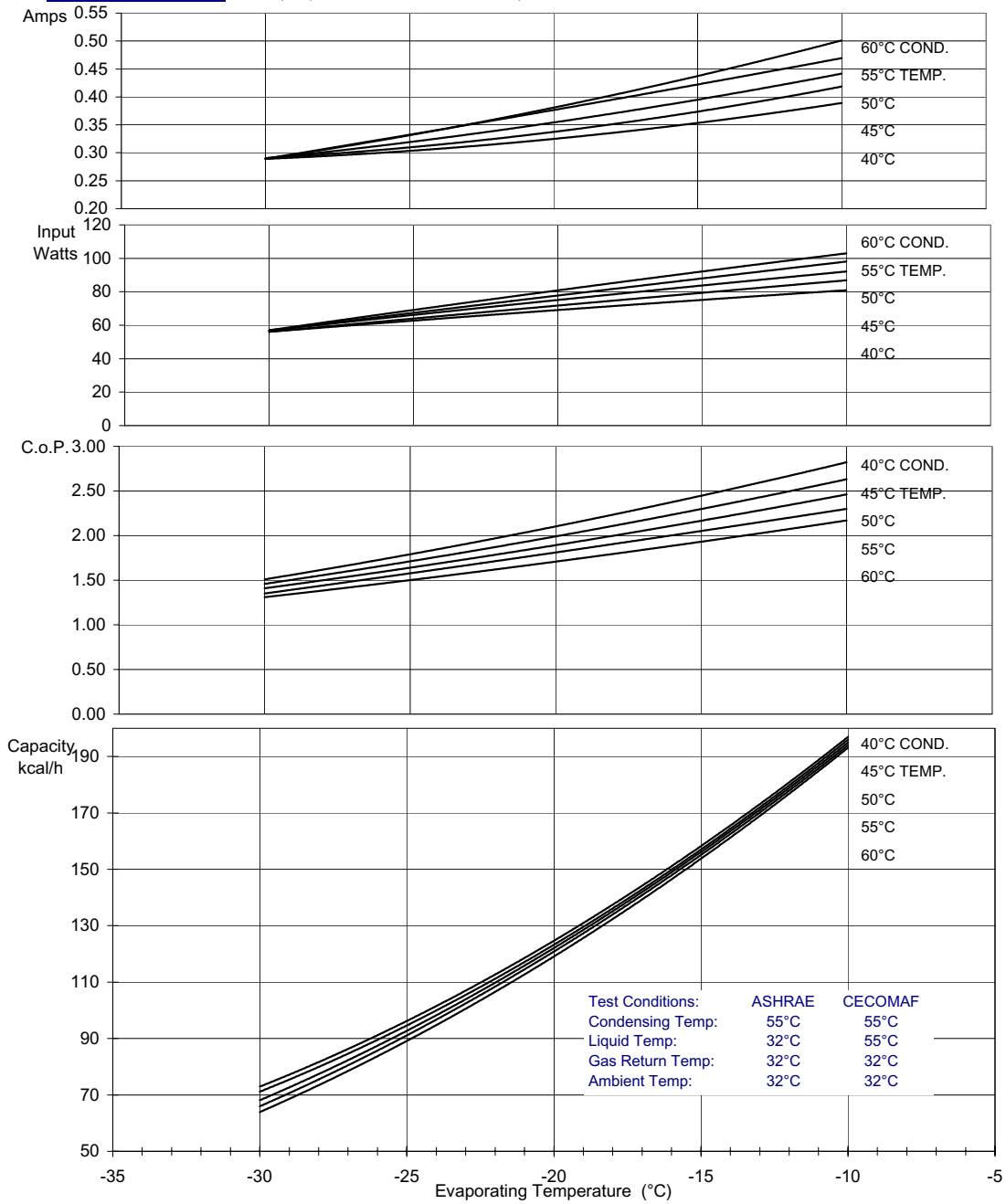

Test Conditions:	ASHRAE	CECOMAF
Condensing Temp:	55°C	55°C
Liquid Temp:	32°C	55°C
Gas Return Temp:	32°C	32°C
Ambient Temp:	32°C	32°C

	Evaporating Temperature °C	-30	-25	-23.3	-20	-15	-10	
ASHRAE:	Capacity	Kcal/h	66	91	101	121	155	194
	C.o.P.	W / W	1.35	1.58	1.66	1.81	2.05	2.30
CECOMAF:	Capacity	W	63	87		116	148	185
	C.o.P.	W / W	1.11	1.30		1.49	1.68	1.89
	Input Power	W	57	67	71	78	88	98
	Current	A	0.29	0.33	0.34	0.38	0.42	0.47

Circuit Diagram for ECC Terminal Board Standard Version

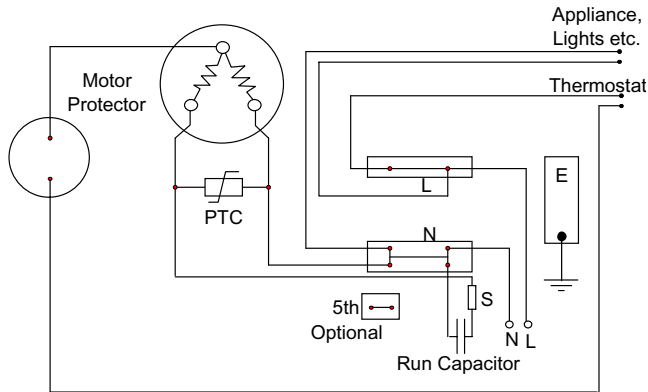

Circuit Diagram for ECC Terminal Board Frontal Version

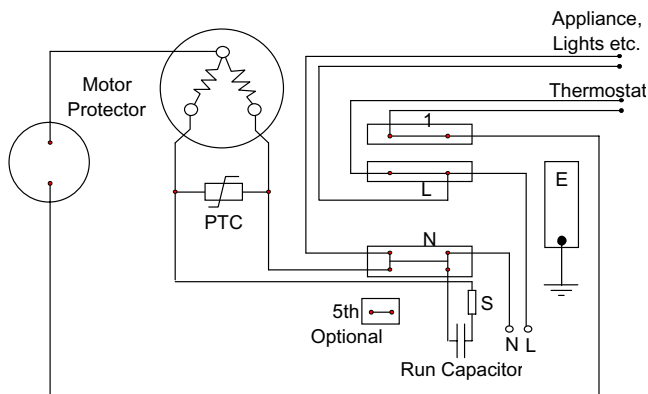

Circuit Diagram for ECC Terminal Board Rast 5 Version

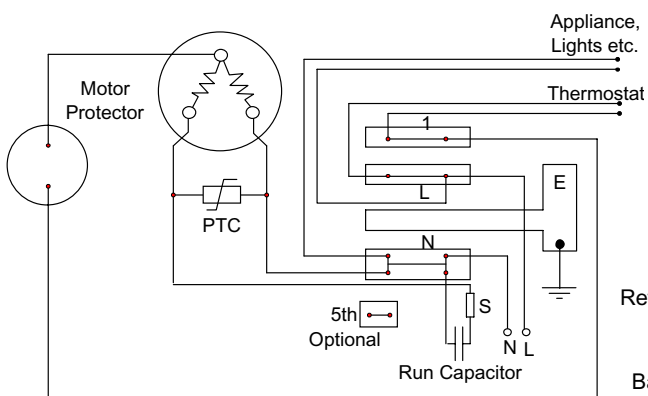

Mounting Accessories

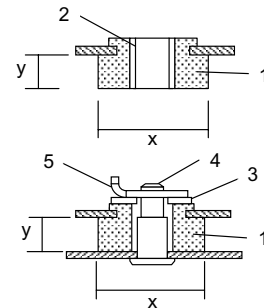

x = 26mm or 28.5mm
y = 9mm or 10.3mm
Other sizes available

1. Rubber grommet
2. Sleeve
3. Washer
4. Steel pin
5. Clip

Recommended Transport Positions when fitted into appliances

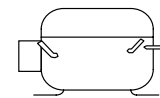

Upright

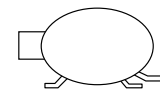

Tubes Down

Compressor Label

