

LG Refrigeration Compressor

TS/NS

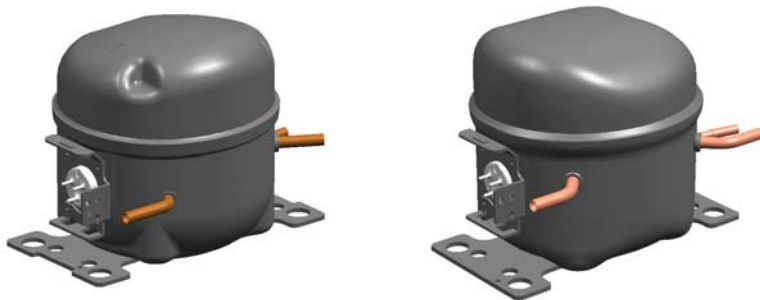

Compressor & Motor Division



LG Electronics / Home Appliance Company

※ The numerical values shown in this material have been obtained based on current model.
They might be changed or modified by mutual agreement with customer in the future



TS series & NS series

Application

Small size refrigerator, freezer & water dispenser

Specifications

LBP

60Hz

Voltage/ Frequency	Model	Disp. (cc/rev)	ASHRAE					Motor Type	ELECTRICAL PARTS				Oil Charge (cc)	Net Weight (kg)	Development
			Capacity (-23.3 °C)			Consumption Power (w)	EER (Btu/wh)		Starting Device	Motor Protector	Capacitor				
			kcal/h	w	Btu/h						Starting (MFD/VAC)	Running (MFD/VAC)			
110-115/60	NS24LBQG	2.42	43	50	171	70	2.44	RSIR	P6R8MC	4TM232NFB			180	6.4	
	NS30LAQG	3.05	61	71	242	85	2.85	RSIR	P6R8MC	4TM265RFB			180	6.4	
	NS36LAQG	3.58	77	90	306	100	3.05	RSIR	P3R9MC	4TM314TFB			180	6.4	
	NSB30LAQG	3.05	76	88	302	97	3.00	RSIR	P3R9MC	4TM314TFB			180	6.4	
115/60	TS24LACG	2.44	48	56	191	78	2.44	RSIR	P6R8MC	4TM265MFB			160	5.3	
	NS24LACG	2.42	45	52	179	77	2.32	RSIR	P6R8MC	4TM265MFB			180	5.8	
	NS24LBCG	2.42	43	50	171	70	2.44	RSIR	P6R8MC	4TM232NFB			180	6.4	
	NS24LBCM	2.42	43	50	171	67	2.55	RSCR	P6R8MD	4TM232NFB		10/250	180	6.4	
	NS30LACG	3.05	64	74	254	89	2.85	RSIR	P6R8MC	4TM265RFB			180	6.4	
	NS30LACM	3.05	64	74	254	85	2.99	RSCR	P6R8MD	4TM265RFB		10/250	180	6.4	
	NS30LHCG	3.05	66	57	262	92	2.85	RSIR	QP2-6R8MC	4TM265RFB			180	7.3	©
	NS36LACG	3.58	79	92	314	102	3.07	RSIR	P6R8MC	4TM276TFB			180	6.4	
	NSA24LACG	2.42	50	58	199	80	2.48	RSIR	P6R8MC	4TM265MFB			180	5.8	
	NSA30LACG	3.05	70	81	278	92	3.02	RSIR	P6R8MC	4TM265RFB			180	6.4	
	NSA30LACM	3.05	70	81	278	88	3.16	RSCR	P6R8MD	4TM265RFB		10/250	180	6.4	
	NSA36LACG	3.58	83	97	330	104	3.17	RSIR	P6R8MC	4TM276TFB			180	6.4	
	NSA43LACG	4.29	98	114	389	121	3.22	RSIR	P6R8MC	4TM314TFB			180	6.9	
	NSB24LACG	2.42	51	59	202	68	3.00	RSIR	P6R8MC	4TM265RFB			180	6.4	
	NSB30LACG	3.05	76	88	302	84	3.59	RSIR	P6R8MC	4TM265RFB			180	6.4	
NSB30LBCG	3.05	76	88	302	84	3.59	RSIR	P6R8MC	4TM265RFB			180	6.4		
NSB30LBCM	3.05	76	88	302	79	3.82	RSCR	P6R8MD	4TM265RFB		10/250	180	6.4		
NSB36LACG	3.58	90	105	357	102	3.50	RSIR	P6R8MC	4TM265RFB			180	6.4		
115-127/60	TS24LHUG	2.44	48	41	191	78	2.44	RSIR	P3R9MC	4TM213NFB			160	6.1	
127/60	TS24LAFG	2.44	48	56	191	80	2.38	RSIR	P6R8MC	4TM232TFB			160	5.3	
	NS24LAFG	2.42	43	50	171	80	2.13	RSIR	P6R8MC	4TM213SFB			180	5.8	
	NS24LAFM	2.42	43	50	171	79	2.16	RSCR	P6R8MD	4TM213SFB		8/250	180	5.8	
	NS30LAFG	3.05	61	71	242	87	2.78	RSIR	P6R8MC	4TM232VFB			180	6.4	
	NS30LAFM	3.05	61	71	242	84	2.88	RSCR	P6R8MD	4TM232VFB		8/250	180	6.4	
220/60	TS24LADG	2.44	46	53	183	73	2.50	RSIR	P330MC	4TM104RFB			160	5.3	
	TS24LBDM	2.44	48	56	191	78	2.45	RSCR	P220MD	4TM158RFB		3/400	160	5.3	
	TS24LHDG	2.44	50	58	197	74	2.65	RSIR	P330MC	4TM149NFB DRB16N61A1			160	6.1	
	TS24LJDG	2.44	50	58	197	78	2.53	RSIR	P220MC	4TM134VFB			160	6.1	©
	NS24LADG	2.42	43	50	171	76	2.25	RSIR	P220MC	4TM104RFB			180	5.8	
	NS24LADM	2.42	44	51	175	74	2.40	RSCR	P220MD	4TM232NFB		3/400	180	5.8	
	NS30LADG	3.05	64	74	254	90	2.82	RSIR	P220MC	4TM158RFB			180	6.4	
	NS30LADM	3.05	61	71	242	84	2.88	RSCR	P220MD	4TM174TFB		3/400	180	6.4	
	NS36LADM	3.58	79	92	314	95	3.30	RSCR	P220MD	4TM174TFB		4/400	180	6.4	
	NSA30LADG	3.05	70	81	278	93	2.99	RSIR	P220MC	4TM158RFB			180	6.4	
	NSB24LADG	2.42	55	64	218	72	3.03	RSIR	P220MC	4TM104RFB			180	6.4	
	NSB30LADM	3.05	77	90	306	85	3.60	RSCR	P330MD	4TM149NFB		3/400	180	6.4	
	NSB36LADG	3.58	91	106	361	104	3.60	RSIR	P220MC	4TM174TFB			180	6.4	
NSB36LADM	3.58	91	106	361	98	3.80	RSCR	P220MD	4TM174TFB		4/400	180	6.4		



TS series & NS series

Application

Small size refrigerator, freezer & water dispenser

Specifications

LBP 50-60Hz

Voltage/ Frequency	Model	Disp. (cc/rev)	Ashrae					Motor Type	ELECTRICAL PARTS				Oil Charge (cc)	Net Weight (kg)	Development
			Capacity (-23.3°C)			Consumption Power (w)	EER (Btu/wh)		Starting Device	Motor Protector	Capacitor				
			kcal/h	w	Btu/h						Starting (MFD/VAC)	Running (MFD/VAC)			
100/50-60	TS24LAAG	2.44	48	56	191	73	2.61	RSIR	P3R9MC	4TM265RFB			160	5.3	
	TS24LHAG	2.44	48	56	191	73	2.61	RSIR	QP2-3R9MC	4TM232TFB DRB26T61A1			160	6.1	
	NS24LBAG	2.42	43	50	171	68	2.51	RSIR	P3R9MC	4TM265MFB			180	6.4	
	NS30LAAG	3.05	64	74	254	87	2.92	RSIR	P3R9MC	4TM276TFB			180	6.4	
	NS36LAAM	3.58	78	91	310	91	3.40	RSCR	P3R9MD	4TM265RFB	14/220		180	6.4	
	NS36LBAG	3.58	79	92	314	98	3.20	RSIR	P6R8MC	4TM734UFB			180	6.4	
	NS36LBAM	3.58	79	92	314	93	3.37	RSCR	P6R8MD	4TM734UFB	10/220		180	6.4	
	NSA30LAAG	3.05	70	81	278	88	3.16	RSIR	P3R9MC	4TM276TFB			180	6.4	
220/50-60	NSB36LAAM	3.58	90	105	357	94	3.80	RSCR	P3R9MD	4TM265RFB	14/220		180	6.4	
	NS24LABG	2.42	43	50	171	72	2.37	RSIR	P330MC	4TM149NFB			180	5.8	
	NS30LABG	3.05	61	71	242	88	2.75	RSIR	P220MC	4TM158RFB			180	6.4	
	NS36LABG	3.58	79	92	314	98	3.20	RSIR	P220MC	4TM174TFB			180	6.4	
220-240/50-60	NS30LHBG	3.05	50	43	197	85	2.31	RSIR	220MC	4TM174TFB			180	7.3	☉
	TS24LATG	2.44	48	56	191	72	2.60	RSIR	P330MC	4TM149NFB			160	5.3	
	NS24LATG	2.42	43	50	171	75	2.28	RSIR	P330MC	4TM149NFB			180	5.8	

* Dual Frequency Performance Criteria : 60Hz

LBP 50Hz

Voltage/ Frequency	Model	Disp. (cc/rev)	Ashrae					Motor Type	ELECTRICAL PARTS				Oil Charge (cc)	Net Weight (kg)	Development
			Capacity (-23.3°C)			Consumption Power (w)	EER (Btu/wh)		Starting Device	Motor Protector	Capacitor				
			kcal/h	w	Btu/h						Starting (MFD/VAC)	Running (MFD/VAC)			
220/50	TS24LHJG	2.44	38	44	151	76	1.99	RSIR	QP2-22MC	4TM149NFB DRB16N61A1			160	6.1	
	NS30LAJG	3.05	55	64	218	93	2.35	RSIR	P330MC	4TM174TFB			180	6.4	
	NS36LAJG	3.58	63	73	250	95	2.63	RSIR	P220MC	4TM174TFB			180	6.4	
	NSA43LAJG	4.29	85	99	337	109	3.10	RSIR	P220MC	4TM205RFB			180	6.9	
220-240/50	NS24LAEG	2.42	38	44	151	76	1.99	RSIR	P220MC	4TM117SFB			180	5.8	
	NS24LBEG	2.42	36	42	143	64	2.23	RSIR	P330MC	4TM117SFB			180	6.4	
	NS30LAEG	3.05	54	63	214	81	2.65	RSIR	P330MC	4TM149NFB			180	6.4	
	NS30LAEM	3.05	53	62	210	79	2.70	RSCR	P330MD	4TM149NFB			180	6.4	
	NS36LAEG	3.58	66	77	262	89	2.94	RSIR	P220MC	4TM149NFB			180	6.4	
	NSA30LAEG	3.05	61	71	242	81	2.99	RSIR	P330MC	4TM149NFB			180	6.4	
	NSA30LAEM	3.05	61	71	242	77	3.15	RSCR	P330MD	4TM149NFB			180	6.4	
	NSA36LAEG	3.58	72	84	286	92	3.11	RSIR	P330MC	4TM149NFB			180	6.4	
	NSA43LAEG	4.29	85	99	337	102	3.31	RSIR	P220MC	4TM166RFB			180	6.9	
	NSA43LAEM	4.29	85	99	337	99	3.41	RSCR	P220MD	4TM166RFB			180	6.9	
	NSB24LAEG	2.42	39	45	155	57	2.72	RSIR	P330MC	4TM104RFB			180	5.8	
	NSB30LAEG	3.05	58	67	230	74	3.10	RSIR	P330MC	4TM149NFB			180	6.4	
		NSB30LBEM	3.05	58	67	230	68	3.39	RSCR	P330MD	4TM104KFB			180	6.4

HBP 50, 60Hz

Voltage/ Frequency	Model	Disp. (cc/rev)	Ashrae					Motor Type	ELECTRICAL PARTS				Oil Charge (cc)	Net Weight (kg)	Development
			Capacity (-23.3°C)			Consumption Power (w)	EER (Btu/wh)		Starting Device	Motor Protector	Capacitor				
			kcal/h	w	Btu/h						Starting (MFD/VAC)	Running (MFD/VAC)			
110-115/60	NS36HAQG	3.58	319	371	1266	210	6.03	RSIR	P6R8MC	RA12057-9010			180	6.4	
220/60	NS24HADG	2.42	230	267	913	140	6.50	RSIR	P220MC	4TM166RFB			180	6.4	
	NS30HADG	3.05	290	337	1151	174	6.60	RSIR	P220MC	4TM213SFB			180	6.4	
100/50-60	NS24HAAG	2.42	190	221	754	145	5.20	RSIR	P220MC	4TM706RFB			180	6.4	
	NS36HAAG	3.58	332	386	1318	211	6.25	RSIR	P3R9MC	4TM758UFB			180	6.4	
220/50-60	NS36HABG	3.58	320	372	1270	212	6.00	RSIR	P220MC	4TM232VFB			180	6.4	
220-240/50	NS24HAEG	2.42	190	221	754	145	5.20	RSIR	P220MC	4TM706RFB			180	6.4	
	NS36HAEG	3.58	268	312	1064	178	5.98	RSIR	P330MC	4TM205RFB			180	6.4	
	NS36HAEP	3.58	290	337	1151	185	6.22	CSIR	MTRP0032-15	4TM205RFB			180	6.4	



TS series & NS series

Application

Small size refrigerator, freezer & water dispenser

Compressor Dimension

(Unit : mm)

TS series

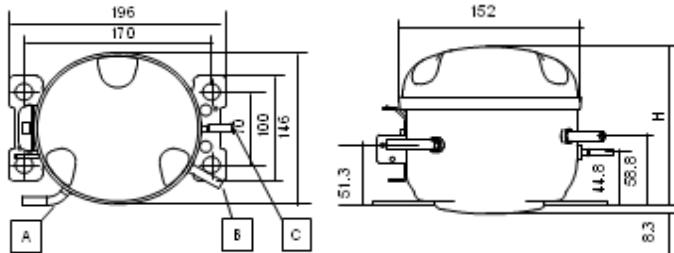

Series	H	A		B		C	
		Suction		Process		Discharge	
		I.D	T	I.D	T	I.D	T
TS24	136.5	6.54	0.7	6.54	0.7	5.0	0.85
TS24LH	150.8						

NS series

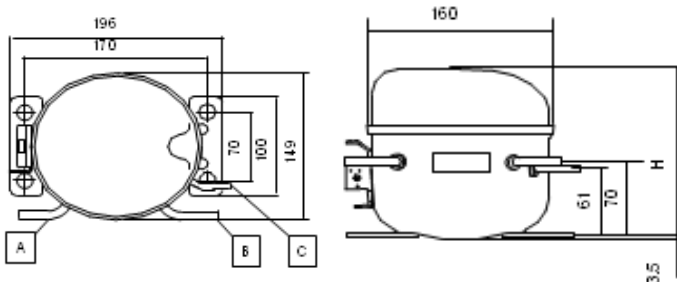

Series	H	A		B		C	
		Suction		Process		Discharge	
		I.D	T	I.D	T	I.D	T
NS(A)24	147	6.54	0.7	6.54	0.7	5.0	0.85
NS(A)30		6.14	0.9	6.14	0.9		
NS(A)36/43	157						

Mountings

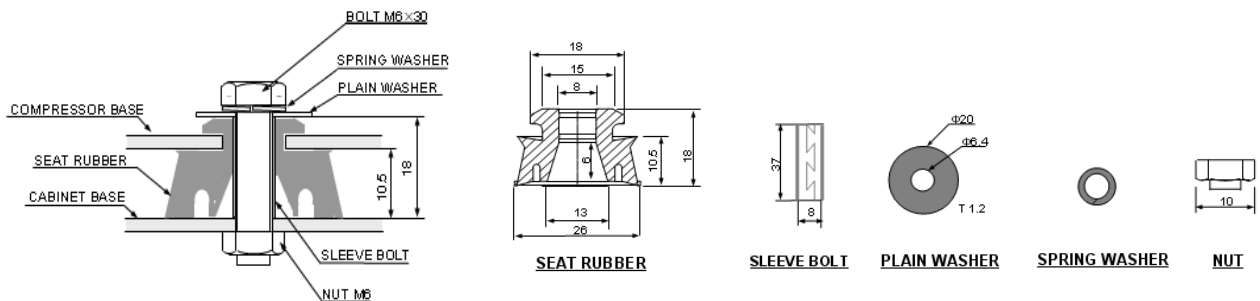



Wiring Diagram

LGE Hermetic Compressor for Refrigeration

RSIR

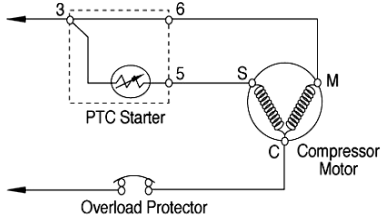
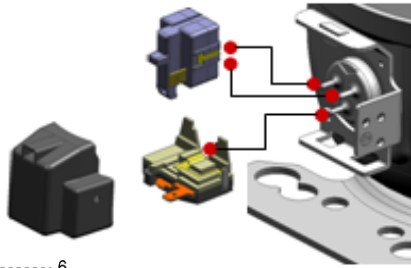

RSCR

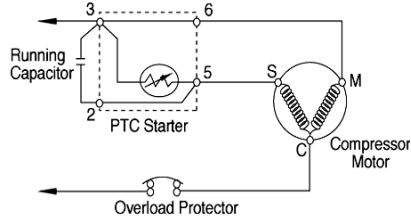
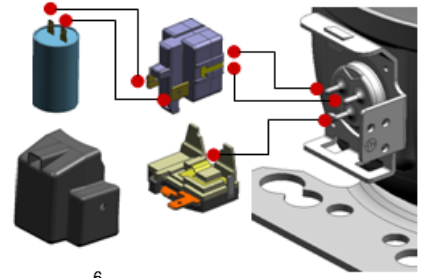

CSIR

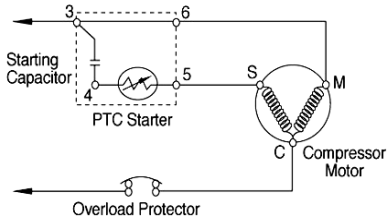
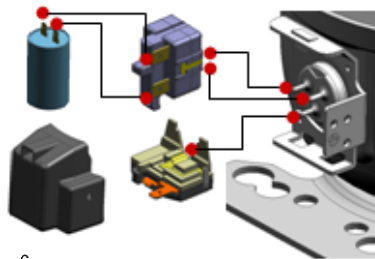

CSR

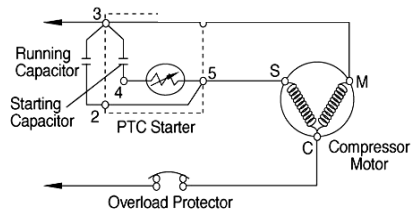
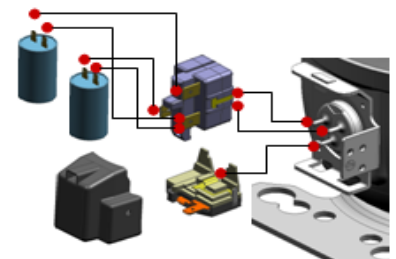

CSIR (Relay)

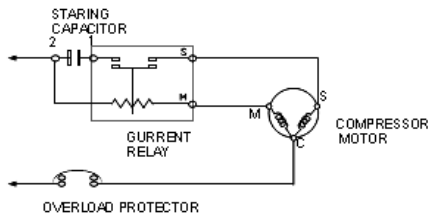
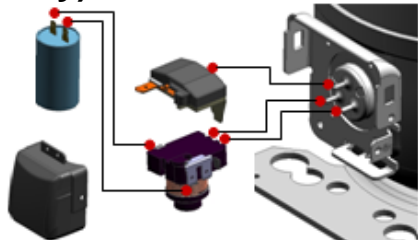

RSCR (Terminal Board)

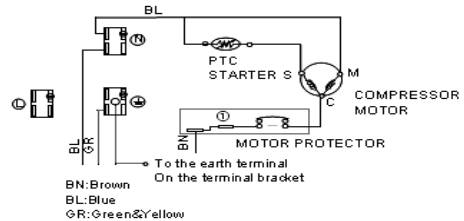
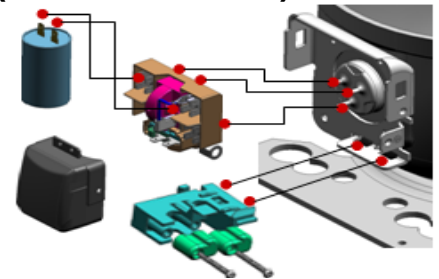



Packing Information

LGE Hermetic Compressor for Refrigeration

Carton dimension & Packing method

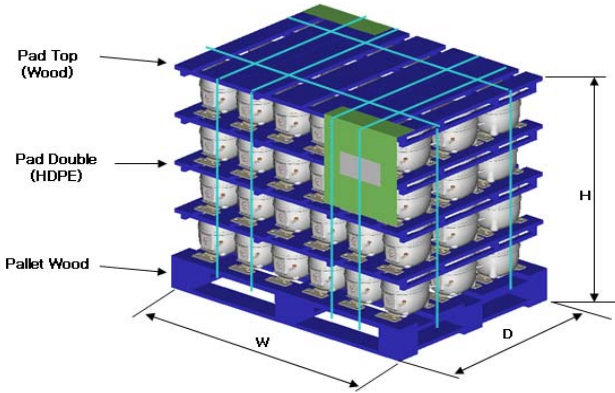

20ft Container

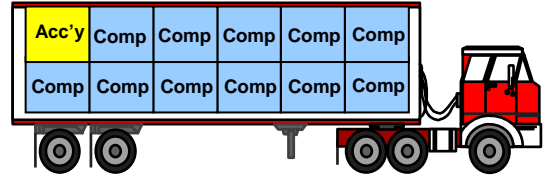

Model	Carton					Container (Below 15.3Ton)		Container (Below 17.5Ton)	
	Q'ty	Array	Dimension			Q'ty	CNTR	Q'ty	CNTR
	(EA)	(WxDxH)	W	D	H	(EA)	Weight(kg)	(EA)	Weight(kg)
TS24	150	(5X5X6)	1,100	800	1,046	2,700	15,540	3,000	17,200
TS24 (35mm)	125	(5X5X5)	1,100	800	1,046	2,375	15,088	2,750	17,375
NS24,NSA24,NSB24 NS30LAEG	125	(5X5X5)	1,100	800	950	2,375	15,325	2,750	17,650
NS30/36,NSA30/36 NSB30/36.NS24LB	125	(5X5X5)	1,100	800	1,000	2,125	15,050	2,500	17,600
NSA43,NSB43	125	(5X5X5)	1,100	800	1,015	2,000	15,200	2,250	17,025
SQ	125	(5X5X5)	1,100	800	1,060	2,000	15,400	2,250	17,250
MA53LADG	72	(3X6X4)	1,100	800	876	1,584	15,164	1,800	17,150
MA53LABM,LADM,LAUG,LCDG, MA57LAFM	72	(3X6X4)	1,100	800	876	1,512	15,258	1,728	17,352
MA53LACM,LCCM,LAAM MA57LABM,LACM.LADG.LAEG.LAQF	72	(3X6X4)	1,100	800	916	1,440	15,136	1,656	17,316
MB82NAEM,98NAAH,EM MA62LACH.CG.72PDP	72	(3X6X4)	1,100	800	916	1,440	15,424	1,656	17,648
MB53LADM,MB57LADM	72	(3X6X4)	1,100	800	916	1,368	15,093	1,584	17,382
MQ,MF, MQV	72	(3X6X4)	1,100	800	916	1,368	15,504	1,584	17,857
LX67/72, LX67/72	64	(4X4X4)	1,100	800	997	1,280	15,552	1,408	17,047
LX86/95/110/125	64	(4X4X4)	1,100	800	1,012	1,216	15,169	1,408	17,470
LA62/72/80/95	64	(4X4X4)	1,100	800	1,012	1,216	14,926	1,408	17,188
LQ,LF	64	(4X4X4)	1,100	800	1,024	1,216	15,412	1,408	17,751
FC	60	(3X5X4)	1,100	800	1,030	1,200	13,380	1,200	13,380
FM	64	(4X4X4)	1,100	800	1,030	1,280	11,460	1,280	11,460



Application

LGE Hermetic Compressor for Refrigeration

Appli.	Ambient Temperature	Evaporating Temperature	Condensing Temperature	Sub cooled Liquid Temp Expansion Device	Suction Gas Temperature	Suction Pressure				Discharge Pressure			
						R134a		R600a		R134a		R600a	
						kg/cm ² (g)	Psi(g)	kg/cm ² (g)	Psi(g)	kg/cm ² (g)	Psi(g)	kg/cm ² (g)	Psi(g)
LBP	32	-23.3	54.4	32	32	0.14	1.99	-0.389	-5.53	13.96	198.55	6.726	95.66
HBP	35	7.2	54.4	32	35	2.82	40.1	-	-	13.96	198.55	-	-

Evaporating Temperature Range	
LBP	-30 to -5°C
HBP	-5 to +15°C

* Envelope is only for LBP application.

A : Stabilized Condition
 B : Transition Running
 C : Peak Condition

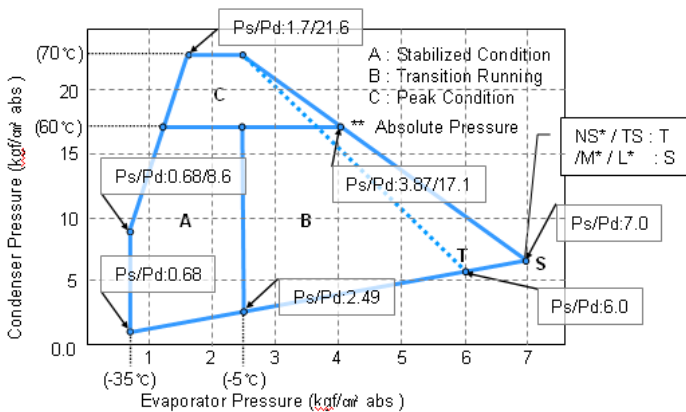

R134a

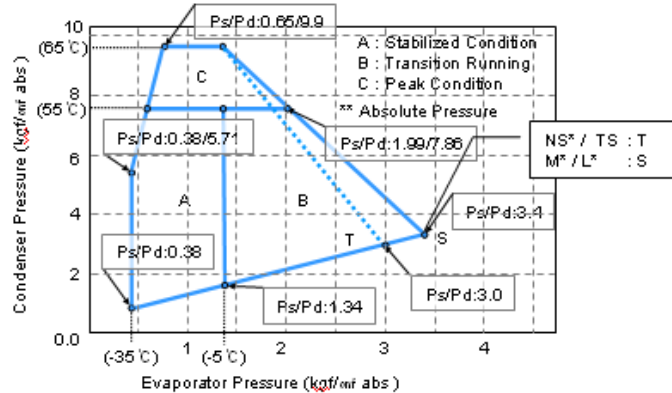

R600a

Safety

⚠ WARNING



Install the refrigerant, lubricant oil and electrical component (Capacitor and Controller) specified by compressor manufacturer.
 It can cause fire or electrical shock.



Connect the electrical wiring correctly in accordance with manufacturer's instruction.
 It can cause fire or electrical shock.



Compressor must be grounded whenever power is supplied.
 It can cause electrical shock.



Before servicing, always remove the power plug from the outlet.
 It can cause electrical shock.



Before welding, always remove refrigerant in the compressor. Do not operate compressor in the air or vacuum status.
 It can cause explosion.



Do not touch the compressor with bare hands during operation or after stopping instantly.
 It can cause get burnt.



Compressor Designation

LGE Hermetic Compressor for Refrigeration



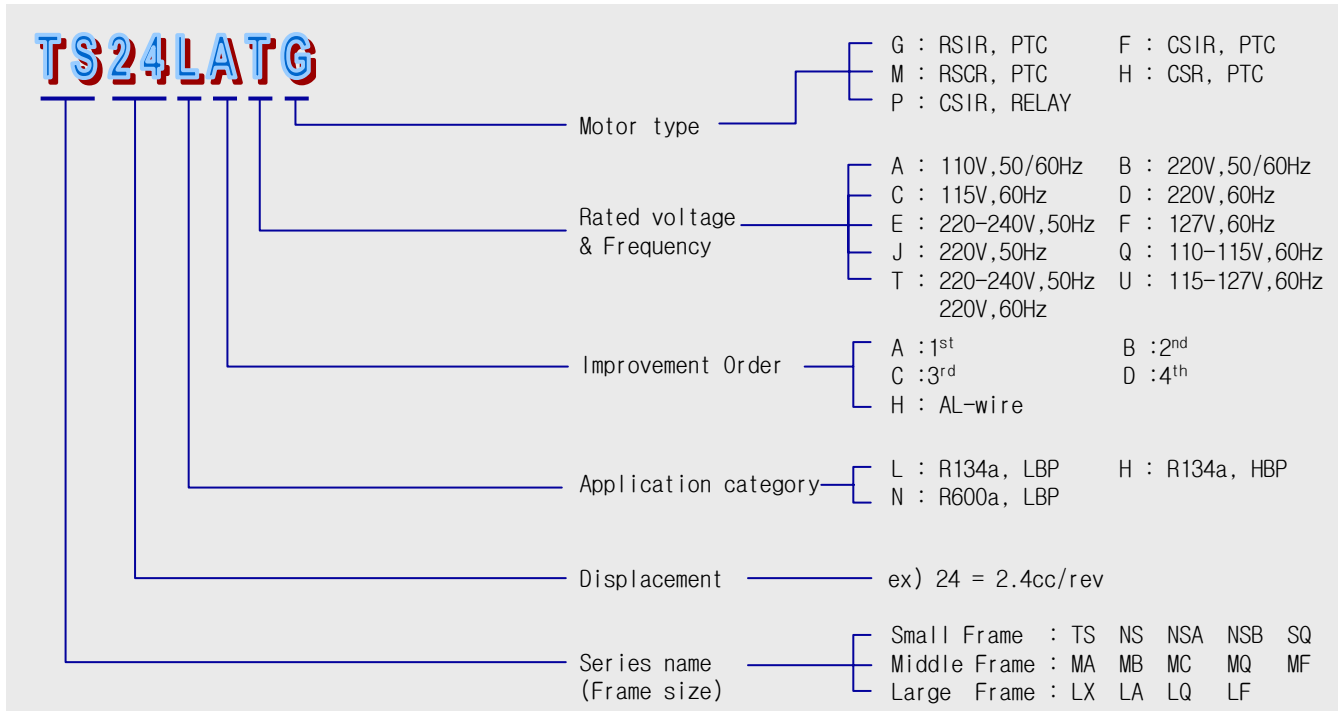

Compressor name code

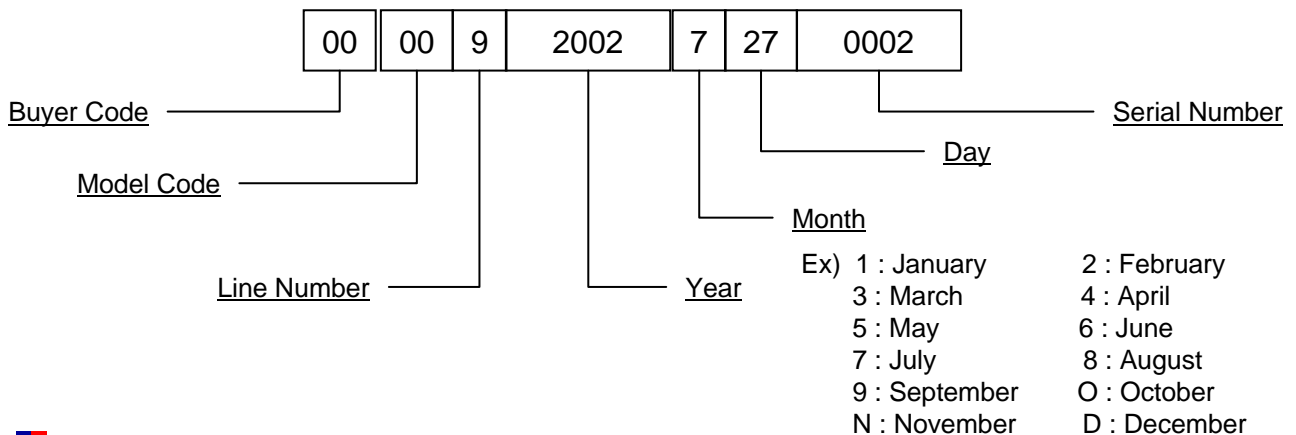

Serial number



Safety approval

			
VDE approved model	UL approved model	CSA approved model	CCC approved model

SA6269 LR41087 B370019

LG Refrigeration Compressor

MQ/MF , LQ/LF



Compressor & Motor Division



LG Electronics / Home Appliance Company

※ The numerical values shown in this material have been obtained based on current model.
They might be changed or modified by mutual agreement with customer in the future



MQ, MF, LQ, LF

Application

Middle & Large size refrigerator, freezer & Showcase

Specifications

R134a LBP 50Hz

Voltage/ Frequency	Model	Disp. (cc/rev)	PERFORMANCE									Motor Type	ELECTRICAL PARTS				Oil Charge (cc)	Net Weight (kg)	Developme nt	
			ASHRAE					CEC/MF					Starting Device	Motor Protector	Capacitor					
			Capacity (-23.3°C)			Consumption Power (w)	COP (w/w)	Capacity (-25°C)			Consumption Power (w)				COP (w/w)	Starting (MFD/VAC)				Running (MFD/VAC)
			kcal/h	w	Btu/h			kcal/h	w	Btu/h										
220/240/50	MQ53LAEM	53	173	201	687	116	1.73					RSCR	P330MD	4TM1741FE		5400	220	10		
	MQ57LAEM	57	190	221	754	128	1.7					RSCR	P330MD	4TM1741FE		5400	220	10		
	LQ62LAEM	62	199	185	631	109	1.70					RSCR	330MD2	4TM1687FE		5400	310	12		
	LQ66LAEM	86	240	279	953	161	1.7					RSCR	P470MD	4TM2637FE		5400	310	12		
	LQ68LDEM	86	240	279	953	169	1.65					RSCR				310	12			
220/50	LQ100LAUH	100	278	323	1104	201	1.6					CSR	P470MB	4TM2761FE	30300	5400	310	12		
220/240/50	MQ68NAEMe	98	117	136	538	92	1.47	155	180	615	96	1.87	RSCR	PIH1M680MD	4TM1741FE		4400	220	10	standard/plc/ e-plc
	LQ119NAEMe	119	148	172	683	117	1.5	197	229	781	122	1.87	RSCR	PIH1M680MD	4TM1687FE		5400	310	12	standard/plc/ e-plc
	LQ140NAEMe	140	171	198	788	135	1.47	227	264	901	141	1.87	RSCR	PIH1M680MD	4TM2637FE		5400	310	12	standard/plc/ e-plc

R134a LBP 50-60Hz

Voltage/ Frequency	Model	Disp. (cc/rev)	PERFORMANCE									Motor Type	ELECTRICAL PARTS				Oil Charge (cc)	Net Weight (kg)	Developme nt	
			ASHRAE					CEC/MF					Starting Device	Motor Protector	Capacitor					
			Capacity (-23.3°C)			Consumption Power (w)	COP (w/w)	Capacity (-25°C)			Consumption Power (w)				COP (w/w)	Starting (MFD/VAC)				Running (MFD/VAC)
			kcal/h	w	Btu/h			kcal/h	w	Btu/h										
100/50/60	MQ57LAAM	57	190	221	754	140	1.6	190	221	754	128	1.73	RSCR	P680MD	4TM4121FB		14220	220	10	

R134a LBP 60Hz

Voltage/ Frequency	Model	Disp. (cc/rev)	PERFORMANCE									Motor Type	ELECTRICAL PARTS				Oil Charge (cc)	Net Weight (kg)	Developme nt	
			ASHRAE					CEC/MF					Starting Device	Motor Protector	Capacitor					
			Capacity (-23.3°C)			Consumption Power (w)	COP (w/w)	Capacity (-25°C)			Consumption Power (w)				COP (w/w)	Starting (MFD/VAC)				Running (MFD/VAC)
			kcal/h	w	Btu/h			kcal/h	w	Btu/h										
220/60	MQ53LADM	50						164	191	651	111	1.71	RSCR	P330MD	4TM1741FE		5400	220	10	
	LQ62LADM	62						211	245	838	138	1.77	RSCR	330MD2	4TM2397FE		5400	310	12	
	LQ66LADM	69						241	280	957	156	1.80	RSCR	330MD2	4TM2637FE		5400	310	12	
	LQ75LADMe	75						288	312	1064	174	1.79	RSCR	PIH1M680MD	4TM4121FE		20250	310	12	standard/plc/ e-plc
115-127/60	MQ75LAUMe	50						156	181	619	104	1.74	RSCR					220	10	standard/plc/ e-plc
	MQ53LAUM	53						173	201	687	114	1.77	RSCR	P680MD	4TM2397FE		12250	220	10	
	MQ57LAUM	57						191	222	758	125	1.78	RSCR	P680MD	4TM2637FE		12250	220	10	
	LQ66LAUMe	69						241	280	957	153	1.83	RSCR	PIH1M680MD	4TM4191FE		14220	310	12	standard/plc/ e-plc
	LQ66LAUMe	69						241	280	957	153	1.83	RSCR	PIH1M680MD	4TM4191FE	100*60	14220	310	12	standard/plc/ e-plc
	LQ68LDRM	69						241	280	957	162	1.73	RSCR				14220	310	12	
	LQ75LAUMe	75						288	312	1064	174	1.79	RSCR	PIH1M680MD	4TM4121FE		20250	310	12	

* Dual Frequency Performance Criteria : 60Hz



MQ, MF, LQ, LF

Application

Middle & Large size refrigerator, freezer & Showcase

Specifications

R600a LBP 50Hz

Voltage/ Frequency	Model	Disp. (cc/rev)	PERFORMANCE									Mtr Type	ELECTRICAL PARTS				Oil Charge (cc)	Net Weight (kg)	Development	
			ASHRAE					COOLREF					Starting Device	Mtr Protector	Capacitor					
			Capacity (-23°C)			Consumption Power (w)	COP (W/W)	Capacity (-25°C)			Consumption Power (w)				COP (W/W)	Starting (MFD/VAC)				Running (MFD/VAC)
			kcal/h	w	Blu/h			kcal/h	w	Blu/h										
220-240/50	MF57NAEM	5.7	86	100	341	51	1.96	64	74	253	49	1.52	e-PTORSOR					220	10	under development
	MF62NAEM	6.2	97	113	366	57	1.99	72	84	266	54	1.55	e-PTORSOR	PIH1M220MD	4TM129KFB	-	4400	220	10	under development
	MF69NAEM	6.9	108	126	400	63	1.99	80	93	319	60	1.55	e-PTORSOR			-	-	220	10	under development
	MF82NAEM	8.2	136	153	539	80	1.98	101	117	400	76	1.54	e-PTORSOR			-	-	220	10	under development
	MF88NAEM	8.8	146	170	580	86	1.98	108	126	430	82	1.54	e-PTORSOR			-	-	220	10	under development
	MF98NAEM	9.8	162	188	642	95	1.98	120	139	475	90	1.54	e-PTORSOR	PIH1M830MD	4TM174TFB	-	4400	220	10	under development
	MF108NAEM	10.8	176	205	700	105	1.95	131	152	518	100	1.52	e-PTORSOR	PIH1M830MD	4TM174TFB	-	5400	220	10	under development
	MF57NAEM	5.7	86	100	341	53	1.90	64	74	253	50	1.48	PTORSOR			-	-	220	10	under development
	MF62NAEM	6.2	97	113	366	58	1.94	72	84	266	55	1.51	PTORSOR	P220MD	4TM129KFB	-	4400	220	10	under development
	MF69NAEM	6.9	108	126	400	65	1.94	80	93	319	62	1.51	PTORSOR			-	-	220	10	under development
	MF82NAEM	8.2	136	153	539	81	1.94	101	117	400	78	1.51	PTORSOR			-	-	220	10	under development
	MF88NAEM	8.8	146	170	580	88	1.94	108	126	430	83	1.51	PTORSOR			-	-	220	10	under development
	MF98NAEM	9.8	162	188	642	96	1.95	120	139	475	92	1.52	PTORSOR	P330MD	4TM174TFB	-	4400	220	10	under development
	MF108NAEM	10.8	176	205	700	107	1.92	131	152	518	102	1.49	PTORSOR	P330MD	4TM174TFB	-	5400	220	10	under development
	MF57NAEM	5.7	86	100	341	56	1.80	64	74	253	53	1.40	PTORSOR			-	-	220	10	under development
	MF62NAEM	6.2	97	113	366	63	1.80	72	84	266	60	1.40	PTORSOR			-	-	220	10	under development
	MF69NAEM	6.9	108	126	400	70	1.80	80	93	319	67	1.40	PTORSOR			-	-	220	10	under development
	MF82NAEM	8.2	136	153	539	88	1.80	101	117	400	84	1.40	PTORSOR			-	-	220	10	under development
	MF88NAEM	8.8	146	170	580	94	1.80	108	126	430	90	1.40	PTORSOR			-	-	220	10	under development
	MF98NAEM	9.8	162	188	642	104	1.80	120	139	475	99	1.40	PTORSOR			-	-	220	10	under development
	MF108NAEM	10.8	176	205	700	114	1.80	131	152	518	108	1.40	PTORSOR			-	-	220	10	under development
	LQ19NAEM	11.9	195	227	775	121	1.88	144	168	574	115	1.46	e-PTORSOR	PIH1M830MD	4TM168KFB	-	5400	310	12	
	LQ12NAEM	12.5	208	242	826	129	1.88	154	179	611	123	1.46	e-PTORSOR			-	-	310	12	under development
	LQ14NAEM	14.0	228	265	905	142	1.87	169	196	669	135	1.45	e-PTORSOR	PIH1M830MD	4TM268RFB	-	5400	310	12	
	LQ19NAEM	11.9	195	227	775	122	1.86	144	168	574	116	1.45	PTORSOR	P330MD	4TM168KFB	-	5400	310	12	under development
	LQ12NAEM	12.5	208	242	826	130	1.86	154	179	611	124	1.44	PTORSOR			-	-	310	12	under development
	LQ14NAEM	14.0	228	265	905	143	1.85	169	196	670	137	1.44	PTORSOR	P330MD	4TM268RFB	-	5400	310	12	under development

Mountings

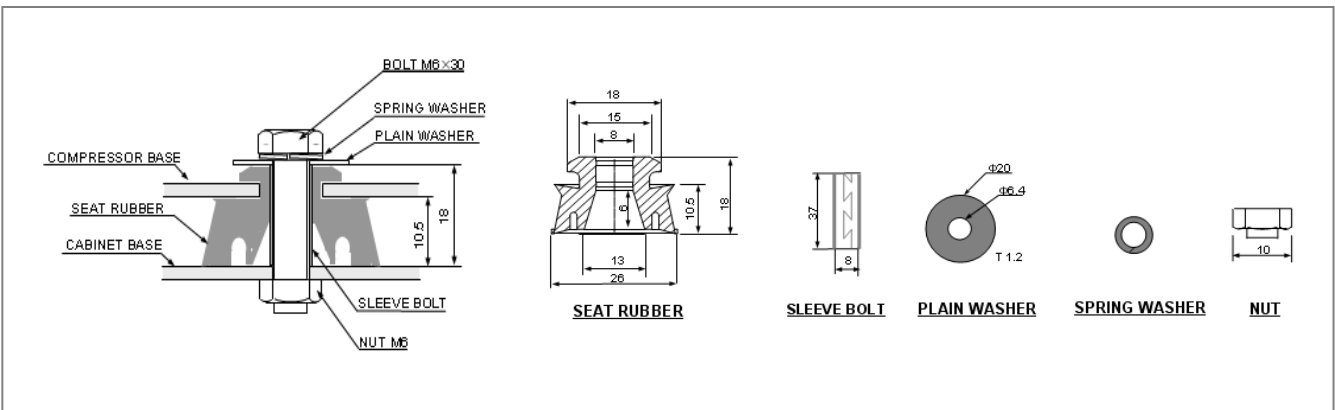

LG can accept no responsibility for possible errors in catalogues. LG reserves the right to alter its products without notice. This also applies to products already on order provided that such alterations can be made without sub sequential changes being necessary in specifications already agreed.6



MQ, MF, LQ, LF

Application

Middle & Large size refrigerator, freezer & Showcase

Compressor Dimension

(Unit : mm)

MQ / MF

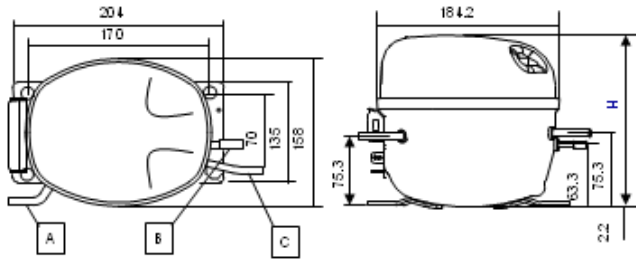

Series	H	A		B		C	
		SUCTION		DISCHARGE		PROCESS	
		ID	T	ID	T	ID	T
MQ50/53/57	182	6.14	0.7	5.0	0.85	6.14	0.7
MQ82/88/98N		6.54	0.9			6.54	0.9
MF50/53/57							
MF57/62/69/82/88/98/108N							

LQ / LF

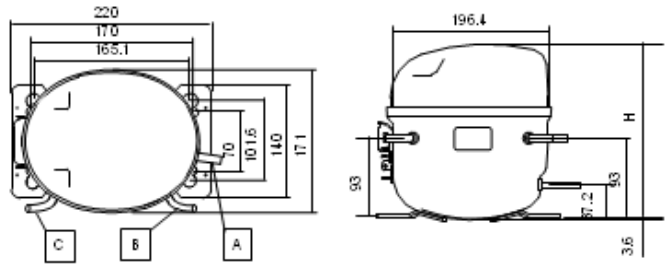

Series	H	A		B		C	
		SUCTION		DISCHARGE		PROCESS	
		ID	T	ID	T	ID	T
LQ62/69/75/86/119/125/140	203	6.14	0.7	5.0	0.85	6.14	0.7
LF50/55/62/69		6.54	0.9			6.54	0.9



Wiring Diagram

LGE Hermetic Compressor for Refrigeration

RSIR

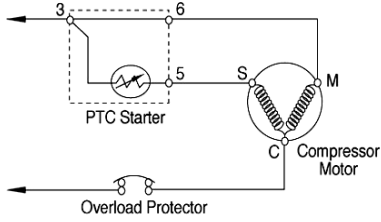
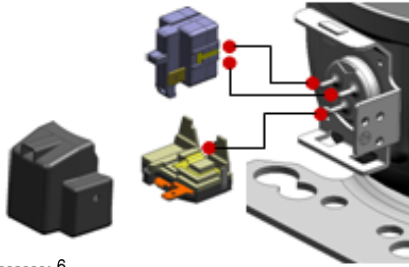

RSCR

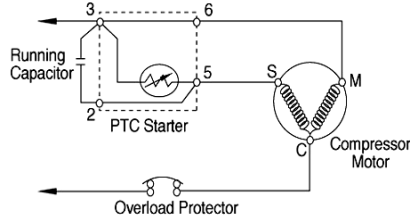
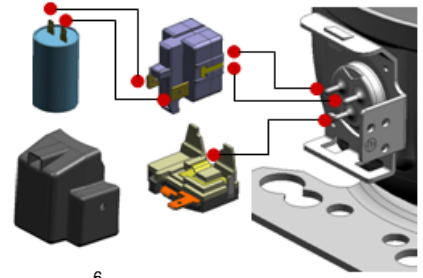

CSIR

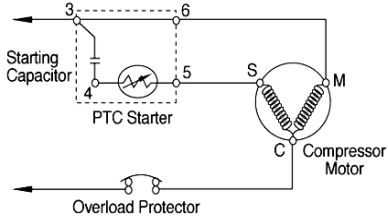
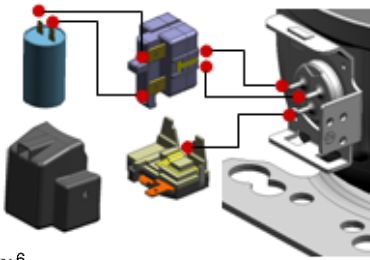

CSR

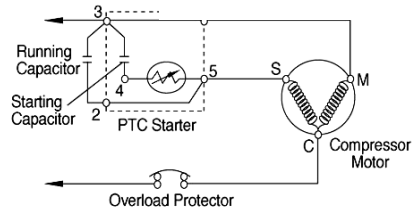
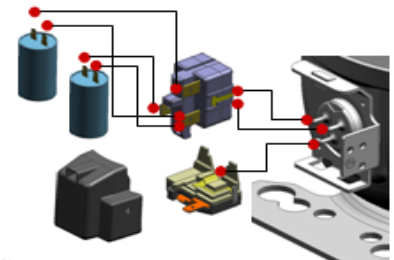

CSIR (Relay)

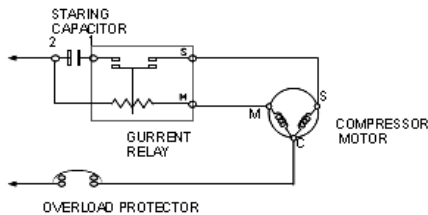
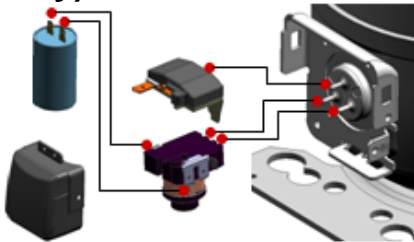

RSCR (Terminal Board)

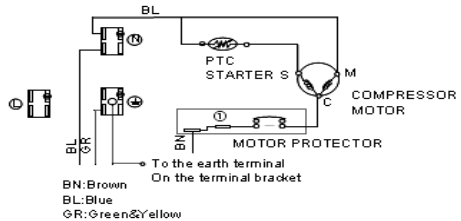
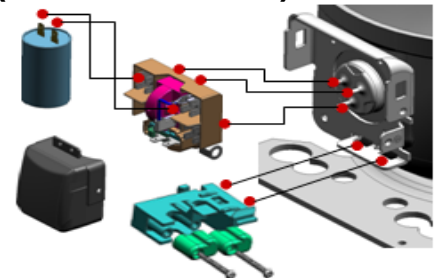



Wiring Diagram (e-ptc)

LGE Hermetic Compressor for Refrigeration

RSCR

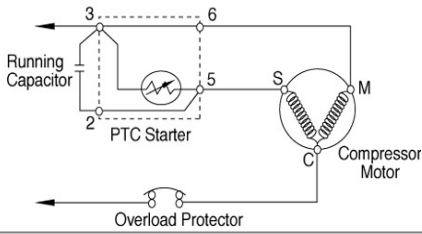
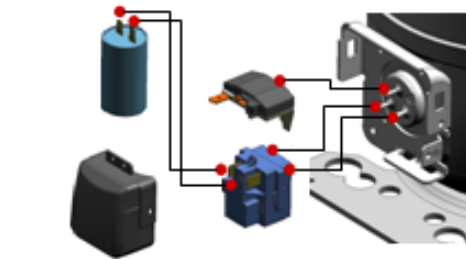



Packing Information

LGE Hermetic Compressor for Refrigeration

Carton dimension & Packing method

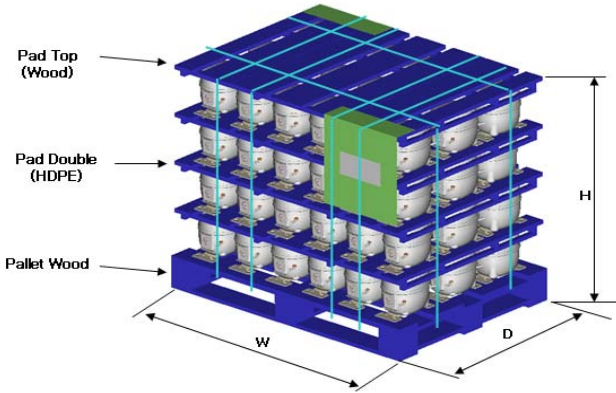

20ft Container

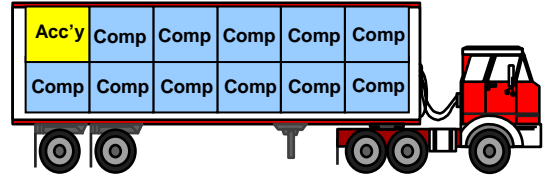

Model	Carton					Container (Below 15.3Ton)		Container (Below 17.5Ton)	
	Q'ty	Array	Dimension			Q'ty	CNTR	Q'ty	CNTR
	(EA)	(WxDxH)	W	D	H	(EA)	Weight(kg)	(EA)	Weight(kg)
TS24	150	(5X5X6)	1,100	800	1,046	2,700	15,540	3,000	17,200
TS24 (35mm)	125	(5X5X5)	1,100	800	1,046	2,375	15,088	2,750	17,375
NS24,NSA24,NSB24 NS30LAEG	125	(5X5X5)	1,100	800	950	2,375	15,325	2,750	17,650
NS30/36,NSA30/36 NSB30/36.NS24LB	125	(5X5X5)	1,100	800	1,000	2,125	15,050	2,500	17,600
NSA43,NSB43	125	(5X5X5)	1,100	800	1,015	2,000	15,200	2,250	17,025
SQ	125	(5X5X5)	1,100	800	1,060	2,000	15,400	2,250	17,250
MA53LADG	72	(3X6X4)	1,100	800	876	1,584	15,164	1,800	17,150
MA53LABM,LADM,LAUG,LCDG, MA57LAFM	72	(3X6X4)	1,100	800	876	1,512	15,258	1,728	17,352
MA53LACM,LCCM,LAAM MA57LABM,LACM.LADG.LAEG.LAQF	72	(3X6X4)	1,100	800	916	1,440	15,136	1,656	17,316
MB82NAEM,98NAAH,EM MA62LACH.CG.72PDP	72	(3X6X4)	1,100	800	916	1,440	15,424	1,656	17,648
MB53LADM,MB57LADM	72	(3X6X4)	1,100	800	916	1,368	15,093	1,584	17,382
MQ,MF, MQV	72	(3X6X4)	1,100	800	916	1,368	15,504	1,584	17,857
LX67/72, LX67/72	64	(4X4X4)	1,100	800	997	1,280	15,552	1,408	17,047
LX86/95/110/125	64	(4X4X4)	1,100	800	1,012	1,216	15,169	1,408	17,470
LA62/72/80/95	64	(4X4X4)	1,100	800	1,012	1,216	14,926	1,408	17,188
LQ,LF	64	(4X4X4)	1,100	800	1,024	1,216	15,412	1,408	17,751
FC	60	(3X5X4)	1,100	800	1,030	1,200	13,380	1,200	13,380
FM	64	(4X4X4)	1,100	800	1,030	1,280	11,460	1,280	11,460



Application

LGE Hermetic Compressor for Refrigeration

Appli.	Ambient Temperature	Evaporating Temperature	Condensing Temperature	Sub cooled Liquid Temp Expansion Device	Suction Gas Temperature	Suction Pressure				Discharge Pressure			
						R134a		R600a		R134a		R600a	
						kg/cm ² (g)	Psi(g)	kg/cm ² (g)	Psi(g)	kg/cm ² (g)	Psi(g)	kg/cm ² (g)	Psi(g)
LBP	32	-23.3	54.4	32	32	0.14	1.99	-0.389	-5.53	13.96	198.55	6.726	95.66
HBP	35	7.2	54.4	32	35	2.82	40.1	-	-	13.96	198.55	-	-

Evaporating Temperature Range	
LBP	-30 to -5°C
HBP	-5 to +15°C

* Envelope is only for LBP application.

A : Stabilized Condition
B : Transition Running
C : Peak Condition

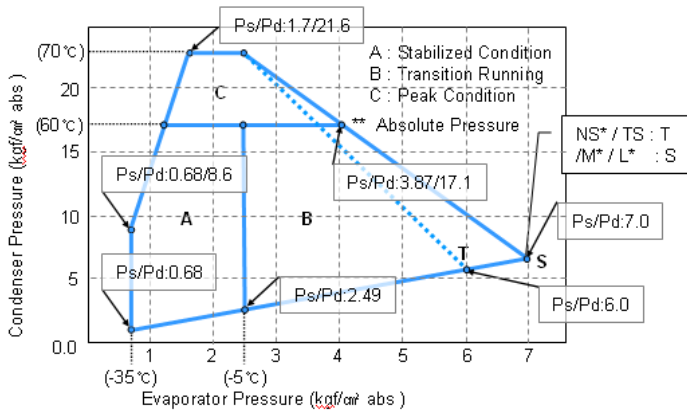

R134a

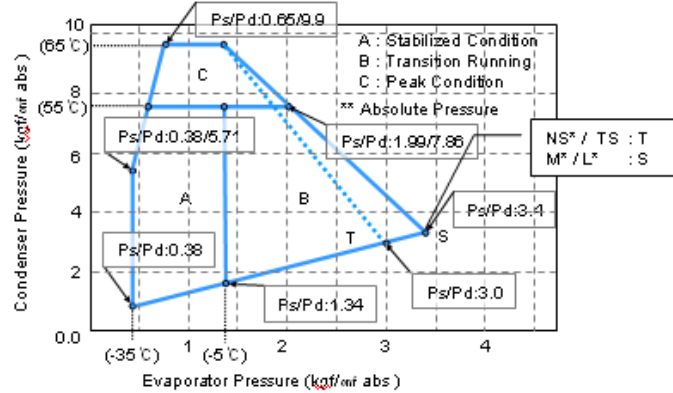

R600a

Safety

⚠ WARNING



Install the refrigerant, lubricant oil and electrical component (Capacitor and Controller) specified by compressor manufacturer.
It can cause fire or electrical shock.



Connect the electrical wiring correctly in accordance with manufacturer's instruction.
It can cause fire or electrical shock.



Compressor must be grounded whenever power is supplied.
It can cause electrical shock.



Before servicing, always remove the power plug from the outlet.
It can cause electrical shock.



Before welding, always remove refrigerant in the compressor.
Do not operate compressor in the air or vacuum status.
It can cause explosion.



Do not touch the compressor with bare hands during operation or after stopping instantly.
It can cause get burnt.



Compressor Designation

LGE Hermetic Compressor for Refrigeration

Compressor name code

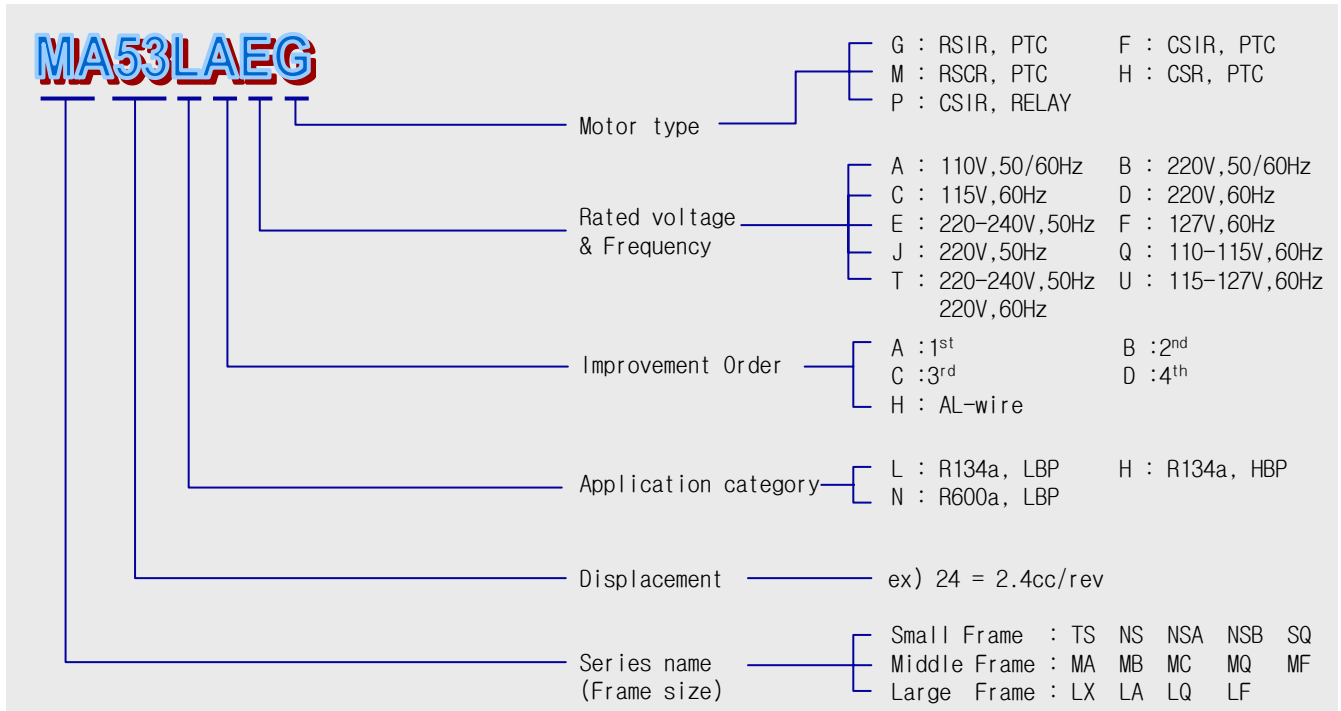

Serial number

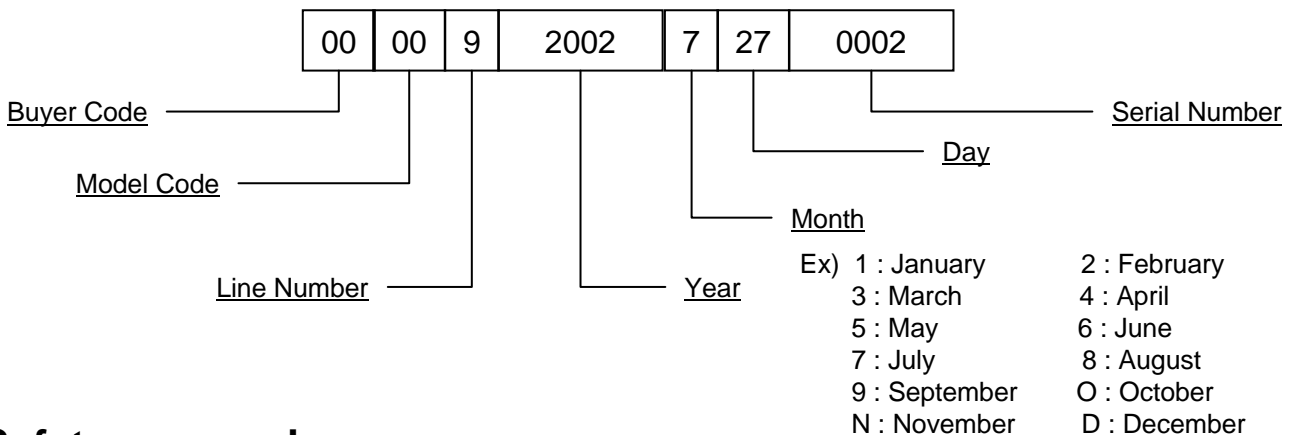

Safety approval

VDE approved model	UL approved model	CSA approved model	CCC approved model

SA6269 LR41087 B370019

LG Refrigeration Compressor

M* / L*



Compressor & Motor Division



LG Electronics / Home Appliance Company

※ The numerical values shown in this material have been obtained based on current model.
They might be changed or modified by mutual agreement with customer in the future



M series & L series

Application

Middle & Large size refrigerator, freezer & Showcase

Specifications

R134a LBP 50Hz

Voltage/ Frequency	Model	Disp. (cc/rev)	PERFORMANCE					Motor Type	ELECTRICAL PARTS				Oil Charge (cc)	Net Weight (kg)	Development
			ASHRAE						Starting Device	Motor Protector	Capacitor				
			Capacity (-23.3°C)			Consumption Power (w)	EER (Btu/wh)				Starting (MFD/VAC)	Running (MFD/VAC)			
			kcal/h	w	Btu/h										
220/50	LX72LHJF	7.22	148	172	683	180	3.80	CSIR	P330MA	4TM314UFB	30/300		310	10.9	
	LX72LHJH	7.22	148	172	683	161	4.24	CSR	P470MB, QP2-47MB3	4TM314UFB	30/300	5/400	310	10.9	
	LX72LHJM	7.22	148	172	683	161	4.24	RSCR	P330MD, QP2-33MD2	4TM314RFB		5/400	310	10.9	
	LX86LAJG	8.56	194	226	770	182	4.23	RSIR	P470MC	4TM293RFB			310	11.2	
	LX86LHJF	8.56	194	167	770	203	3.80	CSIR	P330MA	4TM314UFB		30/300	310	11.2	
	LA95LAJH	9.51	240	279	953	198	4.81	CSR	P470MB	4TM314TFB		5/400	310	11.2	
	LX110LAJH	11.03	270	314	1072	236	4.54	CSR	P470MB	4TM314TFB	30/300	5/400	310	11.2	
	LX110LAJM	11.03	270	314	1072	236	4.54	RSCR	P470MD	4TM314TFB		5/400	310	11.2	
	LX110LHJF	11.03	38	33	151	72	2.10	CSIR	P470MA	4TM743UFB	30/300		310	11.2	
	LX110LHJH	11.03	270	232	1072	249	4.30	CSR	P470MB	4TFB, DRB33	5/400	30/300	310	11.2	
220-240/50	LX125LAJM	12.54	315	366	1251	278	4.50	RSCR	P470MD	4TM412RFB		5/400	310	11.2	
	MA57LAEG	5.71	138	160	548	119	4.6	RSIR	P330MC	4TM213SFB			220	8.6	
	MA57LAEM	5.71	138	160	548	110	5	RSCR	P330MD	4TM158RFB		5/400	220	8.6	
	MA62LCEG	6.24	152	176	603	126	4.8	RSIR	P330MC	4TM213SFB			220	9.1	
	MA69LAEG	6.91	172	200	683	155	4.4	RSIR	P330MC	4TM283RFB			220	8.6	
	MC57LAEM	5.71	147	170.5	584	106	5.5	RSCR	P330MD	4TM158RFB		5/400	220	9.5	
	MC62LAEM	6.24	157	182	623	117	5.35	RSCR	P330MD	4TM174TFB		5/400	220	9.5	
	MC62LAEH	6.24	157	182	623	117	5.35	CSR	P330MB	4TM174TFB	30/300	5/400	220	9.5	
	MA57LHEM	5.71	138	118.7	548	133	4.12	RSCR	330MD2, QP2-33MD2	4TM205RFB	5/400		220	9.5	
	LX67LBEG	6.66	155	180	615	151	4.08	RSIR	P470MC	4TM276TFB			310	10.9	
	LX72LAEG	7.22	170	198	675	154	4.38	RSIR	P470MC	4TM276TFB			310	10.9	
	LX72LAEM	7.22	170	198	675	146	4.62	RSCR	P470MD	4TM265RFB		5/400	310	10.9	
	LX72LBEG	7.22	170	198	675	154	4.38	RSIR	P470MC	4TM276TFB			310	10.9	
	LX86LAEG	8.56	205	238	814	177	4.60	RSIR	P470MC	4TM276VFB			310	11.2	
	LX86LAEM	8.56	194	226	770	159	4.84	RSCR	P470MD	4TM265RFB		5/400	310	11.2	
	LX86LBEG	8.56	194	226	770	179	4.30	RSIR	P470MC	4TM276VFB			310	11.2	
	LX86LCEG	8.56	194	226	770	182	4.23	RSIR	P470MC	4TM314TFB			310	11.2	
	LX86LHEM	8.56	194	167	770	179	4.30	RSCR	P470MD2, 470MD2, QP2-47MD2	4TM232VFB	5/400		310	11.2	
	LX110LAEH	11.03	270	314	1072	215	4.99	CSR	P470MB	4TM276TFB	30/300	5/400	310	11.2	
	LX110LAEM	11.03	270	314	1072	215	4.99	RSCR	P470MD	4TM276TFB		5/400	310	11.2	
LA62LAEM	6.23	145	169	576	113	5.16	RSCR	P330MD	4TM232NFB		5/400	310	10.9		
LA72LAEM	7.22	177	206	703	135	5.20	RSCR	P330MD	4TM232NFB		4/400	310	10.9		
LA95LAEM	9.51	240	279	953	181	5.25	RSCR	P470MD	4TM265RFB		4/400	310	11.2		

R134a LBP 50-60Hz

Voltage/ Frequency	Model	Disp. (cc/rev)	PERFORMANCE					Motor Type	ELECTRICAL PARTS				Oil Charge (cc)	Net Weight (kg)	Development
			ASHRAE						Starting Device	Motor Protector	Capacitor				
			Capacity (-23.3°C)			Consumption Power (w)	EER (Btu/wh)				Starting (MFD/VAC)	Running (MFD/VAC)			
			kcal/h	w	Btu/h										
100/50-60	MA57LAAM	5.71	171	199	679	133	5.1	RSCR	P6R8MD	4TM314TFB		10/220	220	8.6	
	MA62LCAH	6.24	184	214	730	138	5.3	CSR	P6R8MB	4TM414KFB	100/160	14/220	220	8.6	
	LX72LAAM	7.22	213	248	846	180	4.70	RSCR	P6R8MD	4TM444RFB		14/220	310	10.9	
	LX95LAAH	9.51	280	326	1112	227	4.90	CSR	P6R8MB	4TM777VFB	100/160	14/220	310	11.2	
	LX110LAAH	11.03	300	349	1191	255	4.67	CSR	P6R8MB	4TM795VFB	100/160	14/250	310	11.2	
	MA53LABM	5.25	154	179.1	611	125	4.9	RSCR	P330MD	4TM232NFB		5/400	220	8.3	
220/50-60	MA53LABG	5.25	152	176.7	603	131	4.6	RSIR	P330MC	4TM232NFB			220	8.3	
	MA57LABM	5.71	171	199	679	128	5.3	RSCR	P330MD	4TM213SFB		5/400	220	8.6	
	LX67LABM	6.66	195	227	774	152	5.09	RSCR	P470MD	4TM265RFB		5/400	310	10.9	
	LX67LABH	6.66	196	228	778	158	4.93	CSR	P470MD	4TM265RFB		3/400	310	10.9	
	LX67LHBM	6.66	195	168	774	161	4.81	RSCR	QP2-33MD2, 330MD2	4TM232TFB	5/400		310	10.9	
	LX72LPBP	7.22	206	240	818	180	4.54	CSIR	MTRP0040-15	4TM734UFB	30/300		310	10.9	
	LX86LABM	8.56	250	291	993	193	5.14	RSCR	P470MD	4TM293RFB		4/400	310	11.2	
	LX86LPBP	8.56	247	287	981	218	4.50	CSIR	MTRP0058-15	4TM743UFB	30/300		310	11.2	
	LX95LABH	9.51	280	326	1112	224	4.96	CSR	P470MB	4TM314TFB	30/300	5/400	310	11.2	
	LX72LATG	7.22	213	248	846	181	4.67	RSIR	P470MC	4TM314TFB			310	10.9	
220-240/50-60	LX72LATF	7.22	213	248	846	181	4.67	CSIR	P470MA	4TM314TFB	30/300		310	10.9	
	LX72LATH	7.22	213	248	846	175	4.83	CSR	P470MB	4TM276TFB		3/400	310	10.9	

* Dual Frequency Performance Criteria : 60Hz

LG can accept no responsibility for possible errors in catalogues. LG reserves the right to alter its products without notice. This also applies to products already on order provided that such alterations can be made without sub sequential changes being necessary in specifications already agreed.



M series & L series

Application

Middle & Large size refrigerator, freezer & Showcase

Specifications

R134a LBP 60Hz

Voltage/ Frequency	Model	Disp. (cc/rev)	PERFORMANCE					Motor Type	ELECTRICAL PARTS				Oil Charge (cc)	Net Weight (kg)	Development	
			ASHRAE			Consumption Power (w)	EER (Btu/wh)		Starting Device	Motor Protector	Capacitor					
			Capacity (-23.3°C)								Starting (MFD/VAC)	Running (MFD/VAC)				
kcal/h	w	Btu/h														
110-115/60	LX67LAQG	6.66	187	217	742	177	4.19	RSIR	P6R8MC	4TM445VFB			310	10.9		
	LX67LAQM	6.66	195	227	774	166	4.65	RSCR	P6R8MB	4TM419TFB		14/220	310	10.9		
	LX72LBQG	7.22	213	248	846	198	4.27	RSIR	P6R8MC	4TM444UFB			310	10.9		
	LX72LBQM	7.22	213	248	846	181	4.67	RSCR	P6R8MD	4TM444UFB			310	10.9		
	LX72LHQF	7.22	213	183	846	216	3.91	CSIR	6R8MA2	4TM445VFB		100/160	310	10.9		
	LX86LAQM	8.56	245	285	973	198	4.91	RSCR	P6R8MD	4TM412RFB		14/220	310	11.2		
	LX95LAQH	9.51	280	326	1112	222	5.01	CSR	P220MB	4TM444RFB	100/160	10/250	310	11.2		
	LX95LBQH	9.51	280	326	1112	240	4.63	CSR	P220MB	4TM445VFB	100/160	10/250	310	11.2		
	LA80LAQH	7.95	245	285	973	203	4.80	CSR	P6R8MB	4TM445VFB	100/160	14/250	310	11.2		
	LA80LBQH	7.95	252	293	1000	184	5.45	CSR	P6R8MB	4TM412TFB	100/160	14/250	310	11.2		
LA95LAQH	9.51	312	363	1239	233	5.10	CSR	P150MB	4TM777VFB	100/160	14/220	310	11.2			
115-127/60	MA53LGUG	5.25	150	129	596	135	4.40	RSIR	P6R8MC	4TM427TFB						
	LX67LAFM	6.66	195	227	774	153	5.06	RSCR	P220MD	4TM412TFB		14/220	310	10.9		
	LX86LAFH	8.56	250	291	993	208	4.77	CSR	P6R8MB	4TM444RFB	100/160	14/250	310	11.2		
	LX95LAFH	9.51	280	326	1112	232	4.79	CSR	P220MB	4TM444UFB	100/160	10/250	310	11.2		
	LA86LAFH	8.56	272	316	1080	212	5.10	CSR	P6R8MB	4TM444UFB	100/160	14/220	310	11.2		
115/60	MA53LACM	5.25	154	179	611	119	5.2	RSCR	P6R8MD	4TM314TFB		15/220	220	8.6		
	MA53LCCM	5.25	155	180.2	615	116	5.3	RSCR	P6R8MD	4TM314TFB		12/220	220	8.6		
	MA57LACM	5.71	171	199	679	128	5.3	RSCR	P6R8MD	4TM314TFB		15/220	220	8.6		
	MA62LACM	6.24	184	214	730	138	5.3	RSCR	P6R8MD	4TM314TFB		14/220	220	8.6		
	MB53LACH	5.25	156	181.4	619	113	5.5	CSR	P6R8MB	4TM414KFB	100/160	12/220	220	9.5		
	MB53LBCH	5.25	156	181	619	115	5.4	CSR	P6R8MB	4TM414KFB	100/160	12/250	220	9.5		
	LX86LACM	8.56	245	285	973	198	4.91	RSCR	P6R8MD	4TM412RFB		14/220	310	11.2		
	LA62LACM	6.23	188	219	746	138	5.40	RSCR	P6R8MD	4TM412RFB		15/210	310	10.9		
	LA62LBCM	6.23	188	219	746	142	5.25	RSCR	P6R8MD	4TM414KFB		12/250	310	10.9		
	LA67LACM	6.66	209	243	830	154	5.40	RSCR	P6R8MD	4TM412RFB		12/250	310	10.9		
	LA67LBCM	6.66	210	244	834	152	5.50	RSCR	P6R8MD	4TM412RFB		15/210	310	10.9		
	LA80LACM	7.95	268	312	1064	165	6.45	RSCR	P6R8MD	4TM412RFB		12/250	310	11.2		
	LA80LACH	7.95	249	290	989	183	5.40	CSR	P6R8MB	4TM412TFB	100/160	14/250	310	11.2		
	LA86LACH	8.56	270	314	1072	202	5.30	CSR	P6R8MB	4TM444RFB	100/160	14/220	310	11.2		
127/60	LX67LAFM	6.66	195	227	774	153	5.06	RSCR	P220MD	4TM412TFB		14/220	310	10.9		
	LX86LAFH	8.56	250	291	993	208	4.77	CSR	P6R8MB	4TM444RFB	100/160	14/250	310	11.2		
	LX95LAFH	9.51	280	326	1112	232	4.79	CSR	P220MB	4TM444UFB	100/160	10/250	310	11.2		
	LA86LAFH	8.56	272	316	1080	212	5.10	CSR	P6R8MB	4TM444UFB	100/160	14/220	310	11.2		
220/60	MA53LADG	5.25	152	176.7	603	134	4.5	RSCR	P330MC	4TM232NFB			220	7.9		
	MA53LADM	5.25	154	179.1	611	125	4.9	RSCR	P330MD	4TM232NFB		5/400	220	8.3		
	MA53LBDM	5.25	153	177.9	607	129	4.7	RSCR	P330MD	4TM232NFB		5/400	220	8.3		
	MA57LADM	5.71	171	199	679	128	5.3	RSCR	P330MD	4TM213SFB		5/400	220	8.6		
	MA57LADG	5.71	168	195.3	667	142	4.7	RSIR	P330MC	4TM213SFB			220	8.6		
	MA62LADM	6.24	184	214	730	138	5.3	RSCR	P330MD	4TM213SFB		5/400	220	8.6		
	MB53LADM	5.25	156	181	619	115	5.4	RSCR	P330MD	4TM158RFB		5/400	220	9.5		
	MB57LADM	5.71	171	198.8	679	121	5.6	RSCR	P330MD	4TM174TFB		5/400	220	9.5		
	MA72LADP	7.2	200	172	794	198	4.00		QL2-4.25B3	4TM734UFB		30/300	220	9.5		
	MA72LHDM	7.2	205	176.3	814	238	4.20	RSIR								
	LX67LADG	6.66	195	227	774	168	4.61	RSIR	P470MC	4TM265RFB			310	10.9		
	LX72LADM	7.22	213	248	846	169	5.00	RSCR	P470MD	4TM265RFB		4/400	310	10.9		
	LX86LADM	8.56	250	291	993	193	5.14	RSCR	P470MD	4TM293RFB		4/400	310	11.2		
	LX95LADH	9.51	280	326	1112	224	4.96	CSR	P470MB	4TM314TFB	30/300	5/400	310	11.2		
	LX110LPDP	11.03	300	349	1191	290	4.11	CSIR	MTRP0060-15	4TM758UFB	30/300		310	11.2		
	LA62LADM	6.23	188	219	746	141	5.30	RSCR	P330MD	4TM232TFB		4/400	310	10.9		
	LA72LADM	7.22	229	266	909	165	5.50	RSCR	P330MD	4TM265RFB		5/400	310	10.9		
LA80LADM	7.95	246	286	977	181	5.40	RSCR	P330MD	4TM293RFB		5/400	310	11.2			
LA86LADH	8.56	268	312	1064	197	5.40	CSR	P330MB	4TM314TFB	30/300	5/400	310	11.2			



M series & L series

Application

Middle & Large size refrigerator, freezer & Showcase

Specifications

R600a LBP 50Hz

Voltage/ Frequency	Model	Disp. (cc/rev)	PERFORMANCE					Motor Type	ELECTRICAL PARTS				Oil Charge (cc)	Net Weight (kg)	Development
			Ashrae			Consumption Power (w)	EER (Btu/wh)		Starting Device	Motor Protector	Capacitor				
			Capacity (-23.3°C)								Starting (MFD/VAC)	Running (MFD/VAC)			
			kcal/h	w	Btu/h										
220-240/50	MB62NAEG	6.24	116	134.4	459	72	6.33	RSIR	P330MC	4TM149NFB			220	8.9	
	MB62NAEM	6.24	116	134.4	459	69	6.63	RSCR	P330MD	4TM149NFB		3/400	220	8.9	
	MB82NAEG	8.15	161	187.5	640	98	6.50	RSIR	P330MC	4TM174TFB			220	9.4	
	MB82NAEM	8.15	161	187.5	640	98	6.88	RSCR	P330MD	4TM174TFB		4/400	220	9.4	
	MB98NAEM	8.15	161	187.5	640	98	6.88	RSCR	P330MD	4TM174TFB		4/400	220	9.4	
	MC62NAEM	6.24	122	141.5	483	69	6.98	RSCR	P330MD	4TM104RFB		4/400	220	8.9	
	MC98NAEM	9.83	204	237	572	111	7.26	RSCR	P330MD	4TM174TFB		5/400	220	9.4	

R134a HBP 50, 60Hz

Voltage/ Frequency	Model	Disp. (cc/rev)	PERFORMANCE					Motor Type	ELECTRICAL PARTS				Oil Charge (cc)	Net Weight (kg)	Development
			Ashrae			Consumption Power (w)	EER (Btu/wh)		Starting Device	Motor Protector	Capacitor				
			Capacity (-23.3°C)								Starting (MFD/VAC)	Running (MFD/VAC)			
			kcal/h	w	Btu/h										
220/60	LX72HPDG	7.22	695	808	2759	397	7.00	RSIR	P470MC	4TM412RFB			310	11.2	
	LX72HPDP	7.22	700	814	2779	385	7.20	CSIR	MTRP0058-15	4TM758UFB	30/300		310	11.2	
	LX86HPDP	8.56	840	977	3335	460	7.25	CSIR	MTRP0058-15	4TM758UFB	30/300		310	11.2	
	LX110HPDP	11.03	1000	1163	3970	630	6.30	CSIR	SC075	MRA12113-901	30/300		310	11.2	
	LX110HHDH	11.03	1000	860	3970	630	6.30	CSR	330MB3, QP2-33MB3	4TM762VFB	5/400	30/300	310	11.2	
	LX125HPDP	12.54	1200	1395	4764	760	6.27	CSIR	SC075	MRA12101	30/300		310	11.2	
110-115/60	LX86HAQG	8.56	319	371	1266	210	6.03	RSIR	P6R8MC	RA12057-9010			180	6.4	
	LX86HPQF	8.56	850	988	3375	450	7.50	RSIR	P6R8MC	4TM795VFB			310	11.2	
220-240/50	LX72HAEG	7.22	630	733	2501	325	7.70	RSIR	P470MC	4TM758UFB			310	11.2	
	LX72HAEP	7.22	600	698	2382	315	7.56	CSIR	MTRP0060-15	4TM758UFB	30/300		310	11.2	
	LX86HAEG	8.56	745	866	2958	385	7.68	RSIR	P470MC	4TM743UFB			310	11.2	
	LX86HAEP	8.56	710	826	2819	385	7.32	CSIR	MTRP0060-15	4TM758UFB	30/300		310	11.2	
	LX95HAEG	9.51	830	965	3295	440	7.49	RSIR	P470MC	4TM758UFB			310	11.2	
	LX110HAEM	11.03	950	1105	3772	503	7.50	RSCR	P470MD	4TM734UFB		4/400	310	11.2	
220/50-60	MA53HHBG	5.25	520	447.2	2064	285	7.24	RSIR	330MC, QP2-33MC	4TM276VFB			220	8.6	

Mountings

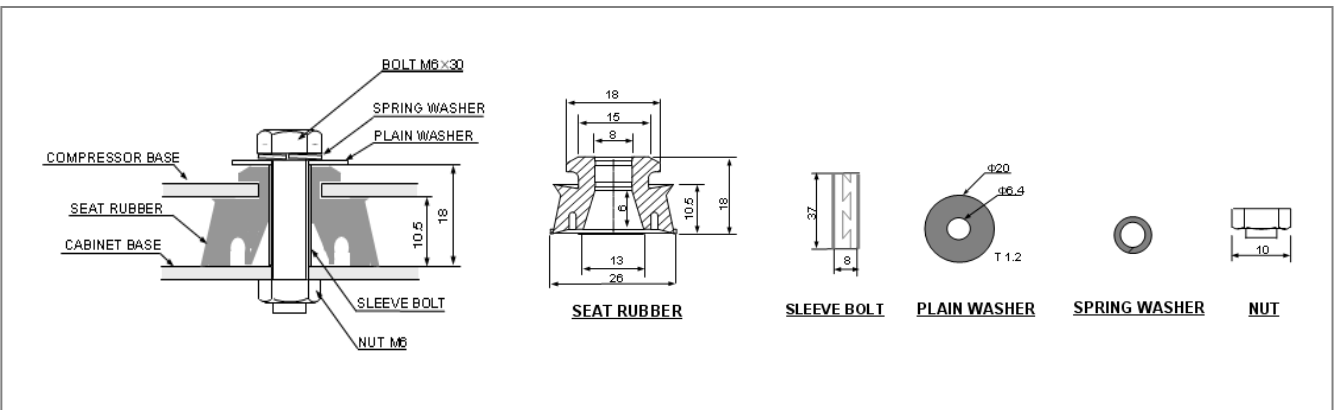

LG can accept no responsibility for possible errors in catalogues. LG reserves the right to alter its products without notice. This also applies to products already on order provided that such alterations can be made without sub sequential changes being necessary in specifications already agreed.6



M series & L series

Application

Middle & Large size refrigerator, freezer & Showcase

Compressor Dimension

(Unit : mm)

MA/MB/MC series

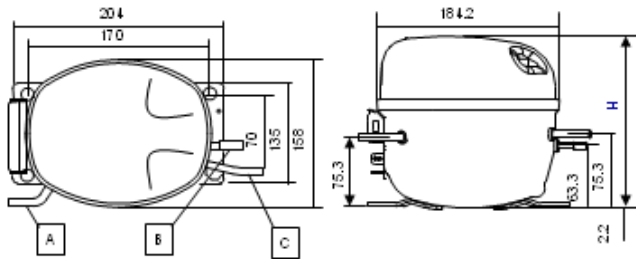

Series	H	A		B		C	
		SUCTION		DISCHARGE		PROCESS	
		ID	T	ID	T	ID	T
MA53	172	6.54	0.7	5.0	0.85	6.54	0.7
MB53/57							
MC53/57							
MA57/62/69/72	180	6.14	0.9	5.0	0.85	6.14	0.9
MB62/69							
MC62/69/98							
MB82/88/98	182	6.14	0.9	5.0	0.85	6.14	0.9
MC57/62/98							

LX / LA series

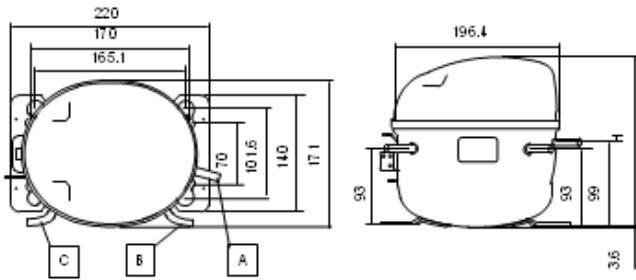

Series	H	A		B		C	
		SUCTION		DISCHARGE		PROCESS	
		ID	T	ID	T	ID	T
LX(A)62/67/72/86	200	6.54	0.7	5.0	0.85	6.54	0.7
LX86/95/110/125	203						
LA72/80/86/95	203						



Wiring Diagram

LGE Hermetic Compressor for Refrigeration

RSIR

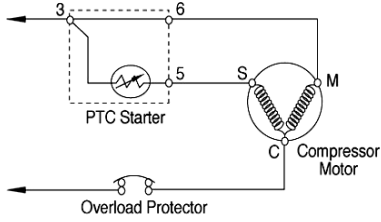
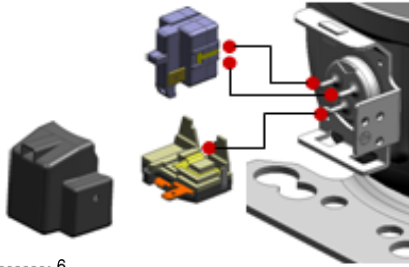

RSCR

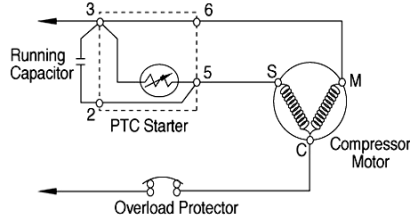
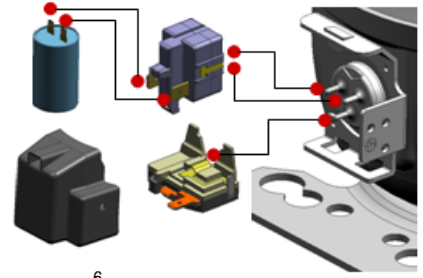

CSIR

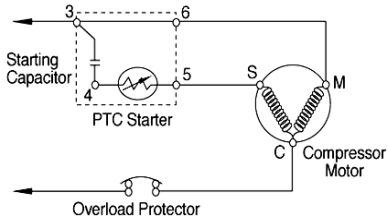
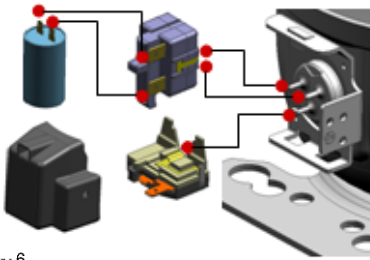

CSR

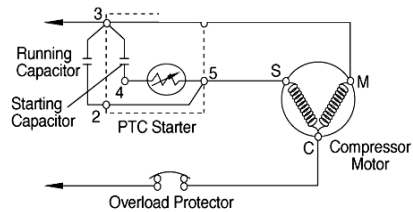
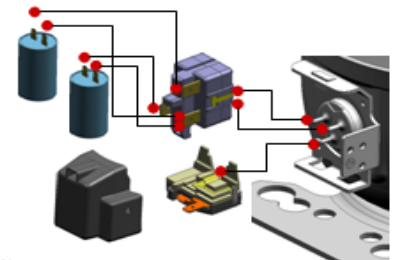

CSIR (Relay)

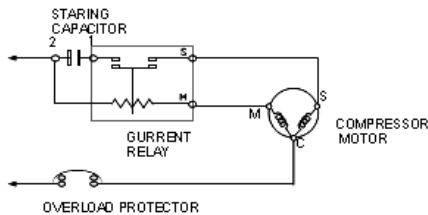
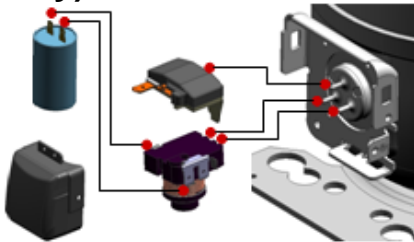

RSCR (Terminal Board)

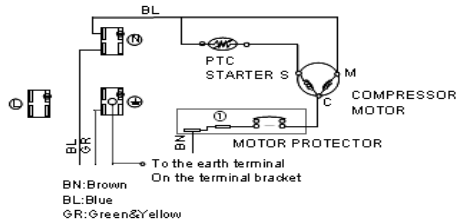
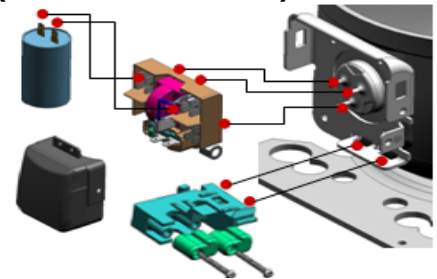



Packing Information

LGE Hermetic Compressor for Refrigeration

Carton dimension & Packing method

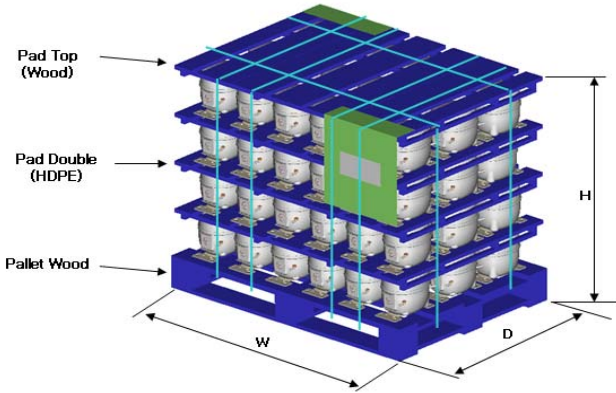

20ft Container

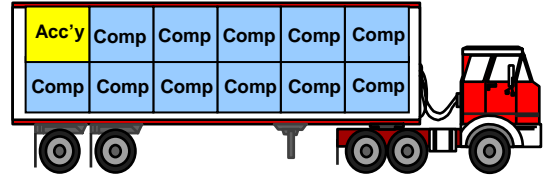

Model	Carton					Container (Below 15.3Ton)		Container (Below 17.5Ton)	
	Q'ty	Array	Dimension			Q'ty	CNTR	Q'ty	CNTR
	(EA)	(WxDxH)	W	D	H	(EA)	Weight(kg)	(EA)	Weight(kg)
TS24	150	(5X5X6)	1,100	800	1,046	2,700	15,540	3,000	17,200
TS24 (35mm)	125	(5X5X5)	1,100	800	1,046	2,375	15,088	2,750	17,375
NS24,NSA24,NSB24 NS30LAEG	125	(5X5X5)	1,100	800	950	2,375	15,325	2,750	17,650
NS30/36,NSA30/36 NSB30/36.NS24LB	125	(5X5X5)	1,100	800	1,000	2,125	15,050	2,500	17,600
NSA43,NSB43	125	(5X5X5)	1,100	800	1,015	2,000	15,200	2,250	17,025
SQ	125	(5X5X5)	1,100	800	1,060	2,000	15,400	2,250	17,250
MA53LADG	72	(3X6X4)	1,100	800	876	1,584	15,164	1,800	17,150
MA53LABM,LADM,LAUG,LCDG, MA57LAFM	72	(3X6X4)	1,100	800	876	1,512	15,258	1,728	17,352
MA53LACM,LCCM,LAAM MA57LABM,LACM.LADG.LAEG.LAQF	72	(3X6X4)	1,100	800	916	1,440	15,136	1,656	17,316
MB82NAEM,98NAAH,EM MA62LACH.CG.72PDP	72	(3X6X4)	1,100	800	916	1,440	15,424	1,656	17,648
MB53LADM,MB57LADM	72	(3X6X4)	1,100	800	916	1,368	15,093	1,584	17,382
MQ,MF, MQV	72	(3X6X4)	1,100	800	916	1,368	15,504	1,584	17,857
LX67/72, LX67/72	64	(4X4X4)	1,100	800	997	1,280	15,552	1,408	17,047
LX86/95/110/125	64	(4X4X4)	1,100	800	1,012	1,216	15,169	1,408	17,470
LA62/72/80/95	64	(4X4X4)	1,100	800	1,012	1,216	14,926	1,408	17,188
LQ,LF	64	(4X4X4)	1,100	800	1,024	1,216	15,412	1,408	17,751
FC	60	(3X5X4)	1,100	800	1,030	1,200	13,380	1,200	13,380
FM	64	(4X4X4)	1,100	800	1,030	1,280	11,460	1,280	11,460



Application

LGE Hermetic Compressor for Refrigeration

Appli.	Ambient Temperature	Evaporating Temperature	Condensing Temperature	Sub cooled Liquid Temp Expansion Device	Suction Gas Temperature	Suction Pressure				Discharge Pressure			
						R134a		R600a		R134a		R600a	
						kg/cm ² (g)	Psi(g)	kg/cm ² (g)	Psi(g)	kg/cm ² (g)	Psi(g)	kg/cm ² (g)	Psi(g)
LBP	32	-23.3	54.4	32	32	0.14	1.99	-0.389	-5.53	13.96	198.55	6.726	95.66
HBP	35	7.2	54.4	32	35	2.82	40.1	-	-	13.96	198.55	-	-

Evaporating Temperature Range	
LBP	-30 to -5°C
HBP	-5 to +15°C

* Envelope is only for LBP application.

A : Stabilized Condition
B : Transition Running
C : Peak Condition

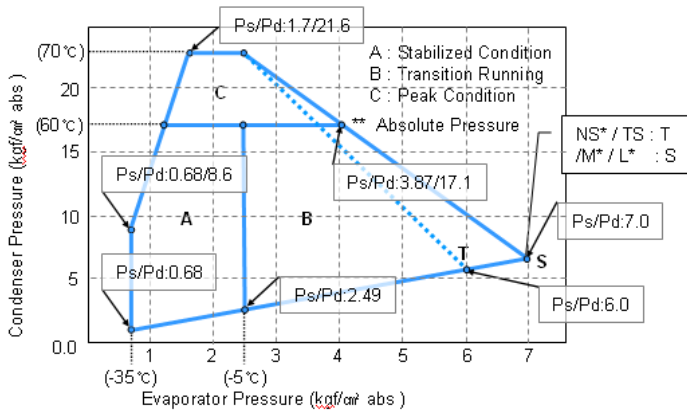

R134a

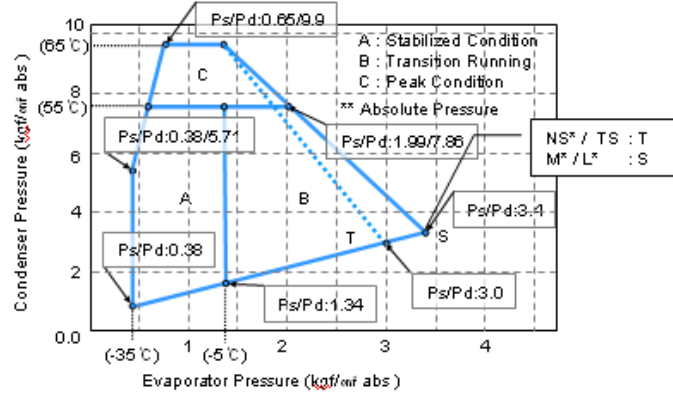

R600a

Safety

WARNING



Install the refrigerant, lubricant oil and electrical component (Capacitor and Controller) specified by compressor manufacturer.
It can cause fire or electrical shock.



Connect the electrical wiring correctly in accordance with manufacturer's instruction.
It can cause fire or electrical shock.



Compressor must be grounded whenever power is supplied.
It can cause electrical shock.



Before servicing, always remove the power plug from the outlet.
It can cause electrical shock.



Before welding, always remove refrigerant in the compressor.
Do not operate compressor in the air or vacuum status.
It can cause explosion.



Do not touch the compressor with bare hands during operation or after stopping instantly.
It can cause get burnt.



Compressor Designation

LGE Hermetic Compressor for Refrigeration

Compressor name code

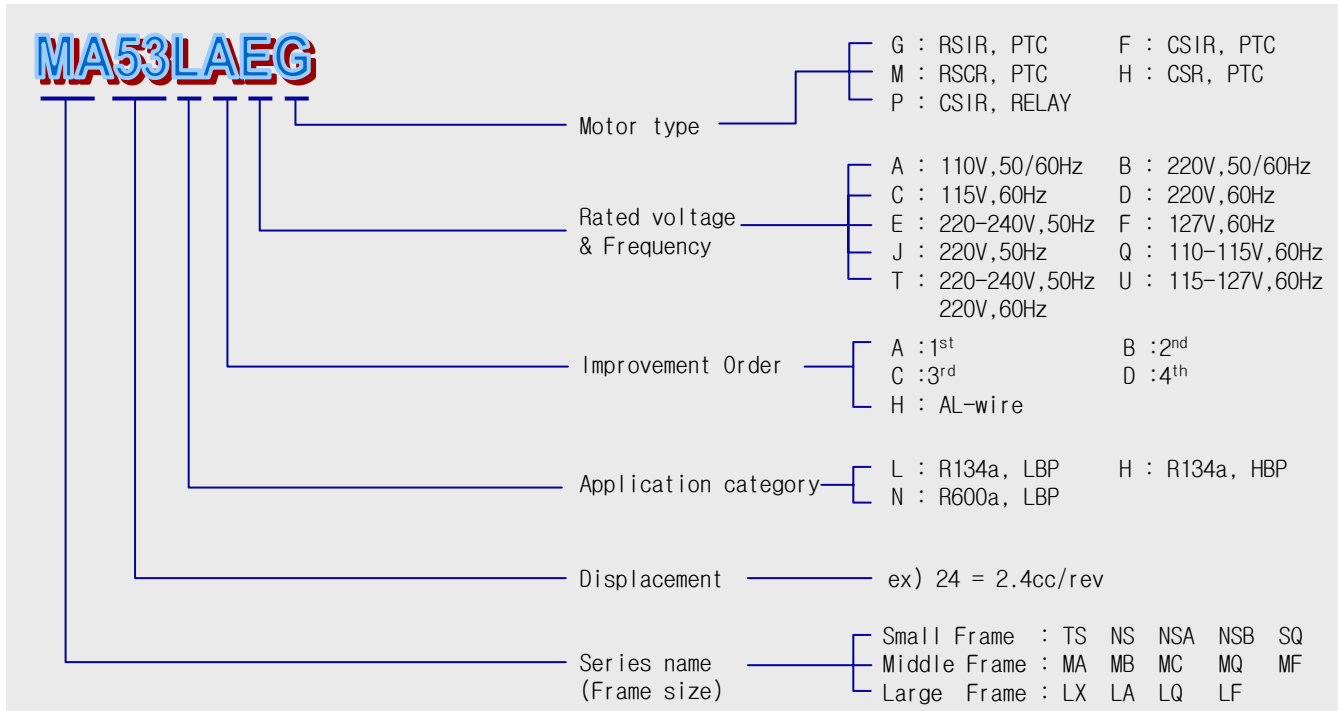

Serial number

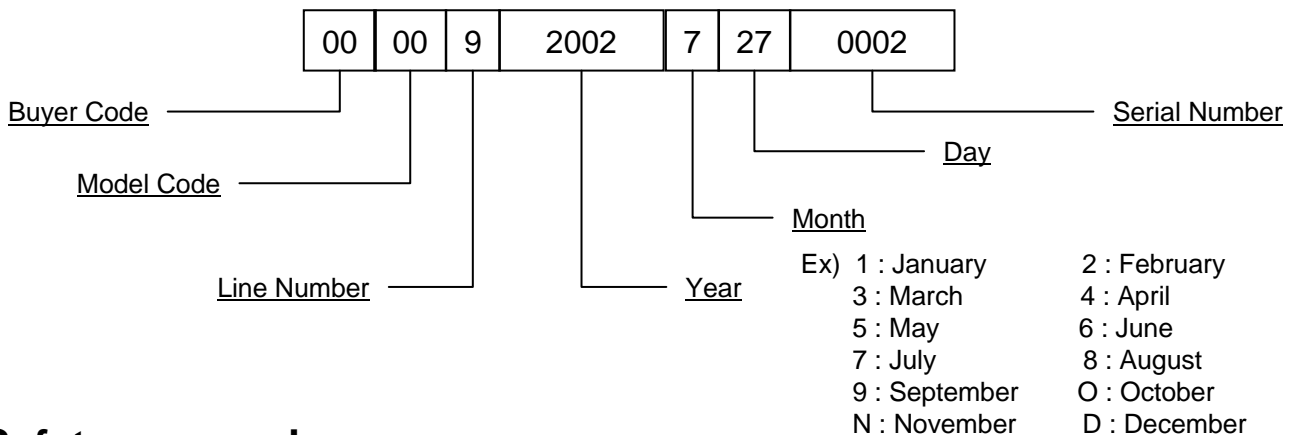

Safety approval

VDE approved model	UL approved model	CSA approved model	CCC approved model

SA6269 LR41087 B370019

LG Refrigeration Compressor

SQ



Compressor & Motor Division



LG Electronics / Home Appliance Company

※ The numerical values shown in this material have been obtained based on current model.
They might be changed or modified by mutual agreement with customer in the future



SQ series

Application

Refrigerator, freezer & water dispenser

Specifications

R134a **LBP** **60Hz**

Voltage/ Frequency	Model	Disp. (cc/rev)	PERFORMANCE					Motor Type	ELECTRICAL PARTS				Oil Charge (cc)	Net Weight (kg)
			60Hz Ashrae						Starting Device	Motor Protector	Capacitor			
			Capacity (-23.3°C)			Consumption Power (w)	EER (Btu/wh)				Starting (MFD/VAC)	Running (MFD/VAC)		
			kcal/h	w	Btu/h									
110-115/60	SQ53LAQG	5.3	146	170	580	141	4.10	RSIR	6R8MC1	4TM412RFB	-	-	180	6.9
220/60	SQ43LADG	4.3	110	128	437	128	3.40	RSIR	220MC1	4TM205RFB	-	-	180	6.9
	SQ47LDDG	4.7	126	147	500	130	3.85	RSIR	220MC1	4TM174TFB	-	-	180	6.9
	SQ47LADM	4.7	126	147	500	111	4.50	RSCR	330MD2	4TM166WHB		4/400	180	6.9
	SQ47LBDM	4.7	126	147	500	105	4.75	RSCR	220MD2	4TM166RFB	-	4/400	180	6.9
	SQ53LADG	5.3	146	170	580	135	4.30	RSIR	330MC1	4TM205RFB		-	180	6.9

R134a **LBP** **50Hz**

Voltage/ Frequency	Model	Disp. (cc/rev)	PERFORMANCE					Motor Type	ELECTRICAL PARTS				Oil Charge (cc)	Net Weight (kg)
			50Hz Ashrae						Starting Device	Motor Protector	Capacitor			
			Capacity (-23.3°C)			Consumption Power (w)	EER (Btu/wh)				Starting (MFD/VAC)	Running (MFD/VAC)		
			kcal/h	w	Btu/h									
220/50	SQ43LHJG	4.3	94	109	373	107	3.50	RSIR	330MC1	4TM166RFB	-	-	180	6.9
	SQ47LBJG	4.7	107	124	425	121	3.50	RSIR	220MC1	4TM213SFB	-	-	180	6.9
	SQ53LBJG	5.3	124	144	492	133	3.70	RSIR	220MC1	4TM213SFB	-	-	180	6.9
	SQ57LBJG	5.7	135	157	536	131	4.10	RSIR	330MC1	4TM174TFB	-	-	180	6.9
220-240/50	SQ47LAEG	4.7	107	124	425	97	4.40	RSIR	330MC1	4TM166RFB	-	-	180	6.9

R12 **LBP** **50Hz**

Voltage/ Frequency	Model	Disp. (cc/rev)	PERFORMANCE					Motor Type	ELECTRICAL PARTS				Oil Charge (cc)	Net Weight (kg)
			50Hz Ashrae						Starting Device	Motor Protector	Capacitor			
			Capacity (-23.3°C)			Consumption Power (w)	EER (Btu/wh)				Starting (MFD/VAC)	Running (MFD/VAC)		
			kcal/h	w	Btu/h									
220/50	SQ53BJG	5.3	137	159	544	140	3.90	RSIR	220MC1	4TM213SFB			180	6.9
	SQ57BJG	5.7	153	178	607	145	4.20	RSIR	330MC1	4TM174TFB			180	6.9



SQ series

Application
Refrigerator, freezer & water dispenser

Compressor Dimension

(Unit : mm)

SQ series

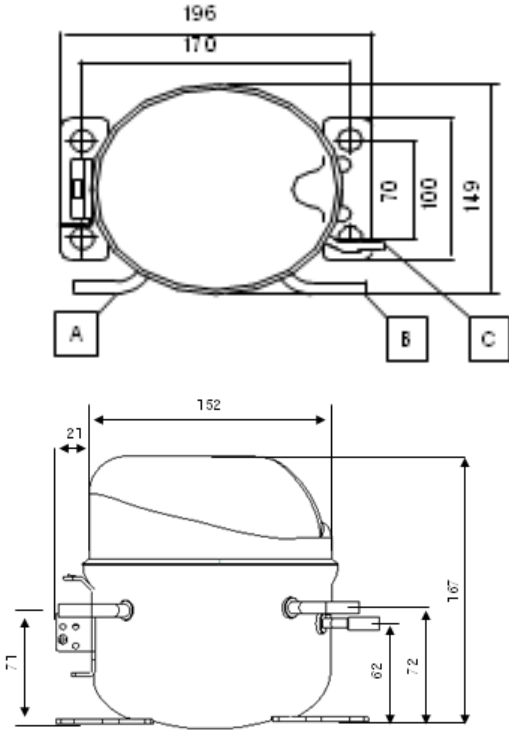

A		B		C	
SUCTION		PROCESS		DISCHARGE	
ID	T	ID	T	ID	T
6.54	0.7	6.54	0.7	5.0	0.85
6.14	0.9	6.14	0.9		

Mountings

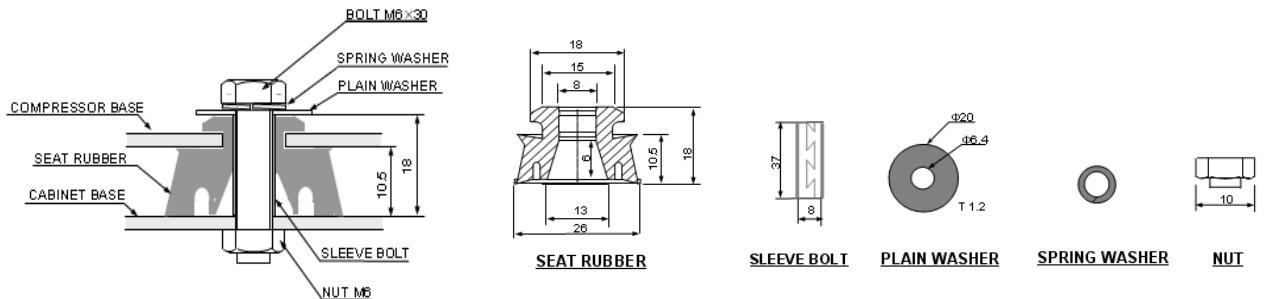



Wiring Diagram

LGE Hermetic Compressor for Refrigeration

RSIR

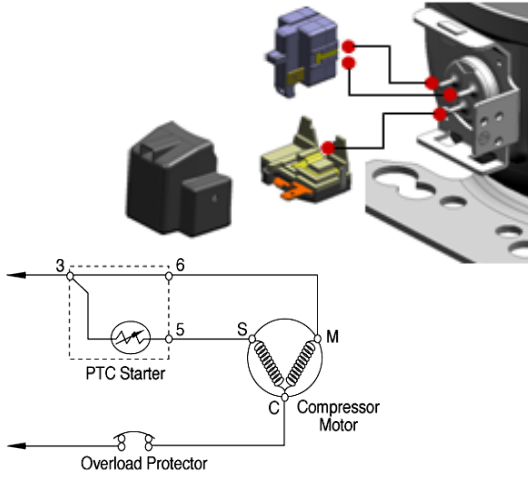

RSCR

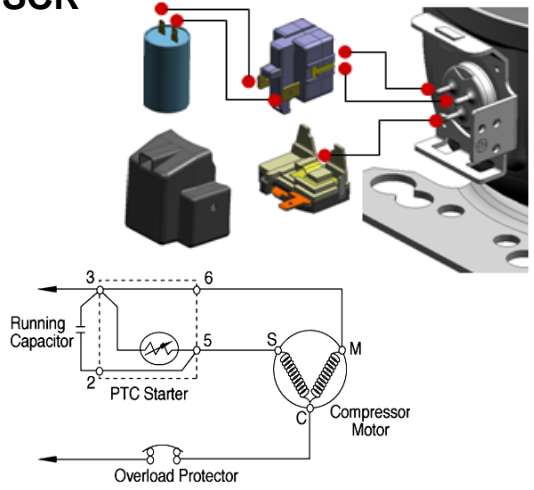

CSIR

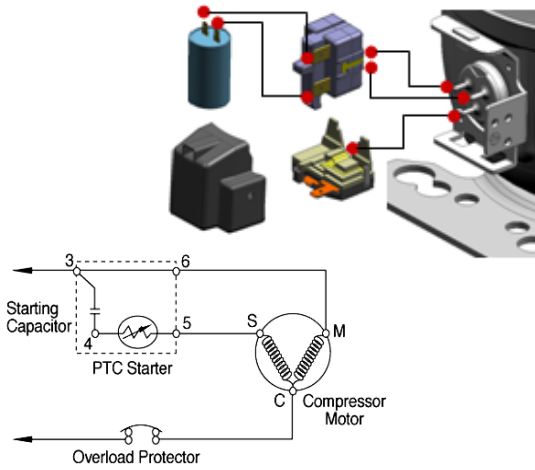

CSR

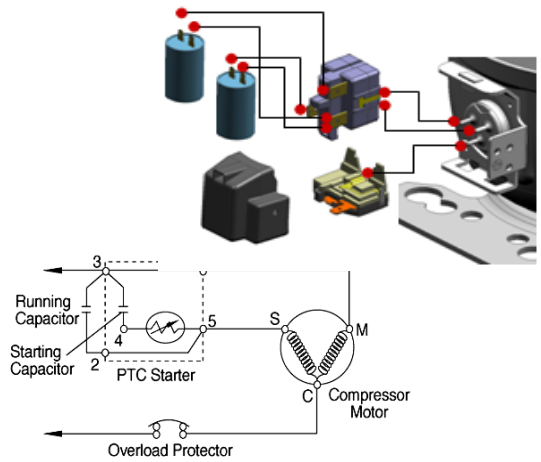



Packing Information

LGE Hermetic Compressor for Refrigeration

Carton dimension & Packing method

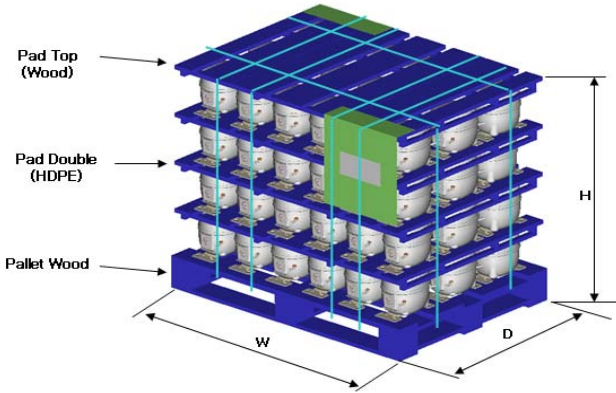

20ft Container

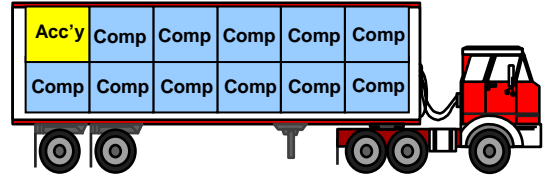

Model	Carton					Container (Below 15.3Ton)		Container (Below 17.5Ton)	
	Q'ty	Array	Dimension			Q'ty	CNTR	Q'ty	CNTR
	(EA)	(WxDxH)	W	D	H	(EA)	Weight(kg)	(EA)	Weight(kg)
TS24	150	(5X5X6)	1,100	800	1,046	2,700	15,540	3,000	17,200
TS24 (35mm)	125	(5X5X5)	1,100	800	1,046	2,375	15,088	2,750	17,375
NS24,NSA24,NSB24 NS30LAEG	125	(5X5X5)	1,100	800	950	2,375	15,325	2,750	17,650
NS30/36,NSA30/36 NSB30/36.NS24LB	125	(5X5X5)	1,100	800	1,000	2,125	15,050	2,500	17,600
NSA43,NSB43	125	(5X5X5)	1,100	800	1,015	2,000	15,200	2,250	17,025
SQ	125	(5X5X5)	1,100	800	1,060	2,000	15,400	2,250	17,250
MA53LADG	72	(3X6X4)	1,100	800	876	1,584	15,164	1,800	17,150
MA53LABM,LADM,LAUG,LCDG, MA57LAFM	72	(3X6X4)	1,100	800	876	1,512	15,258	1,728	17,352
MA53LACM,LCCM,LAAM MA57LABM,LACM,LADG,LAEG,LAQF	72	(3X6X4)	1,100	800	916	1,440	15,136	1,656	17,316
MB82NAEM,98NAAH,EM MA62LACH.CG.72PDP	72	(3X6X4)	1,100	800	916	1,440	15,424	1,656	17,648
MB53LADM,MB57LADM	72	(3X6X4)	1,100	800	916	1,368	15,093	1,584	17,382
MQ,MF, MQV	72	(3X6X4)	1,100	800	916	1,368	15,504	1,584	17,857
LX67/72, LX67/72	64	(4X4X4)	1,100	800	997	1,280	15,552	1,408	17,047
LX86/95/110/125	64	(4X4X4)	1,100	800	1,012	1,216	15,169	1,408	17,470
LA62/72/80/95	64	(4X4X4)	1,100	800	1,012	1,216	14,926	1,408	17,188
LQ,LF	64	(4X4X4)	1,100	800	1,024	1,216	15,412	1,408	17,751
FC	60	(3X5X4)	1,100	800	1,030	1,200	13,380	1,200	13,380
FM	64	(4X4X4)	1,100	800	1,030	1,280	11,460	1,280	11,460



Application

LGE Hermetic Compressor for Refrigeration

Appli.	Ambient Temperature	Evaporating Temperature	Condensing Temperature	Sub cooled Liquid Temp Expansion Device	Suction Gas Temperature	Suction Pressure				Discharge Pressure			
						R134a		R600a		R134a		R600a	
						kg/cm ² (g)	Psi(g)	kg/cm ² (g)	Psi(g)	kg/cm ² (g)	Psi(g)	kg/cm ² (g)	Psi(g)
LBP	32	-23.3	54.4	32	32	0.14	1.99	-0.389	-5.53	13.96	198.55	6.726	95.66
HBP	35	7.2	54.4	32	35	2.82	40.1	-	-	13.96	198.55	-	-

Evaporating Temperature Range	
LBP	-30 to -5°C
HBP	-5 to +15°C

* Envelope is only for LBP application.

A : Stabilized Condition
B : Transition Running
C : Peak Condition

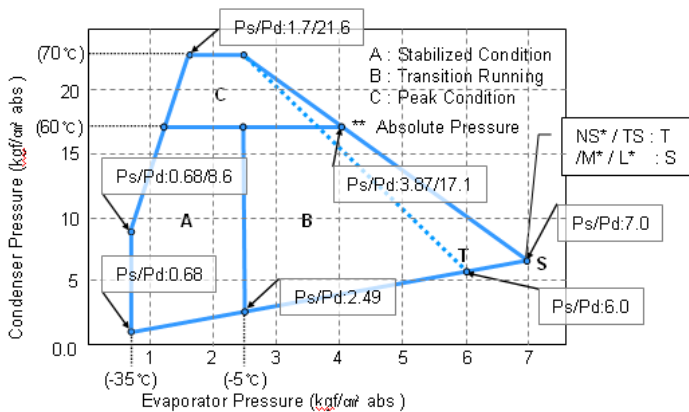

R134a

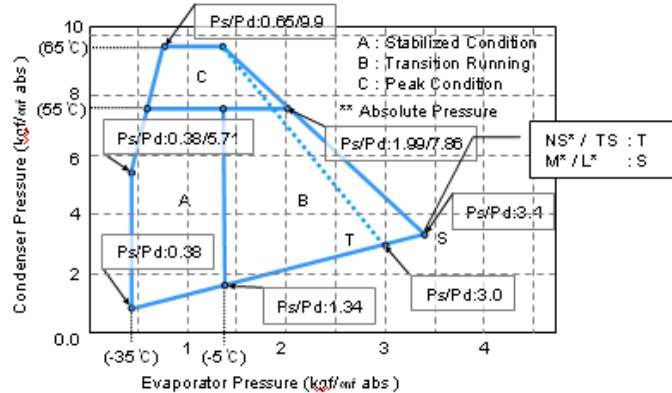

R600a

Safety

⚠ WARNING



Install the refrigerant, lubricant oil and electrical component (Capacitor and Controller) specified by compressor manufacturer.
It can cause fire or electrical shock.



Connect the electrical wiring correctly in accordance with manufacturer's instruction.
It can cause fire or electrical shock.



Compressor must be grounded whenever power is supplied.
It can cause electrical shock.



Before servicing, always remove the power plug from the outlet.
It can cause electrical shock.



Before welding, always remove refrigerant in the compressor. Do not operate compressor in the air or vacuum status.
It can cause explosion.



Do not touch the compressor with bare hands during operation or after stopping instantly.
It can cause get burnt.



Compressor Designation

LGE Hermetic Compressor for Refrigeration

Compressor name code

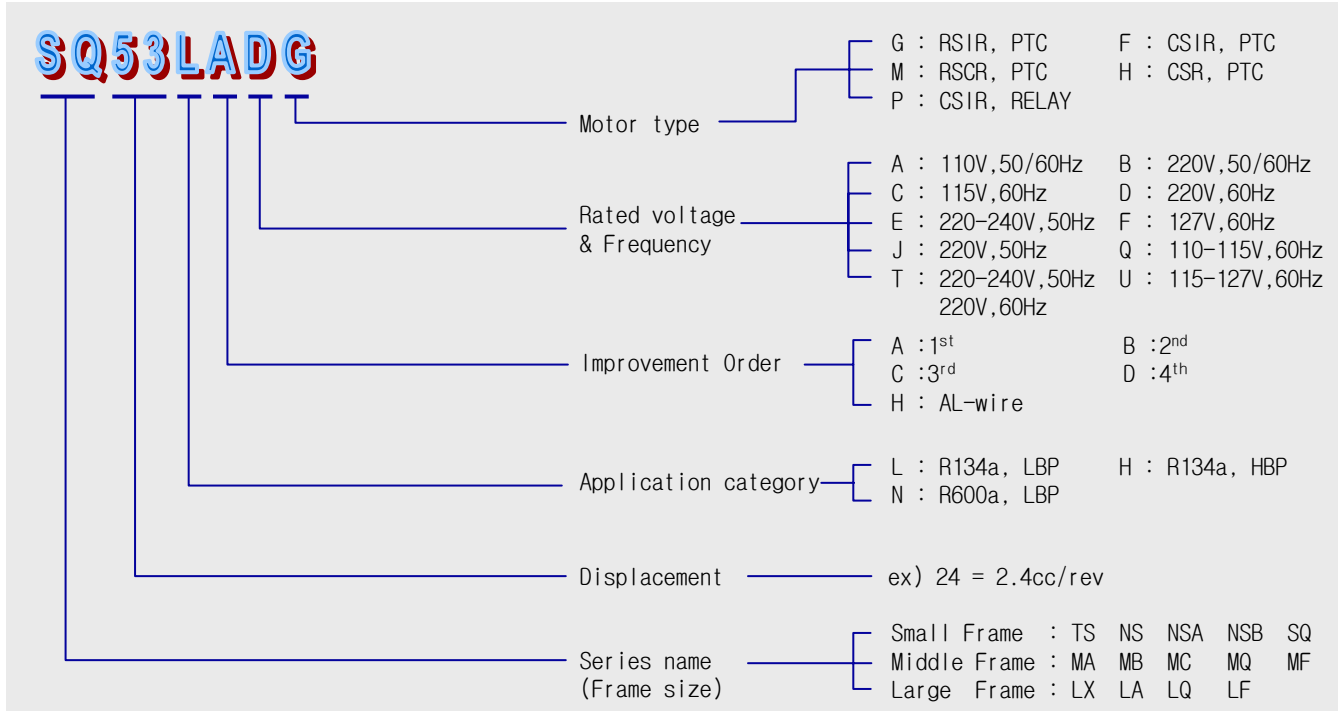

Serial number

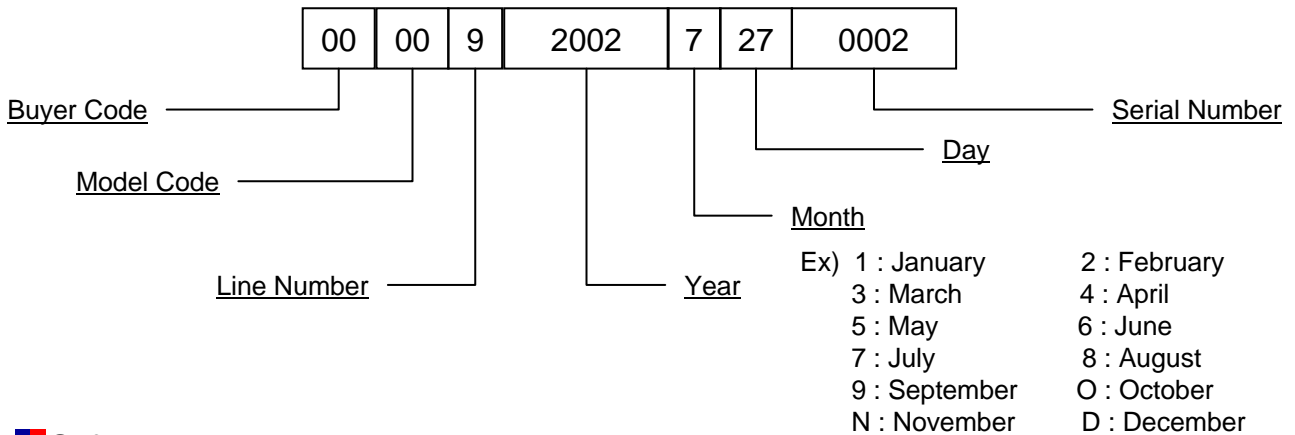

Safety approval

				
VDE approved model	UL approved model	SA6269	LR41087	B370019
				TIS.812-2548
CSA approved model CCC approved model TIS approved model				

LG Refrigeration Compressor

BLDC

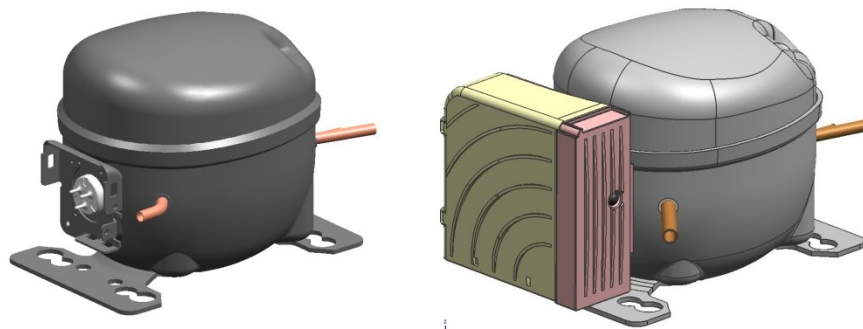

Compressor & Motor Division



LG Electronics / Home Appliance Company

The numerical values shown in this material have been obtained based on current model.
They might be changed or modified by mutual agreement with customer in the future



BLDC

Application

Middle & Large size refrigerator, freezer & Showcase



Specifications

R134a LBP

Model	Voltage [V]	Freq. [Hz]	Operating condition								
			Te/Tc = -23.3/40.6 , RT32.2				ASHRAE				
			CCR [%]	Capacity [W]	EER [Btu/Whr]	COP [W/W]	CCR [%]	Capacity [Btu/Whr]	EER [Btu/Whr]	COP [W/W]	
MQ69 LAMV	220~240	75	125%	331			125%	1041			
		60	100%	265	7.10	2.08	100%	833	6.00	1.76	
		42	70%	193	7.40	2.17	70%	606	6.25	1.83	
		30	50%	140	7.50	2.20	50%	438	6.37	1.87	
MQ53 LAMV	220~240	28	47%	130	7.45	2.18	45%	409	6.32	1.85	
		75	125%	255			125%	800			
		60	100%	204	7.00	2.05	100%	640	5.90	1.73	
		42	70%	148	7.30	2.14	70%	466	6.15	1.80	
BMA053 LAMV	220~240	30	50%	107	7.40	2.17	50%	337	6.27	1.84	
		27	45%	100	7.35	2.15	45%	314	6.22	1.82	
		75	125%	255			125%	800			
		60	100%	204	7.30	2.14	100%	640	5.70	1.67	
BMA069 LAMV	220~240	30	50%	148	7.80	2.29	50%	466	6.20	1.82	
		25	42%	107	7.90	2.32	42%	337	6.30	1.85	
		20	33%	100	7.85	2.30	33%	314	6.25	1.83	
		75	125%	331			125%	1041			
BMA082 LAMV	220~240	60	100%	265	7.40	2.17	100%	833	5.80	1.70	
		30	50%	193	7.90	2.32	50%	606	6.30	1.85	
		25	42%	140	8.00	2.34	42%	438	6.40	1.88	
		20	33%	130	7.95	2.33	33%	409	6.35	1.86	
BMA082 LAMV	220~240	75	125%	394			125%	1237			
		60	100%	315	7.35	2.15	100%	990	5.75	1.69	
		30	50%	229	7.85	2.30	50%	721	6.25	1.83	
		25	42%	166	7.95	2.33	42%	521	6.35	1.86	
BMA082 LAMV	220~240	20	33%	155	7.90	2.32	33%	486	6.30	1.85	
		Remark		Experiment				Experiment			

R600a LBP

Model	Voltage [V]	Freq. [Hz]	Operating condition							
			Te/Tc = -25/35 , RT32.2				ASHRAE			
			CCR [%]	Capacity [W]	EER [Btu/Whr]	COP [W/W]	CCR [%]	Capacity [Btu/Whr]	EER [Btu/Whr]	COP [W/W]
MQ108 NBMV	220~240	72	96%	282			96%	941		
		60	80%	235	7.00	2.05	80%	810	6.00	1.76
		42	56%	165	7.50	2.20	56%	592	6.31	1.85
		30	40%	118	7.60	2.23	40%	429	6.40	1.88
BMA108 NAMV	220~240	28	37%	110	7.53	2.21	37%	400	6.34	1.86
		75	100%	217			100%	980		
		60	80%	181	7.15	2.10	80%	810	6.60	1.93
		30	40%	127	8.15	2.39	40%	429	6.96	2.04
BMA098 NAMV	220~240	25	33%	90	8.25	2.42	33%	357	7.05	2.07
		20	27%	84	8.17	2.39	27%	286	6.98	2.05
		75	100%	267			100%	889		
		60	80%	214	7.15	2.10	80%	735	6.60	1.93
BMA098 NHMV	220~240	30	40%	107	8.15	2.39	40%	389	6.96	2.04
		25	33%	89	8.25	2.42	33%	324	7.05	2.07
		20	27%	71	8.17	2.39	27%	259	6.98	2.05
		75	100%	267			100%	889		
BMA098 NHMV	220~240	60	80%	214	7.20	2.11	80%	735	6.20	1.82
		30	40%	107	7.70	2.26	40%	389	6.56	1.92
		25	33%	89	7.80	2.29	33%	324	6.65	1.95
		20	27%	71	7.72	2.26	27%	259	6.58	1.93
Remark		Simulation				Simulation				

Dual Frequency Performance Criteria : 60Hz

(Fan on 1.8m/s)

LG can accept no responsibility for possible errors in catalogues. LG reserves the right to alter its products without notice. This also applies to products already on order provided that such alterations can be made without sub sequential changes being necessary in specifications already agreed.6



BLDC

Application
Middle & Large size refrigerator, freezer & Showcase

Compressor Dimension

(Unit : mm)

MQ (Compressor)

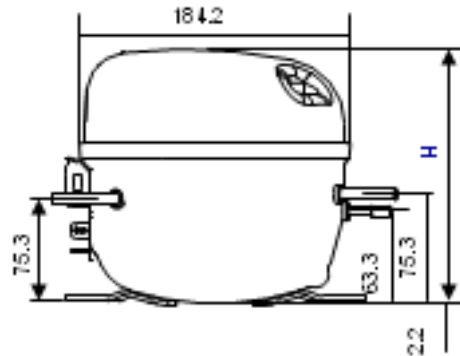
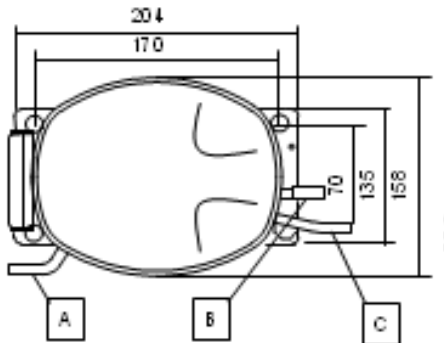

MQ (compressor + Controller)

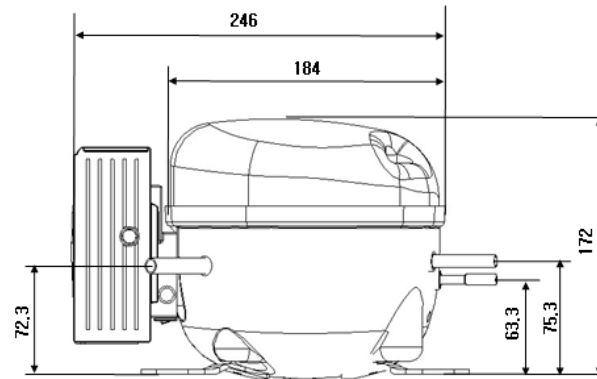
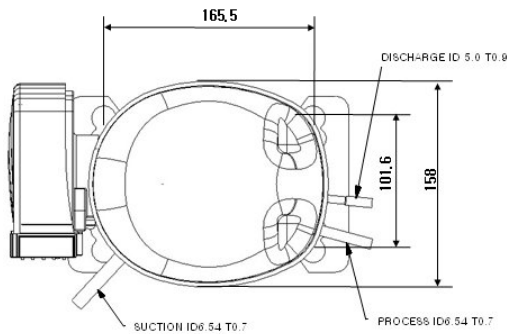

Series	H	A		B		C	
		SUCTION		DISCHARGE		PROCESS	
		ID	T	ID	T	ID	T
MQV	172	6.14	0.7	5.0	0.85	6.14	0.7
		6.54	0.9			6.54	0.9



Packing Information

LGE Hermetic Compressor for Refrigeration

Carton dimension & Packing method

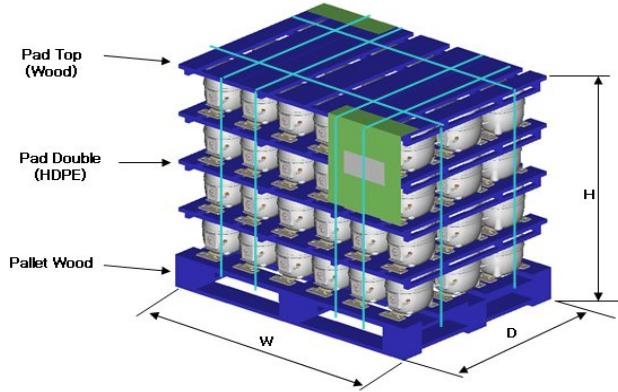

20ft Container

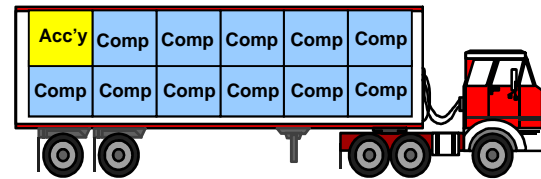

Model	Carton					Container (Below 15.3Ton)		Container (Below 17.5Ton)	
	Q'ty	Array	Dimension			Q'ty	CNTR	Q'ty	CNTR
	(EA)	(WxDxH)	W	D	H	(EA)	Weight(kg)	(EA)	Weight(kg)
TS24	150	(5X5X6)	1,100	800	1,046	2,700	15,540	3,000	17,200
TS24 (35mm)	125	(5X5X5)	1,100	800	1,046	2,375	15,088	2,750	17,375
NS24,NSA24,NSB24 NS30LAEG	125	(5X5X5)	1,100	800	950	2,375	15,325	2,750	17,650
NS30/36,NSA30/36 NSB30/36,NS24LB	125	(5X5X5)	1,100	800	1,000	2,125	15,050	2,500	17,600
NSA43,NSB43	125	(5X5X5)	1,100	800	1,015	2,000	15,200	2,250	17,025
SQ	125	(5X5X5)	1,100	800	1,060	2,000	15,400	2,250	17,250
MA53LADG	72	(3X6X4)	1,100	800	876	1,584	15,164	1,800	17,150
MA53LABM,LADM,LAUG,LCDG, MA57LAFM	72	(3X6X4)	1,100	800	876	1,512	15,258	1,728	17,352
MA53LACM,LCCM,LAAM MA57LABM,LACM,LADG,LAEG,LAQF	72	(3X6X4)	1,100	800	916	1,440	15,136	1,656	17,316
MB82NAEM,98NAAH,EM MA62LACH,CG,72PDP	72	(3X6X4)	1,100	800	916	1,440	15,424	1,656	17,648
MB53LADM,MB57LADM	72	(3X6X4)	1,100	800	916	1,368	15,093	1,584	17,382
MQ,MF, MQV	72	(3X6X4)	1,100	800	916	1,368	15,504	1,584	17,857
LX67/72, LX67/72	64	(4X4X4)	1,100	800	997	1,280	15,552	1,408	17,047
LX86/95/110/125	64	(4X4X4)	1,100	800	1,012	1,216	15,169	1,408	17,470
LA62/72/80/95	64	(4X4X4)	1,100	800	1,012	1,216	14,926	1,408	17,188
LQ,LF	64	(4X4X4)	1,100	800	1,024	1,216	15,412	1,408	17,751
FC	60	(3X5X4)	1,100	800	1,030	1,200	13,380	1,200	13,380
FM	64	(4X4X4)	1,100	800	1,030	1,280	11,460	1,280	11,460



Application

LGE Hermetic Compressor for Refrigeration

Appli.	Ambient Temperature	Evaporating Temperature	Condensing Temperature	Sub cooled Liquid Temp Expansion Device	Suction Gas Temperature	Suction Pressure				Discharge Pressure			
						R134a		R600a		R134a		R600a	
						kg/cm ² (g)	Psi(g)	kg/cm ² (g)	Psi(g)	kg/cm ² (g)	Psi(g)	kg/cm ² (g)	Psi(g)
LBP	32	-23.3	54.4	32	32	0.14	1.99	-0.389	-5.53	13.96	198.55	6.726	95.66

Evaporating Temperature Range	
LBP	-30 to -5

Envelope is only for LBP application.

A : Stabilized Condition
 B : Transition Running
 C : Peak Condition

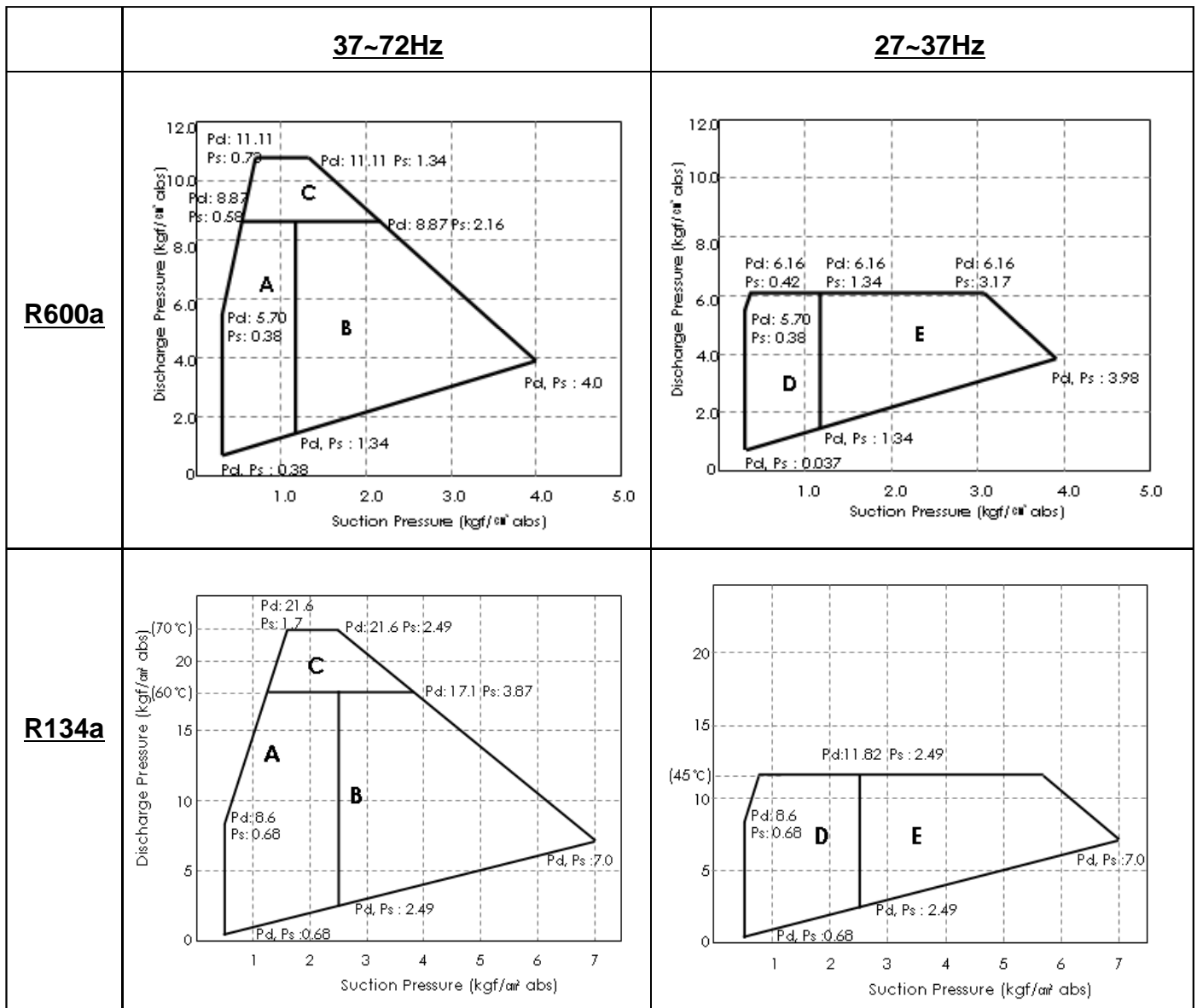



Compressor Designation

LGE Hermetic Compressor for Refrigeration

Compressor name code

MQ108NBMV

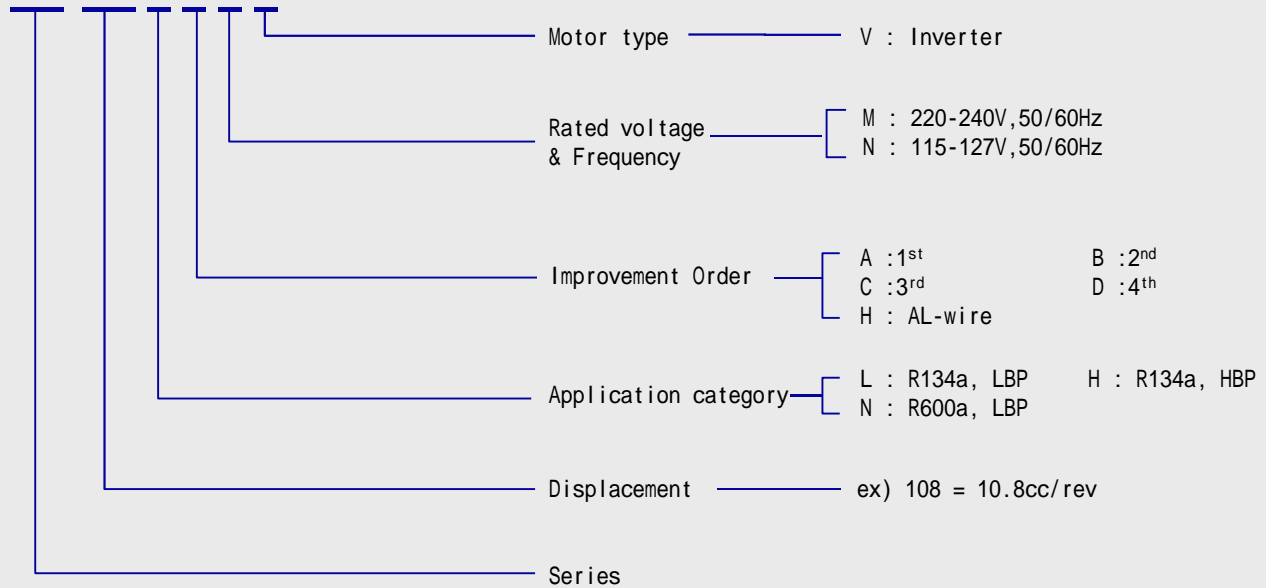

Serial number

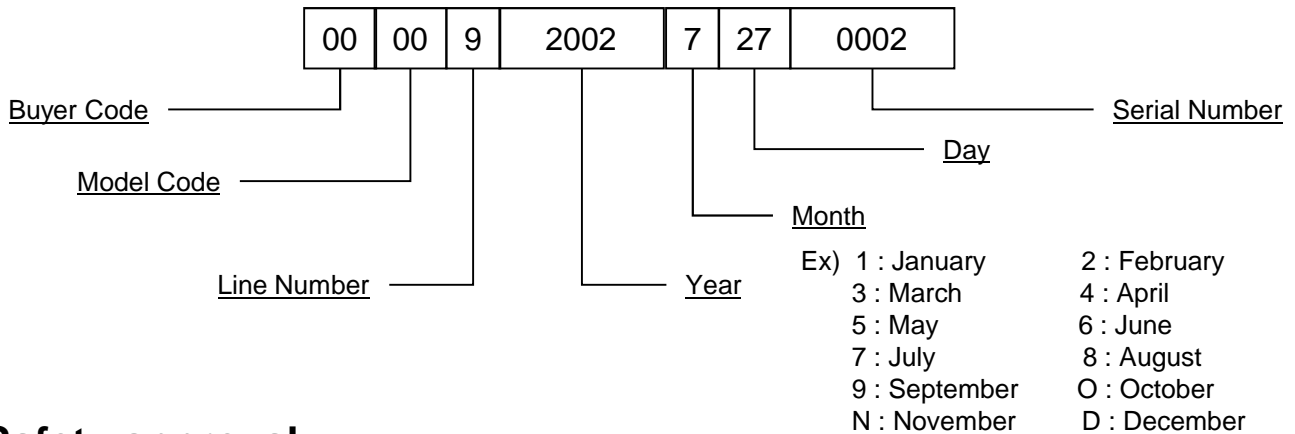

Safety approval



VDE approved model



UL approved model



CSA approved model



CCC approved model



Safety

LGE Hermetic Compressor for Refrigeration

WARNING



Install the refrigerant, lubricant oil and electrical component (Capacitor and Controller) specified by compressor manufacturer.

It can cause fire or electrical shock.



Connect the electrical wiring correctly in accordance with manufacturer's instruction.

It can cause fire or electrical shock.



Compressor must be grounded whenever power is supplied.

It can cause electrical shock.



Before servicing, always remove the power plug from the outlet.

It can cause electrical shock.



Before welding, always remove refrigerant in the compressor.

Do not operate compressor in the air or vacuum status.

It can cause explosion.



Do not touch the compressor with bare hands during operation or after stopping instantly.

It can cause get burnt.



How to Connect

LGE Hermetic Compressor for Refrigeration

Part of driver

Connection pipe of compressor

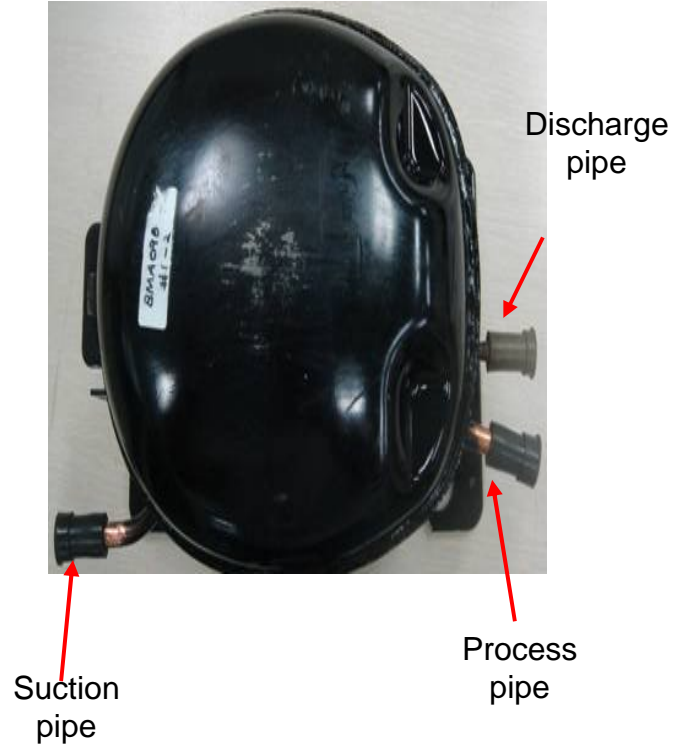
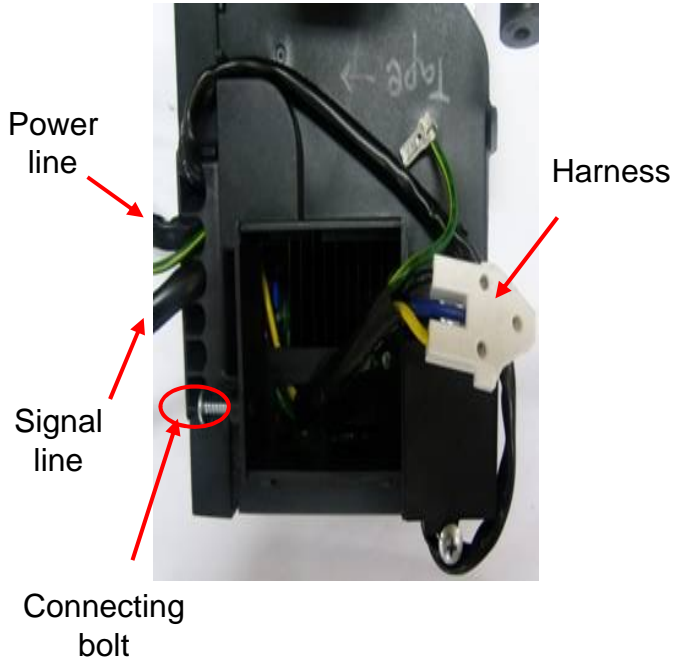

Connection of drive and compressor

